

4/2- and 4/3-directional spool valve Hydraulically operated 4WH 16

DESCRIPTION

The valves in nominal size 16 of the 4WH series are directional spool valves with hydraulic operation. They are used to control the start, stop and direction of the volume flow.

A wide variety of piston types and options for opening control are available in the context of the valve series.

FEATURES

- Hydraulically operated directional spool valve
- Electro-hydraulic operation via pilot valve NG 6 or hydraulic operation via interconnecting plate
- Flow rates up to 300 l/min
- The pilot supply and/or drain can be internal or external and can be achieved by changing the plug
- Interface according to ISO 4401-07



Nominal size 16
up to 300 l/min
up to 350 bar

CONTENTS

Description	1
Features	1
Model code	2
Spool types / symbols	2
Function	3
Section view	3
Technical data	4
Performance	4
Dimensions	5
Accessories	7

MODEL CODE

4WH E 16 G S01 /V /G

Type

4/2- or 4/3-directional spool valve, hydraulically operated

Control type

- E = external pilot drain and supply
- EI = external pilot supply, internal pilot drain
- I = internal pilot supply and drain (symbol G and H only with option G)
- IE = internal pilot supply, external pilot drain (symbol G and H only with option G)

Nominal size

16

Spool symbol ¹⁾

See page 2

Series

S01 = ISO 4401-07-07-0-05 (CETOP 4.2-4-07-320)

Sealing material

- N = NBR
- V = FKM (standard)

Options

- Not specified = without interconnecting plate (standard)
- G = with check valve (5 bar)
- UPA = with interconnecting plate P-A; B-T
- UPB = with interconnecting plate P-B; A-T

¹⁾ Other models on request

SPOOL TYPES / SYMBOLS

4/2-DIRECTIONAL SPOOL VALVES

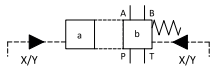

Type	Basic symbol	With intermediate position
C		
D		
Y		

For valves with electrical operation see brochure 5.227.10 "4WEH 4/2 and 4/3 way spool valves in nominal size 10 to 32".

4/3-DIRECTIONAL SPOOL VALVES

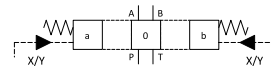

Type	Basic symbol	With intermediate position
E		
J		
H		
G		
Q		
L		

Interconnecting plate PATB

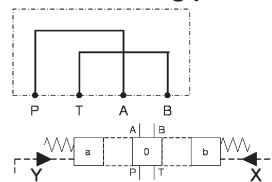

Interconnecting plate PBTA

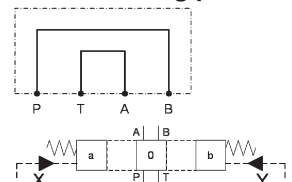

Spool position depends on interconnecting plate.

FUNCTION

The valves of the 4WH 16 series are directional spool valves with hydraulic operation which can control the start, stop and direction of the volume flow. They consist of the valve casing (1), the main control spool (2) and the return springs (3).

The fluid power supply of the valve is provided centrally via the standard porting pattern.

Without pilot oil, the main control spool is centred in its middle position by the springs. The actuation of the main control spool (2) is caused by pressurisation. The required pilot oil is provided by port X and Y or is controlled by an additional pilot valve that is adopted to the main valve. The pilot pressure depends on rate of flow. The minimal pilot pressure of 5 bar is sufficient only for low rates of flow. Pilot pressure has to be increased up to 12 bar by increasing rates of volume flow. Pressure loading on one of the two front sides of the main control spool (2) with pilot pressure causes desired switching position, whereby the required ports will be linked. The spring, which is across from the pressurised control piston surface, causes the resetting of the piston into zero or initial position by relieving of pressure.

SECTION VIEW

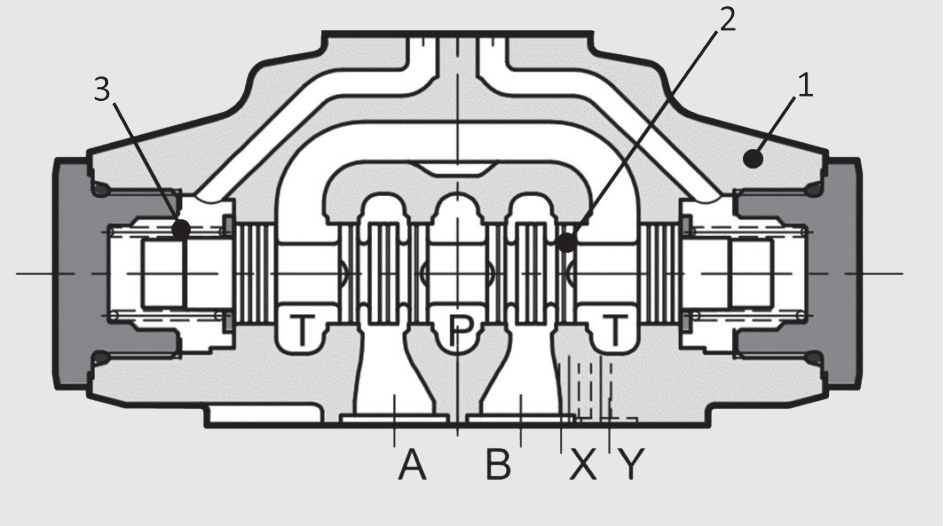

Control types – Pilot supply and pilot drain

If the valve is used as a hydraulically actuated valve, the pilot supply and pilot drain will occur external via port X and Y.

If the valve is used as main stage in a pilot-operated valve, there are four possible control types for each basic valve. This can be seen in the model code.

The valve will be delivered correspondingly configured. Modification is possible afterwards. The glued threaded plugs will make disassembly more difficult.

- **Version "E"** – Pilot supply is external from a separate fluid power supply via port X. The pilot drain is also external via port Y.
- **Version "EI"** – Pilot supply is external from a separate fluid power supply via port X. The pilot drain is internal via port T.
- **Version "IE"** – Pilot supply is internal via port P. The pilot drain is external via port Y.
Hint: Symbols G and H only with option G.
- **Version "I"** – Pilot supply is internal via port P. The pilot drain is external via port T.
Hint: Symbols G and H only with option G.

TECHNICAL DATA¹

General specifications	
MTTF _d :	150 - 1200 years, according to DIN EN ISO 13849-1:2016; Table C.1, Confirmation from ISO 13849-2:2013; Tables C.1 and C.2
Ambient temperature range: [°C]	-20 to +50
Installation position:	No orientation restrictions
Weight: [kg]	6.6
Material:	Valve casing: Cast iron Name plate: Aluminium
Surface coating:	Valve casing: Phosphate plated

Hydraulic specifications	
Operating pressure: [bar]	350
Pilot pressure min: [bar]	5 to 12 ²
Pilot pressure max: [bar]	210
Nominal flow: [l/min]	300
Operating fluid:	Hydraulic oil to DIN 51524 Part 1, 2 and 3
Media operating temperature range: [°C]	-20 to +80
Viscosity range: [mm ² /s]	10 to 400
Permitted contamination level of operating fluid:	Class 20/18/15 according to ISO 4406
Sealing material:	FKM (standard), NBR

¹ see "Conditions and Instructions for Valves" in brochure 53.000

² Pilot pressure depends on rate of delivery flow. The minimal pilot pressure is sufficient only for low rates of delivery flow. If the rate of delivery flow increases, it is necessary to increase the pilot pressure up to the specified maximum value.

PERFORMANCE

Pressure drop

measured at $v = 36 \text{ mm}^2/\text{s}$, $T = 50 \text{ °C}$

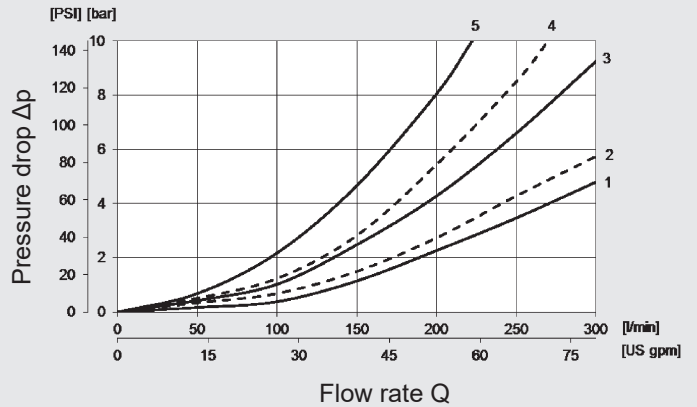

Performance limits

measured at $v = 36 \text{ mm}^2/\text{s}$, $T = 50 \text{ °C}$

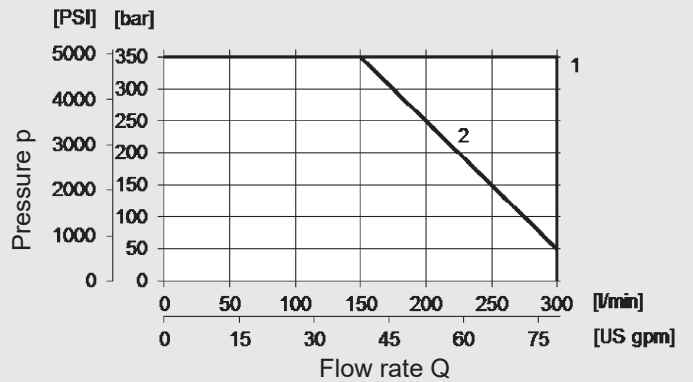

Performance assignment to the associated spools:

Spool	Switching position	Pressure drop					Performance limits
		P-A	P-B	A-T	B-T	P-T	
C	Not operated	1			4		1
	Operated		1	4			
D	Not operated	1			4		1
	Operated		1	3			
E	Not operated						1
	Operated	1	1	3	4		
J	Not operated			4●	4○		1
	Operated	1	1	4	4		
H	Not operated					2**	1
	Operated	1	1	4	4		
G	Not operated					4	2
	Operated	2	2	4	5		
L	Not operated			4			1
	Operated	1	1	3	4		
Q	Not operated						1
	Operated	1	1	3	4		
Y	Not operated		1	3			1
	Operated	1			4		

** A-B blocked ● B blocked ○ A blocked

DIMENSIONS

Interface according to ISO 4401-07-07-0-05 (CETOP 4.2-4-07-320)

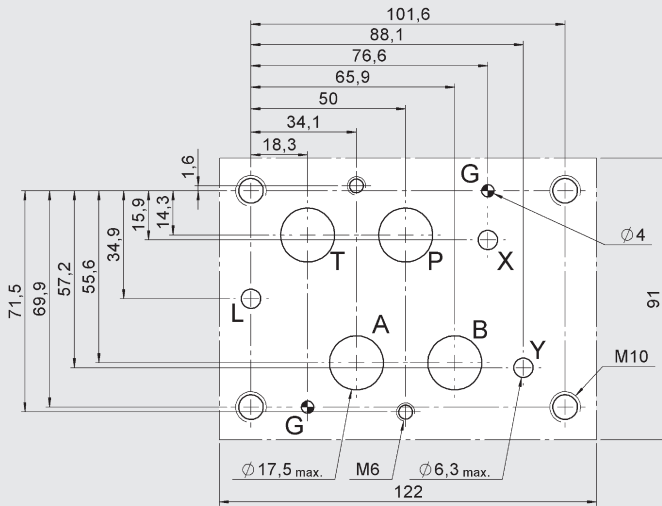

Mounting screws:

(not included in delivery)

4 screws M10x60 and 2 screws M6x50 ISO 4762

Tightening torque:

M10x60: 57 Nm (screws A 10.9)

M6x50: 14 Nm (screws A 10.9)

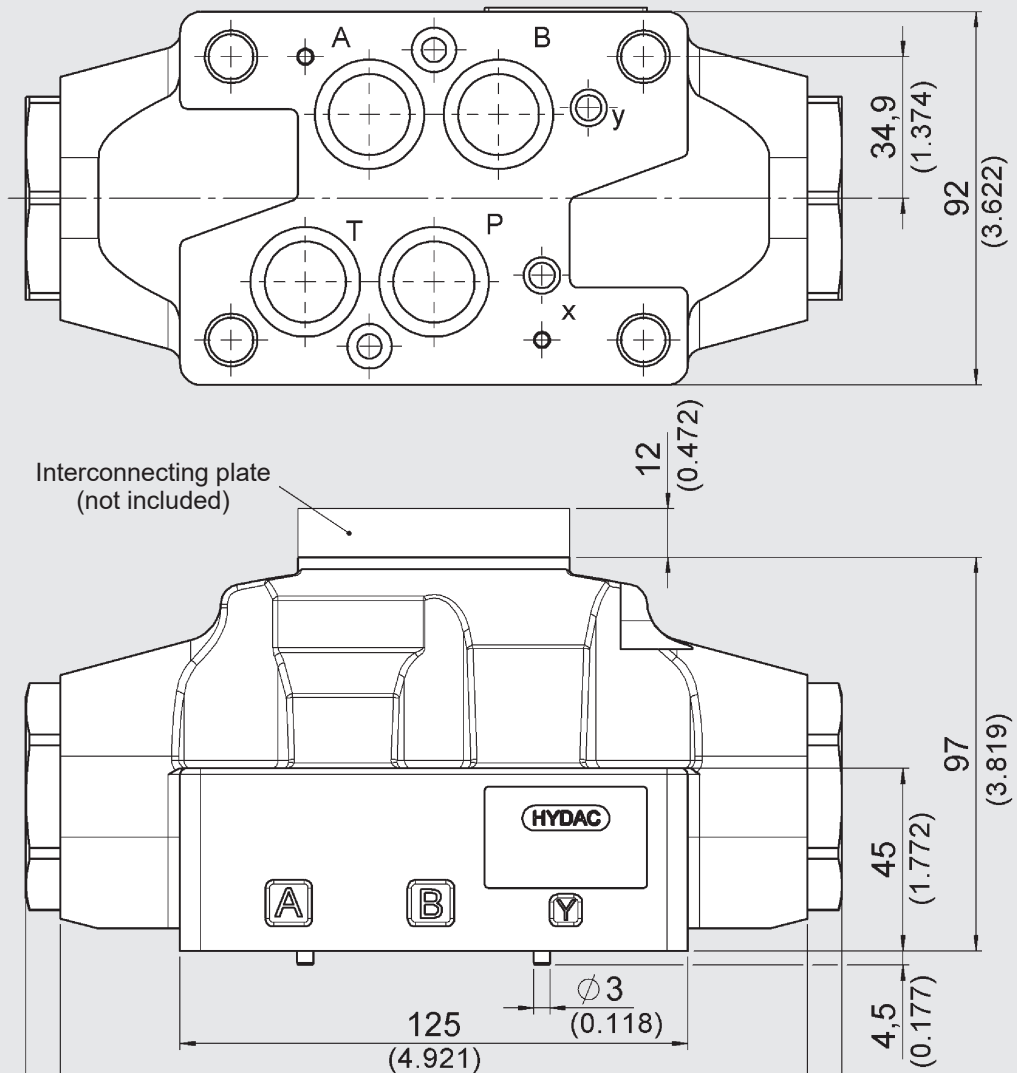

Plug

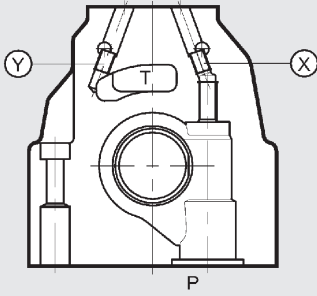

X:
M6x8 for external pilot supply

Y:
M6x8 for external pilot drain

Control type		Installation		Control
		X	Y	
E	external pilot drain and supply	•	•	hydraulically or pilot operated
EI	external pilot supply, internal pilot drain	•	–	pilot operated
I	internal pilot drain and supply	–	–	pilot operated
IE	internal pilot supply, external pilot drain	–	•	pilot operated

Plates

Check plate

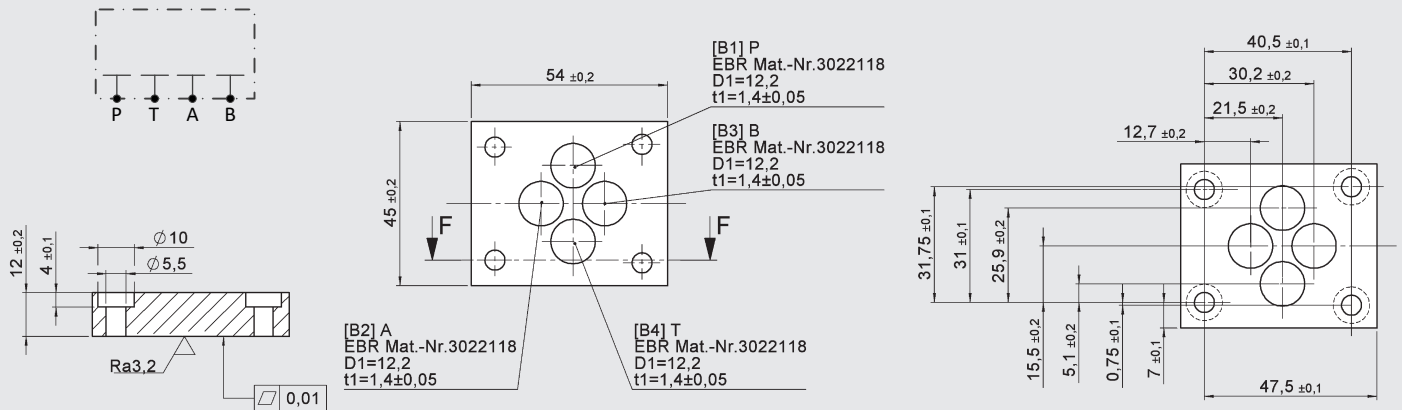

Interconnecting plates

PATB

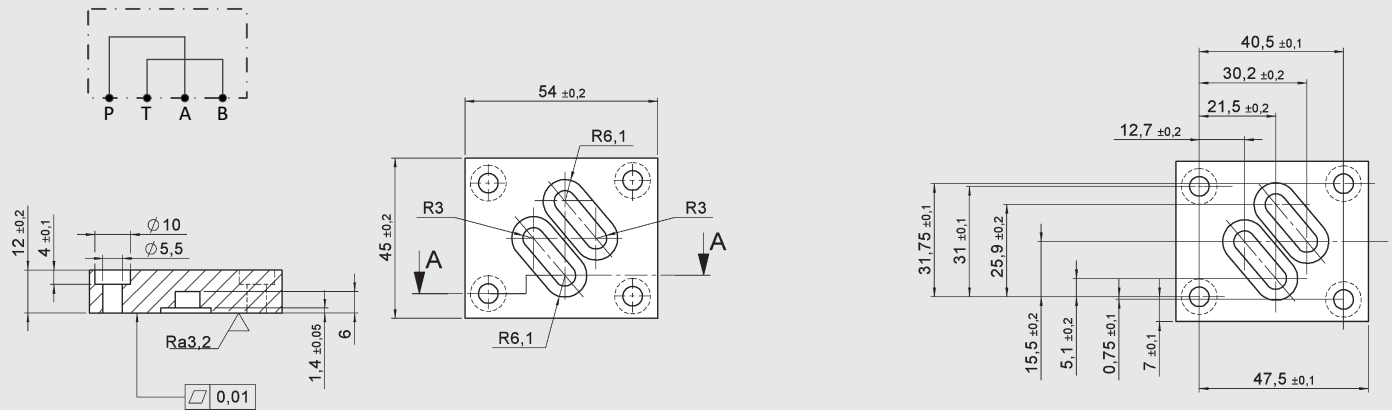

PBTA

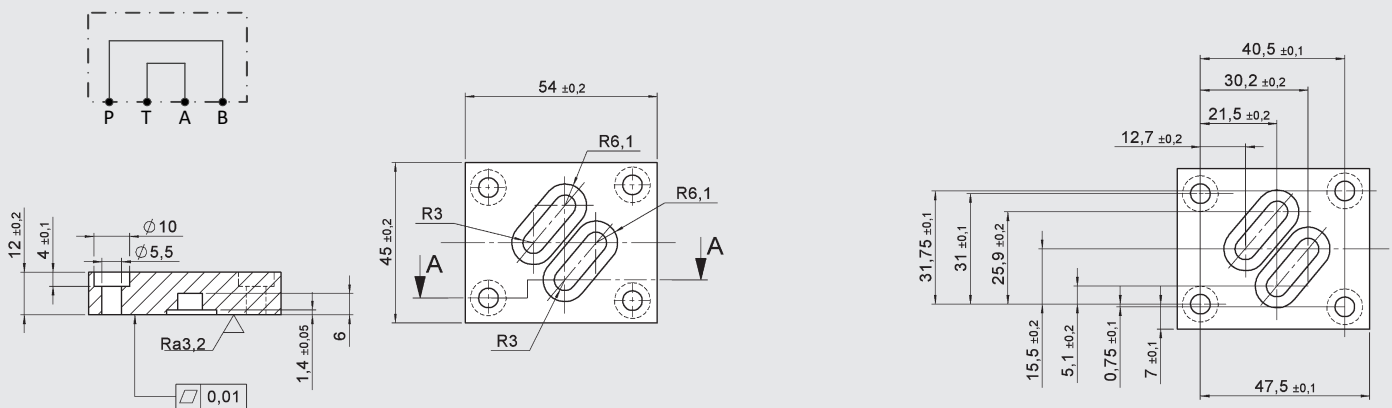

ACCESSORIES

	Designation	Part no.
Seal kits (6-part set)	22.22 x 2.62 -NBR -90 Sh (4 pieces)	3524553
	10.82 x 1.78 -NBR -90 Sh (2 pieces)	
	22.22 x 2.62 -FKM -90 Sh (4 pieces)	3524634
	10.82 x 1.78 -FKM -90 Sh (2 pieces)	
Mounting screws (6 pcs)	Screw set of M10x60 (4 pieces) and M6x50 (2 pieces)	3524695
Plug	M6x8 -45H	3524750
Plates	Check plate -NBR	3611576
	Check plate -FKM	3611580
	Interconnecting plate PATB -NBR	3581660
	Interconnecting plate PATB -FKM	3581661
	Interconnecting plate PBTA -NBR	3581662
	Interconnecting plate PBTA -FKM	3581663

Note

The information in this brochure relates to the operating conditions and applications described. For applications not described, please contact the relevant technical department. All technical details are subject to change without notice.

HYDAC Fluidtechnik GmbH
 Justus-von-Liebig-Str.
66280 Sulzbach/Saar, Germany
 Tel.: +49 68 97 /509-01
 Fax: +49 68 97 /509-598
 E-mail: valves@hydac.com

