

4/3 proportional directional valves hydraulic pilot operated with Onboard Electronic and transducer **P4WEHRE 10 to 25**

DESCRIPTION

The P4WEHRE is a pilot operated proportional directional valve with integrated electronic and transducer, which combines directional control with speed control of the consumer.

The controlled volume flow is proportional to the electrical input signal on valve electronics.

According to the input signal, the magnet generates a control pressure, which shifts hydraulically the main piston against a spring. In this process, cross-sections are released, which determine the size of the volume flow depending on the pressure difference.

The integrated digital electronics in combination with the transducer allows improved performance and function due to

- regulation of size and direction of a volume flow
- short response times
- low hysteresis
- high repeatability

FEATURES

- High flow capacity due to optimized, cast casing
- Low hysteresis due to precision machining of moving parts
- The pilot supply or pilot drain can be internal or external
- The control results directly from the integrated Onboard electronic
- Easy interchangeability due to internationally standardised interface according to ISO 4401

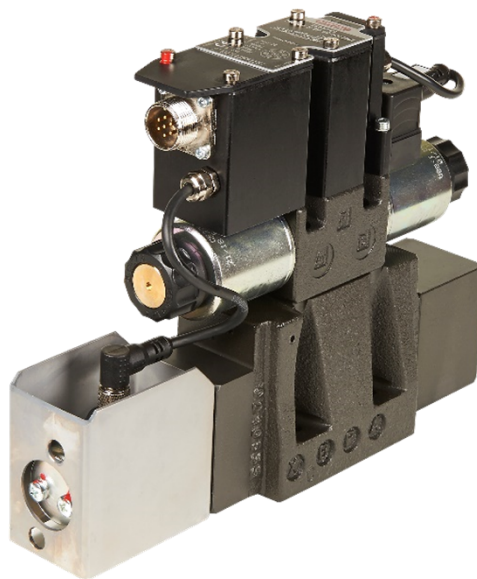

CONTENT

Description	1
Features	1
Model code	2
Spool types / Symbols	3
Technical Data	3
Function	4
Section view	4
Accessories	4
Performance	5
Dimensions	7
Electronic	10

MODEL CODE

P4WEHRE E 10 E80 D01-24PG E0B/V/D

Type

Proportional 4 directional valve, electrical / hydraulic with Onboard Electronic (OBE) and transducer

Control type

E = external pilot supply and drain
EI = external pilot supply, internal pilot drain
IE = internal pilot supply, external pilot drain
I = internal pilot supply and drain

Nominal size (NG)

10, 16, 25

Symbols

See page 3

Nominal flow (at $\Delta p = 10$ bar, P – T)

80 = 80 l/min
80/40 = 80 l/min (P → A or A → T) / 40 l/min (B → T or P → B)
further nominal flows see page 4 „Nominal flow ranges“
in chart „Hydraulic specifications“

Series

D01 = standard
D02 = ISO 4401-05-05-0-05 (NG10 only)

Rated voltage of the solenoid coil

24 = 24 V DC

Coil Type

PG = 7-pin MIL-C-5015-G (DIN-EN 175201-804)

Input signal

E0 = ± 10 V
E1 = 4 – 20 mA

Pin C Function

see „Diagrams Pin C Function“ on page 11

Sealing material

V = FKM (standard)
N = NBR

Pressure reducing valve (30 bar fixed)

Necessary if control pressure at port X is higher than 210 bar

KOLBENTYPEN / SYMBOLE

4/2-DIRECTIONAL SPOOL VALVES

Type	Basic model
EA	
JA	

4/3-DIRECTIONAL SPOOL VALVES

Type	Basic model
E	
J	

TECHNICAL DATA ¹

General specifications

		Nominal size		
		10	16	25
MTTF _d :		150 - 1200 years, according to DIN EN ISO 13849-1:2016; Table C.1, confirmation of ISO 13849-2:2013; Tables C.1 and C.2		
Ambient temperature:	[°C]	-20 to +60		
Installation position:		No orientation restrictions		
Weight:	[kg]	9,0	11	17,5
Material:		Valve casing:		Cast iron
		Name plate:		Aluminium
Surface coating:		Valve casing:		Phosphate

Hydraulic specifications

		Nominal size		
		10	16	25
Operating pressure:	[bar]	Port P: p _{max} = 350 Port T, internal leak port: p _{max} = 10 Port T, external leak port: p _{max} = 250		
Control pressure:	[bar]	p _{min} = 30 p _{max} = 210		
Max. nominal flow:	[l/min]	180	450	800
Nominal flow ranges: (at Δp = 10 bar, P → T)	[l/min]	80 80/40	100 150 150/75	200 300 300/150
Operating fluid:		Hydraulic oil to DIN 51524 part 1, 2 and 3		
Media operating temperature range:	[°C]	-20 to +80		
Viscosity range:	[mm ² /s]	10 – 400		
Permitted contamination level of operating fluid:		class 18/16/13 to ISO 4406		
Sealing material:		NBR, FKM (standard)		
Control flow: (Control 0 → 100 %)	[l/min]	3,5	6,4	15,3
Control volume: (Control 0 → 100 %)	[cm ³]	1,7	3,2	9,2

Electrical specifications

		Nominal size		
		10	16	25
Switching time (0 → 100%):	[ms]	50	50	60
Switching time (100% → 0):	[ms]	40	40	40
Type of voltage:		DC		
Rated voltage:	[V]	12, 24		
Hysteresis:	[%]	< 0,5 of Q _{max}		
Repeatability:	[%]	< ±0,2 of Q _{max}		
Protection class to DIN EN 60529:		with electrical connection "G" IP65 ²		

Hint

If the system pressure exceeds the max. allowable control pressure, it is necessary to use the version with external control and control pressure within the specifications. Otherwise, the valve with internal pilot control and pressure reducing valve as 30 bar fixed sandwich plate can be ordered.

¹ see „Conditions and Instructions for Valves“ in brochure 53.000

² if installed correctly

FUNCTION

The P4WEHRE is a hydraulic pilot operated, proportional 4 directional valve with integrated OBE and transducer.

The volume flow is controlled continuously (proportionally) to the electrical input signal at the solenoid coil.

These valves essentially consist of the pilot stage (pressure regulating valve) and the main stage (directional valve).

The pilot stage consists of the valve housing (1), a control piston with 2 pressure measuring pins (2) and two proportional solenoids (3). The proportional solenoid coils are controlled via the integrated Onboard electronic (7). OBE and pilot stage are connected via the main connector (8). The main stage consists of the housing (4), a main piston (5) and a centring spring (6) acting in both directions.

The transducer (9) in the main stage monitors the position of the main piston.

The pressure supply of the valve results from the interface according to ISO 4401. The external pilot supply and drain result from port X and Y to the pilot valve. The regulated control pressure is proportional to the stroke of the main stage. If one of the two solenoids is energized, the pilot releases the connection to control port A or B and regulates the control pressure according to the set solenoid current.

The main piston shifts until a balance of force is reached by pressurizing one of the two sides of the main piston via control pressure. The desired connection PABT or PBAT is released. The transducer makes a target-performance comparison of the main piston position and corrects differences via OBE.

If the valve is subsequently relieved of pressure, the centring spring returns the main piston to neutral again.

P4WEHRE valves are available in different versions, which differ in their interface. Due to this difference, the valve versions are not compatible with each other.

SECTION VIEW

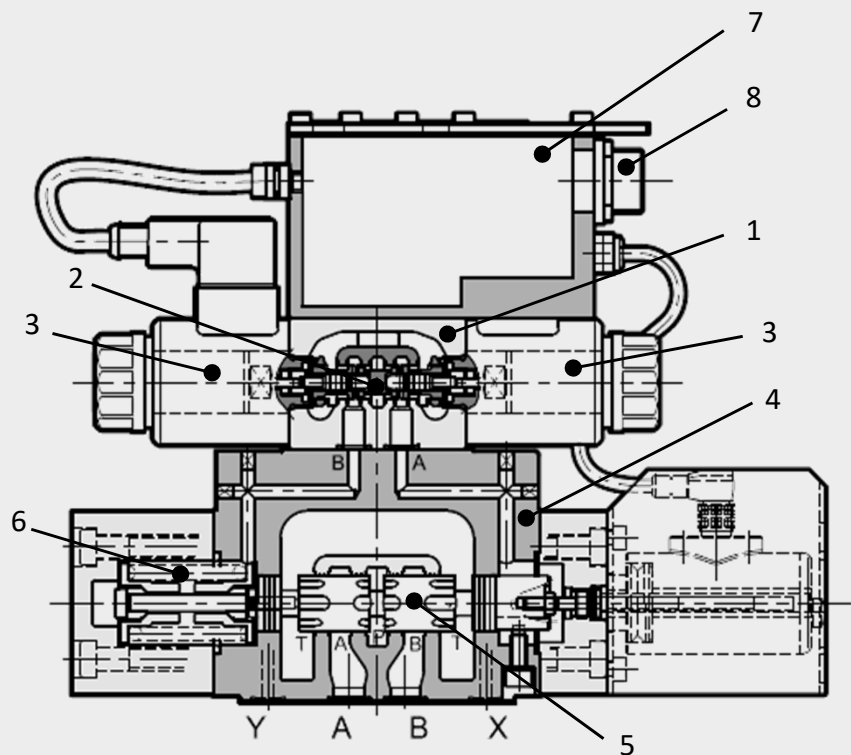

ACCESSORIES

	Designation	Part no.
Seal kits (main stage)	P4WEHRE 10: 12,42 x 1,78 90 Sh (5 pcs) 9,25 x 1,78 90 Sh (2 pcs)	FKM: 3524523 NBR: 3524475
	P4WEHRE 16: 22,22 x 2,62 90 Sh (4 pcs) 10,82 x 1,78 90 Sh (2 pcs)	FKM: 3524634 NBR: 3524553
	P4WEHRE 25: 29,82 x 2,62 90 Sh (4 pcs) 20,24 x 2,62 90 Sh (2 pcs)	FKM: 3524660 NBR: 3524659
	P4WEHRE 10: ISO 4762 M6 x 35 (4 pcs) P4WEHRE 16: ISO 4762 M10 x 60 (4 pcs) ISO 4762 M6 x 60 (2 pcs) P4WEHRE 25: ISO 4762 M12 x 60 (6 pcs)	604593 4501973 4501973 619501
Main Connector	6+PE EN175201 Part 804	6080324
Electronic	Lin-Bus Interface	3648934

PERFORMANCE

The performance represent typical curves for the various available valve pistons, at a constant Δp , depending on the current supplied by the solenoid coil.

(Note: The maximum current for the solenoid version D24 is 800 mA).

The total valve pressure drop (Δp) was measured between port P and T of the valve.

Q-I-Performance NG10

(measured at 36 cSt, 50°C), symbols E; EA; EB; J; JA; JB, nominal flow 80 l/min

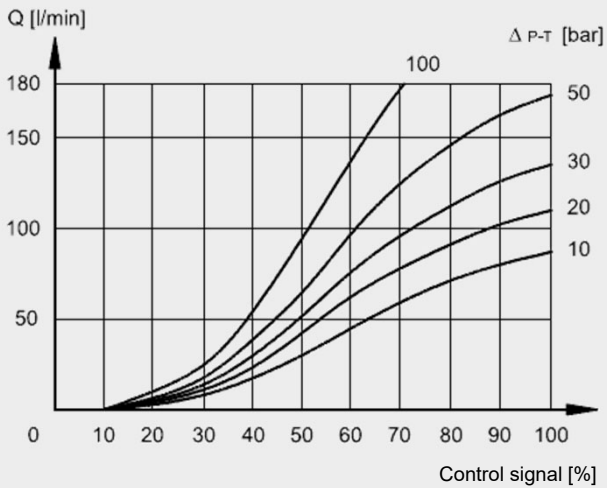

Q-I-Performance NG16

(measured at 36 cSt, 50°C), symbols E; EA; EB; J; JA; JB, nominal flow 100 l/min

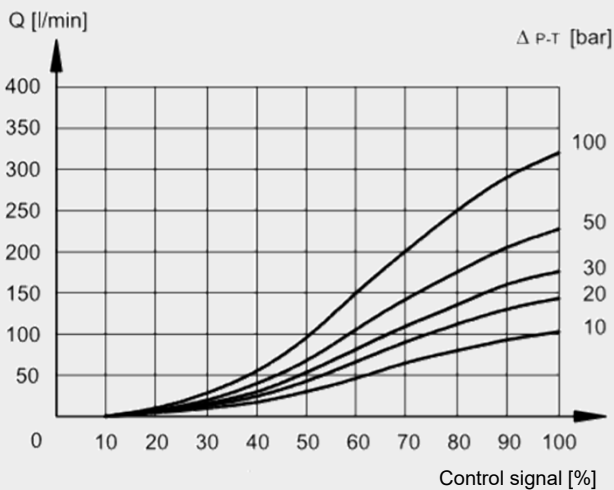

Nominal flow 150 l/min

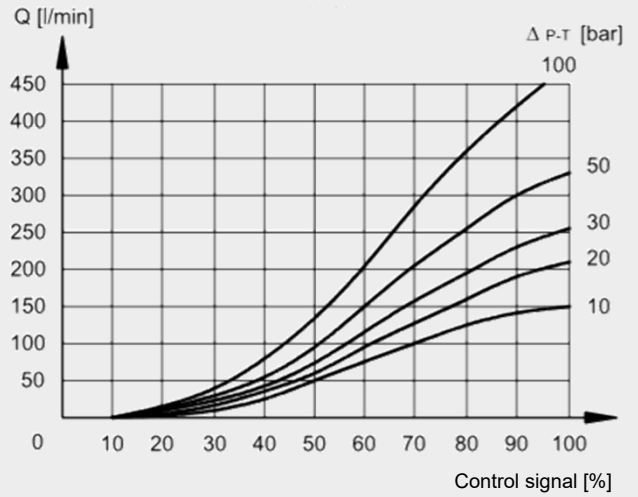

Q-I-Performance NG25

(measured at 36 cSt, 50°C), symbols E; EA; EB; J; JA; JB, nominal flow 200 l/min

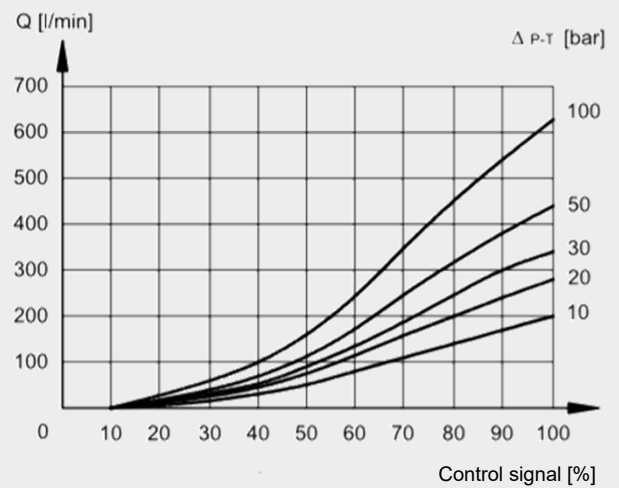

Nominal flow 300 l/min

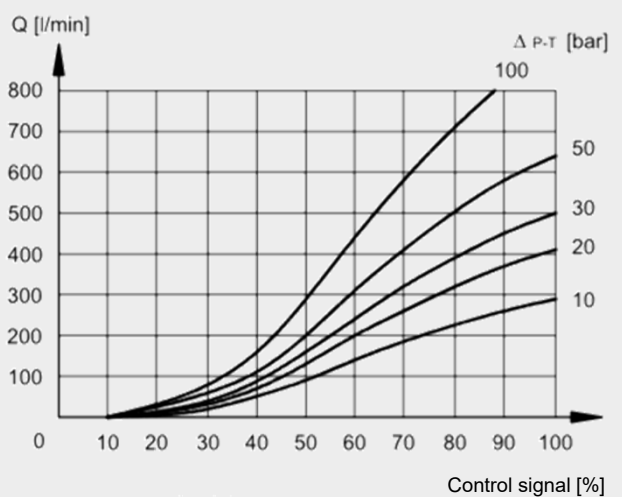

PERFORMANCE

Switching time (measured at 36 cSt, 50°C), symbols E, EA, EB, J, JA

NG10

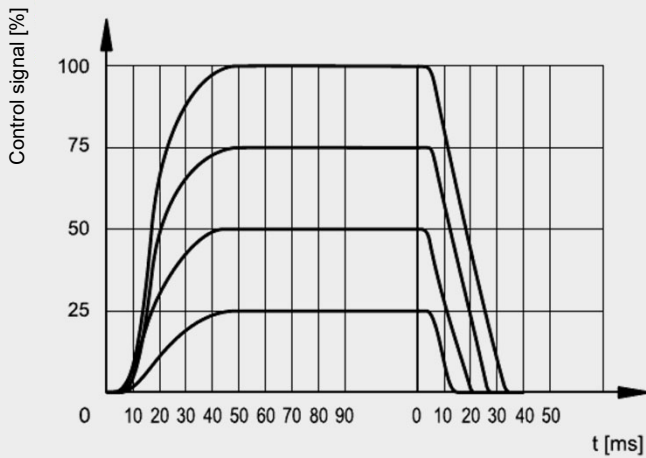

NG16

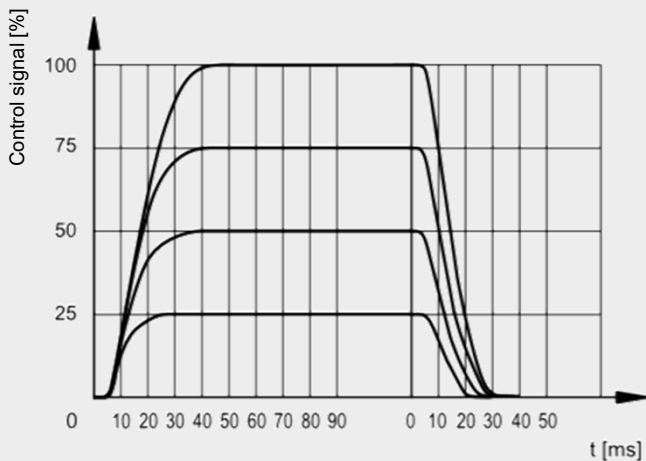

NG25

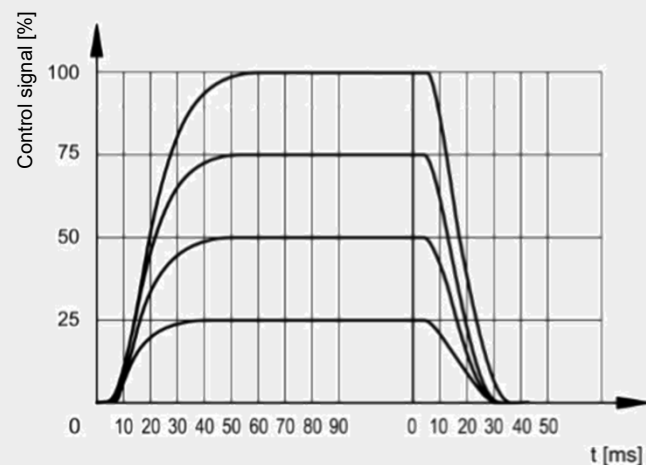

Plug

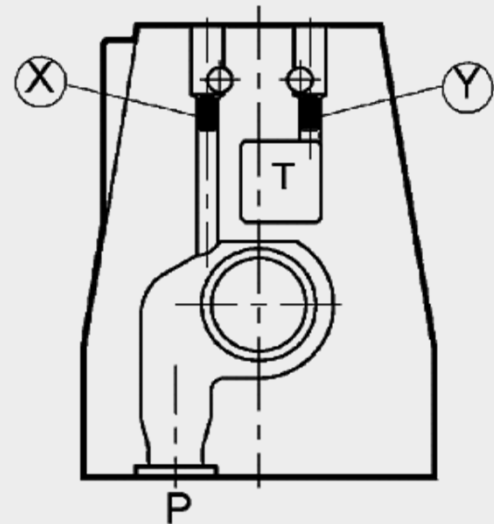

Control type		Installation	
		X	Y
E	external pilot supply and drain	●	●
EI	external pilot supply, internal pilot drain	●	-
IE	internal pilot supply, external pilot drain	-	●
I	internal pilot supply and drain	-	-

- **Version „E“**
Pilot oil supply is external from a separate fluid power supply via port X.
The pilot oil drain is also external via port Y.
- **Version „EI“**
Pilot oil supply is external from a separate fluid power supply via port X.
The pilot oil drain is internal via port T.
- **Version „IE“**
Pilot oil supply is internal via port P.
The pilot oil drain is external via port Y.
- **Version „I“**
Pilot oil supply is internal via port P.
The pilot oil drain is internal via port T.

The valve is configured and delivered as required.
The threaded plugs are glued in at delivery.
Subsequent modification is not possible.

DIMENSIONS NG10

INTERFACE

CETOP 4.2-4 P05-350 (D01)

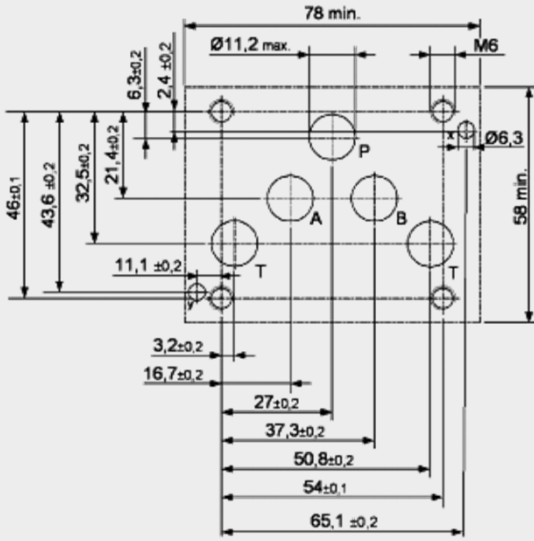

INTERFACE

ISO 4401-05-05-0-05 (D02)
(CETOP 4.2-4 R05-350)

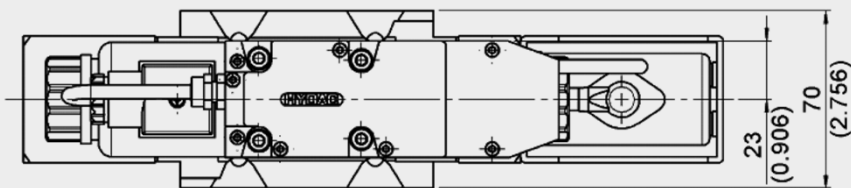
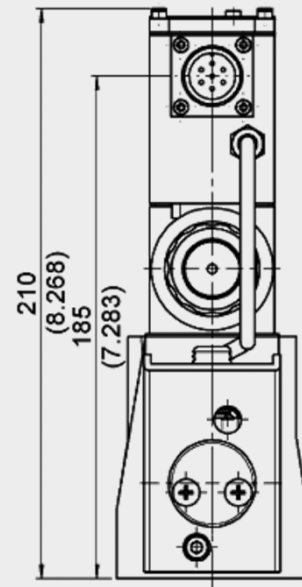
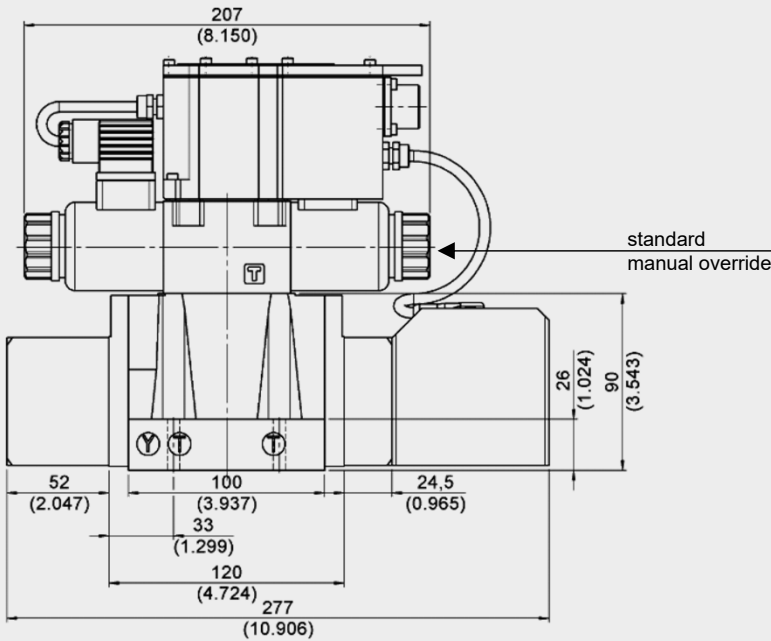
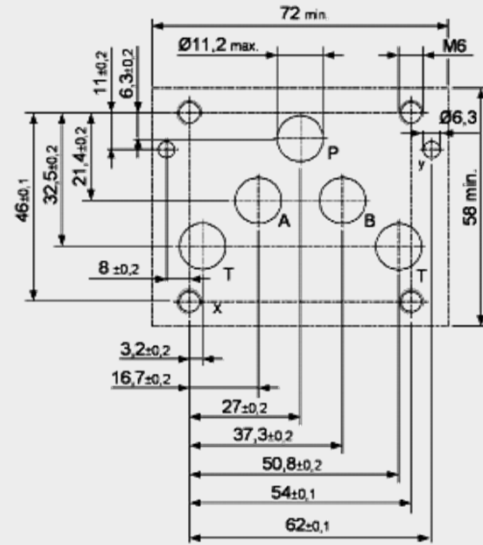

Hint

When using the pressure reducing as sandwich plate, the installation height changes by 40 mm to 250 mm.

Mounting screws (ISO 4762): 4 pcs M6 x 35 A8.8 (not included in delivery)
Torque: 8 Nm

DIMENSIONS NG16

INTERFACE

ISO 4401-07-07-0-05 (D01)
(CETOP 4.2-4-07-350)

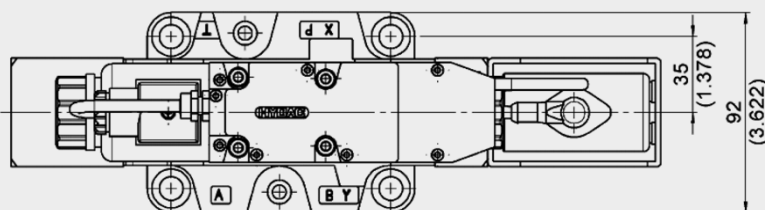
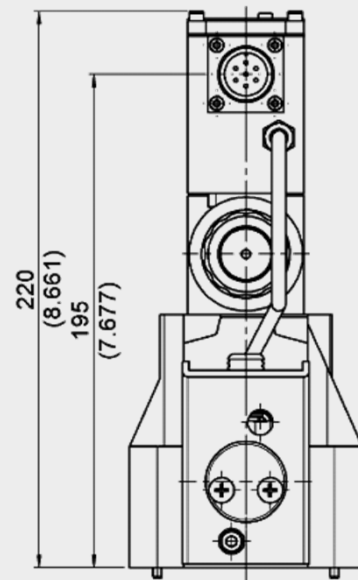
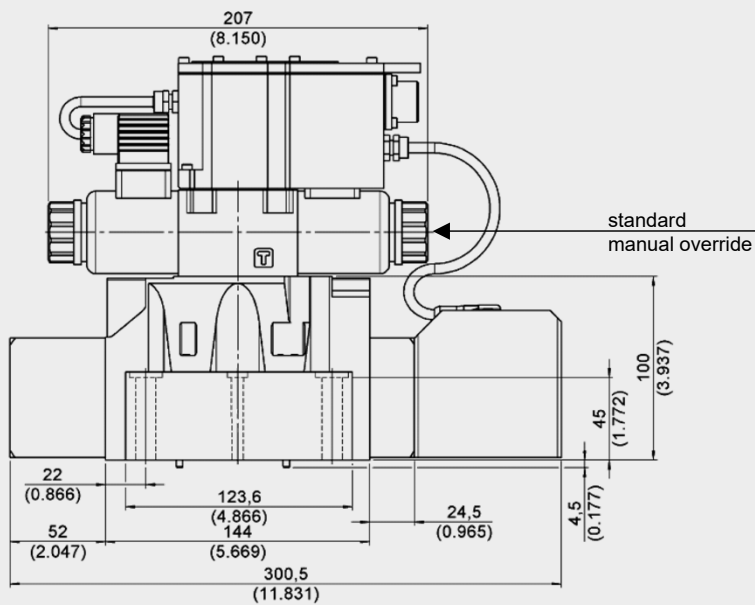
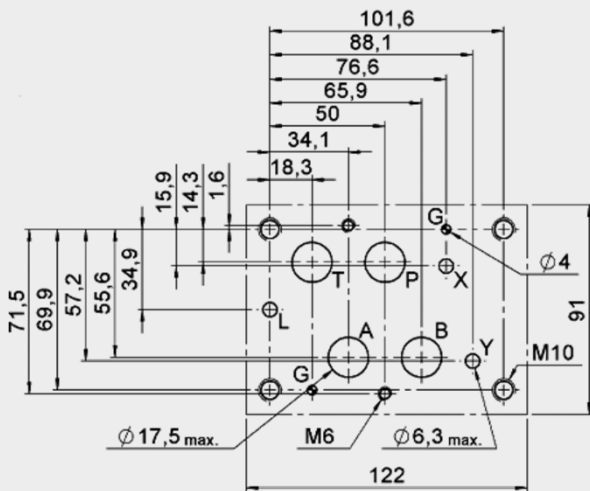

Hint

When using the pressure reducing as sandwich plate, the installation height changes by 40 mm to 260 mm.

Mounting screws (ISO4762): 4 pcs M10x60 A8.8 (not included in delivery)
2 pcs M6 x 60 A8.8 (not included in delivery)

Torque: M10: 40 Nm
M6: 8 Nm

DIMENSIONS NG25

INTERFACE

ISO 4401-08-08-0-05 (D01)
(CETOP 4.2-4-08-350)

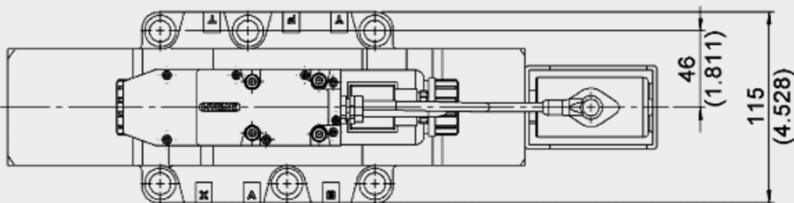
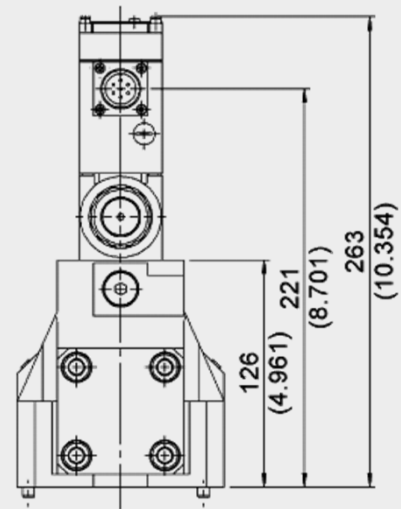
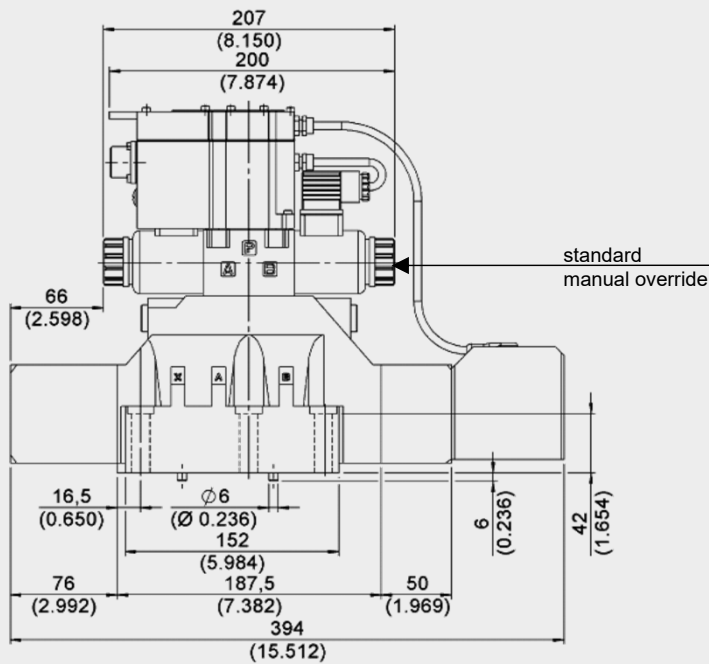
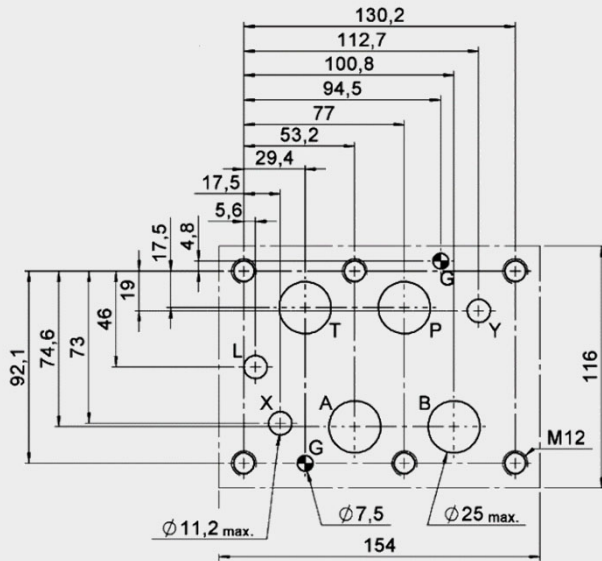

Hint

When using the pressure reducing as sandwich plate, the installation height changes by 40 mm to 303 mm.

Mounting screws (ISO4762): 6 pcs M12x60 A8.8 (not included in delivery)
Torque: 69 Nm

INTEGRATED ELECTRONIC

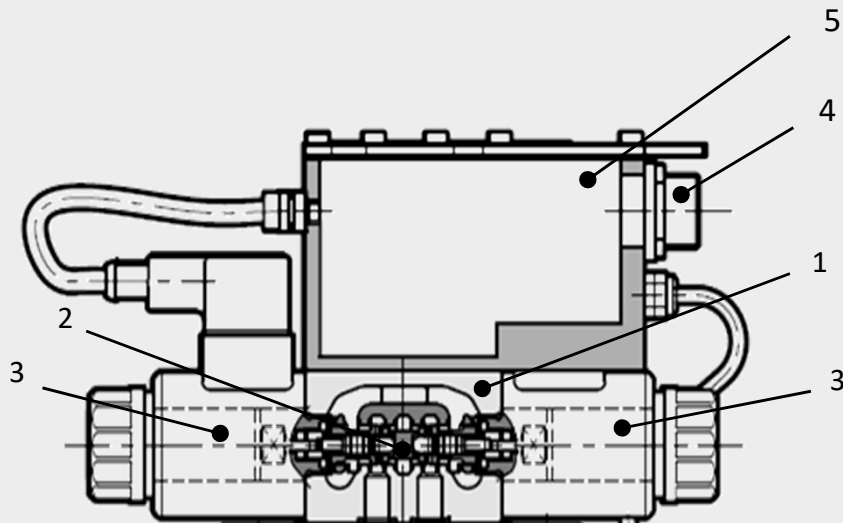

Parameterisable only via LIN bus

- 1) Valve with proportional solenoids
- 2) Valve piston
- 3) Proportional solenoid
- 4) Main connector
- 5) Electronic housing

General specifications

Power consumption:	25 W
Current consumption:	max. 1,88 A
Rated voltage:	24 V DC (19 – 30 V DC, ripple max. 3 Vpp)
Duty cycle:	100% ED (continuous)
Control signal E0:	Voltage signal ± 10 VDC
Control signal E1:	Current signal 4 – 20 mA
Alert signale:	Overload and overheating of electronics
Communication:	LIN-Bus ISO 11898 LIN-Bus Interface
Electronical connection:	7-pin MIL-C-5015-G (DIN-EN 175201-804)
LIN-Bus connection:	M12-IEC 60947-5-2
EMC EN61000-6-4:	According to 2014/30/EU standard
EMC EN61000-6-2:	According to 2014/30/EU standard
Type of protection:	IP65 / IP67 (CEI EN 60529 standard)

ELECTRONIC

Standard version with reference signal voltage E0

PIN	Value	Version A	Version B	Version C
A	24 V DC	Supply voltage		
B	0 V			
C		release 24 V DC	unoccupied	PIN F reference 0 V
D	+/- 10 V	control (differential input)		
E	0 V	PIN D reference		
F	+/- 10 V	monitor (0V reference PIN B)		monitor
PE	GND	earth (mass)		

Standard version with reference signal current E1

PIN	Value	Version A	Version B	Version C
A	24 V DC	Supply voltage		
B	0 V			
C		release 24 V DC	unoccupied	PIN F reference 0 V
D	4 - 20 mA	control		
E	0 V	PIN D reference		
F	4 - 20 mA	monitor (feedback) (0V reference PIN B)		monitor (feedback)
PE	GND	earth (mass)		

Diagrams PIN C Function

Version A: External release (on request)

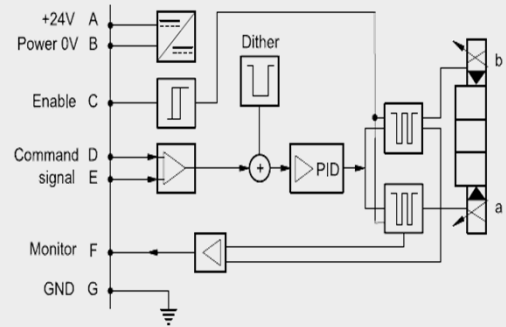

Version B: Internal release (standard)

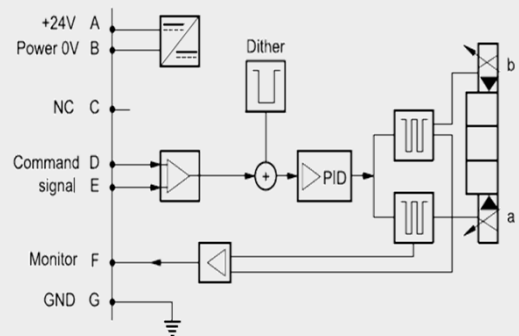

Version C: 0V Monitor (on request)

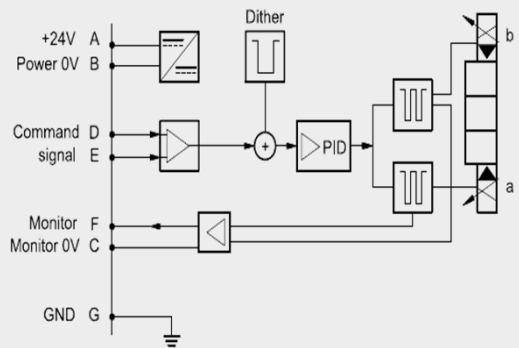

Hint 1

- Voltage signal (0V centring position)
 - -10V to 0 V: flow direction P – B and A – T
 - 0V to +10V: flow direction P – A und B – T
- Current signal (12 mA centring position)
 - 4 mA to 12 mA: flow direction P – B and A – T
 - 12 mA to 20 mA: flow direction P – A and B – T
- With one solenoid (type EA and JA)
 - 4 mA to 20 mA: flow direction P – B and A – T
 - 0V to +10V: flow direction P – B and A – T

Pin D and Pin E must always be contacted.

Hint 2

PIN C function A and B: Nominal input value measured between pin F and pin B.

Hint 3

We recommend to provide an external protection at pin A (24 V DC) for protection of the electronics: 5A/50V fast fuse.

LIN-BUS INTERFACE

Is also required for parameterisation of Onboard electronic.

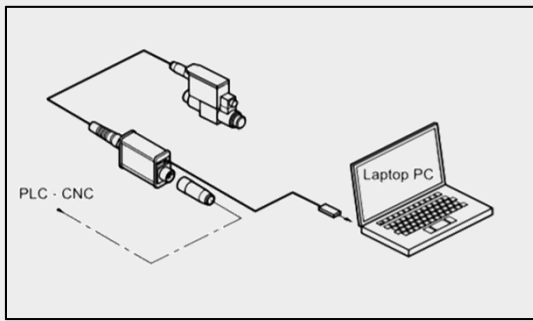

- The kit contains a test device with embedded connection cable 7 pin and a USB cable for connection to the PC. The dedicated software are available for download from our website.
- The device is suitable for troubleshooting and functional testing of HYDAC proportional valves with LIN-bus interface.
- The software allow the check of settings, display the diagnostic and permit to make changes on the standard parameter setting made in factory, adapting it to your system.
- No additional power supply is required: the device uses the supply source from the 7 PIN system cable.

Content*: Parameterize-software, adapter and PC connection cable

* On request (not included in delivery)

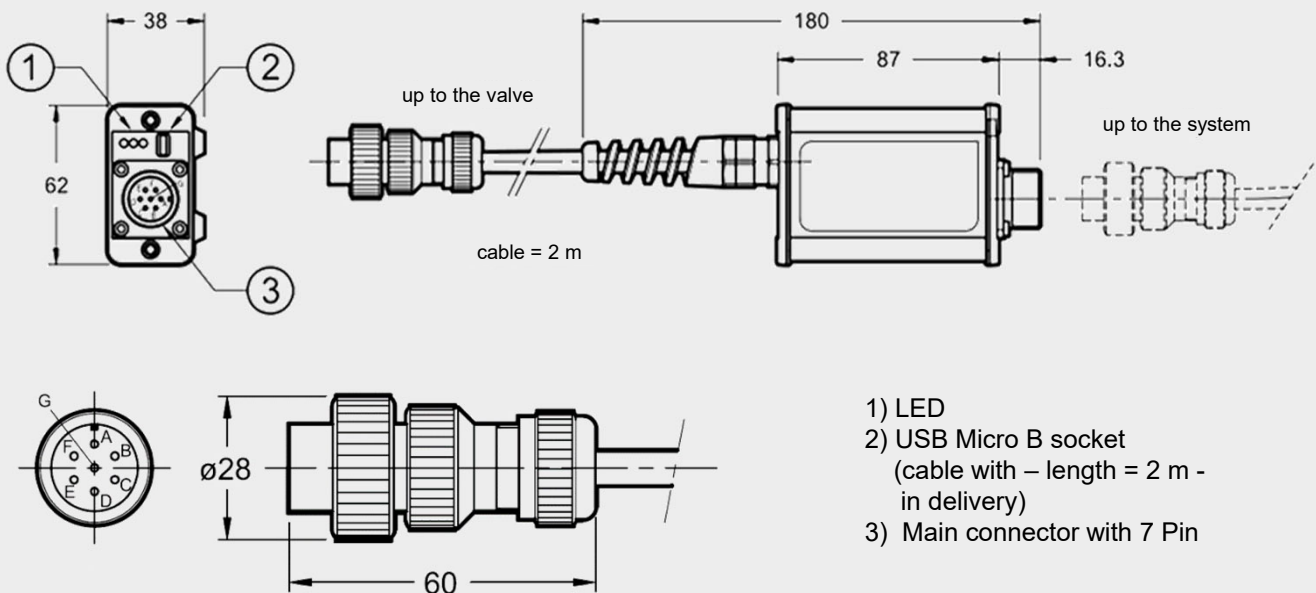

In the casing of electronics, a 7-pole port for connecting with external devices is integrated.

The cable diameter for the main connector (cable and connector are not included in delivery) has to be min. 8 mm and should be max. 10 mm.

Hint

We recommend the use of a metal connector to ensure electromagnetic compatibility (EMC) and to avoid electromagnetic disturbances.

Note

The information in this brochure relates to the operating conditions and applications described. For applications not described, please contact the relevant technical department.

All technical details are subject to change without notice.

HYDAC Fluidtechnik GmbH
 Justus-von-Liebig-Str.
D-66280 Sulzbach/Saar
 Tel: 0 68 97 /509-01
 Fax: 0 68 97 /509-598
 E-Mail: valves@hydac.com