



Monoblock Directional Control Valve RM 270 light

Preliminary Version

Key valve features

The RM 270 light is a monoblock valve, designed for max. operating pressures up to 210 bar and max. pump flows up to 120 l/min.

It is available with 1, 2, 3, 4, and 6 sections per valve.

The valve is designed with an open center for fixed displacement pumps.

The valve can be operated manually or by pneumatic and electro-pneumatic remote control.

The "SuperRapid"-range of the valve is optimized for maximum lowering flow of 185 l/min and allows lowering at the same time as another function is pressurized without the use of pump flow.

The valve offers excellent operating characteristics because of the specially designed spools for different applications.

Low and uniform spool forces are the result of careful balancing of the flow forces.

Applications

Typical applications are cranes, tippers, refuse trucks, multi-bucket systems and roller container vehicles. Several special versions of RM 270 light fulfil many other applications.

Technical data

Pressures / Flows

Max. operating pressure per port:

P1, P2, A, B: 210 bar

T1, T2: 20 bar

Max. permissible flow either on port P1 or P2: 120 l/min

Fluid temperature range: -15 °C up to +80 °C

Further data

Spool stroke:

Nominal: +/- 7 mm

4:th position: + 14 mm

Spool control force spool control 9:

Neutral position: 130 N

Max. spool stroke: 155 N

Permissible contamination level: Equal or better than 20/18/14 as per ISO 4406

Viscosity range: 10 – 400 mm²/s (cst)
Higher viscosity allowed at start up

Leakage A, B → T at 100 bar, 32 cst and 40 °C: ≤20 cc/min

Pressure fluid: Mineral oil and synthetic oil based on mineral oil HL, HLP according to din 51524

Higher values are possible, depending on application. For applications with data that exceeds stated data above, please contact us for consideration.

MTTFd value after consultation with HYDAC.

Further properties and possibilities

- Each section can be provided with a pressure relief valve, an anticavitation valve or a combination of these
- There are many varieties of spools and spool controls which make the valve suitable for a wide range of applications
- Two or more blocks can be connected in series
- The valve can be supplied with a built-in unloading valve, which in an emergency situation makes it possible to let all the pump flow go to tank at a very low pressure drop
- A combination of built-in flow control-, unloading- and counter pressure valves gives a compact solution and less mounting parts for refuse trucks

- Possibility for built-in load holding valves
- In systems with demand for both high and low flows the valve can be combined with RS 210. The adapter between the valves includes a flow control valve for reduced flow to the RS 210 working sections

Pressure drop

Oil temperature / viscosity for all graphs: +40 °C / 32 cSt

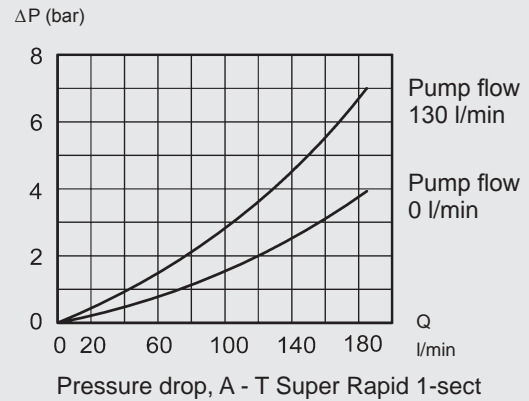
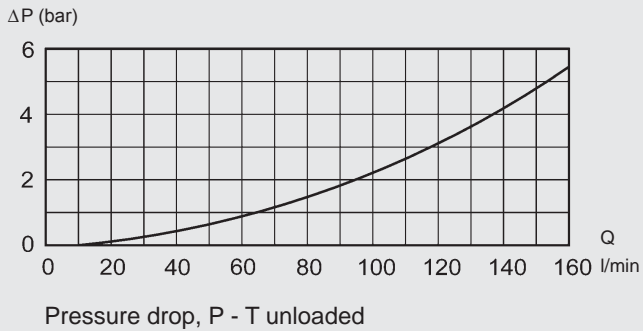
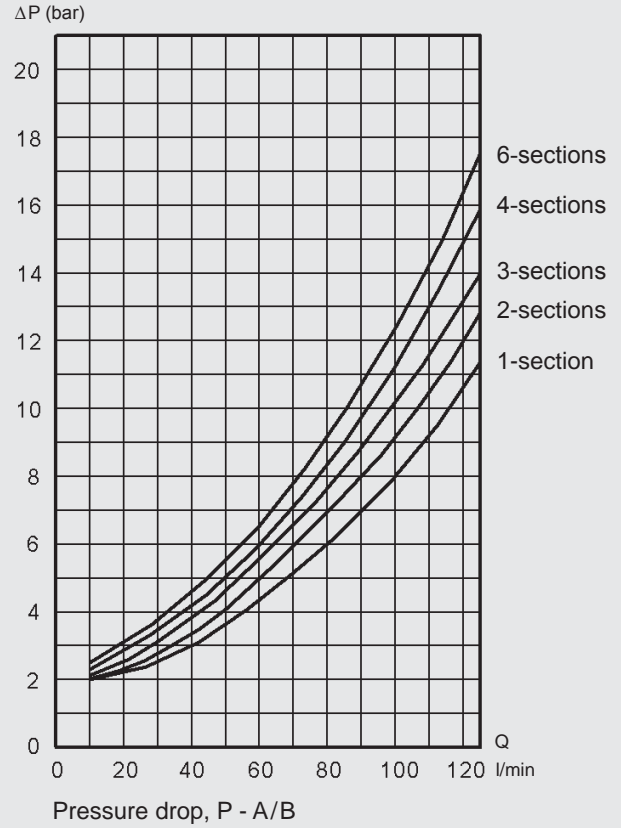
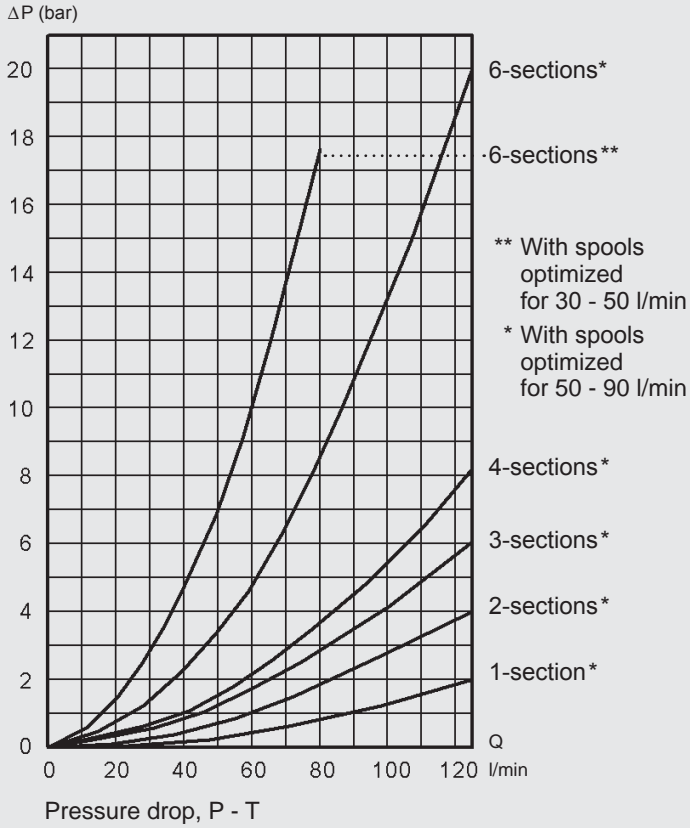

Dimensions and Weight

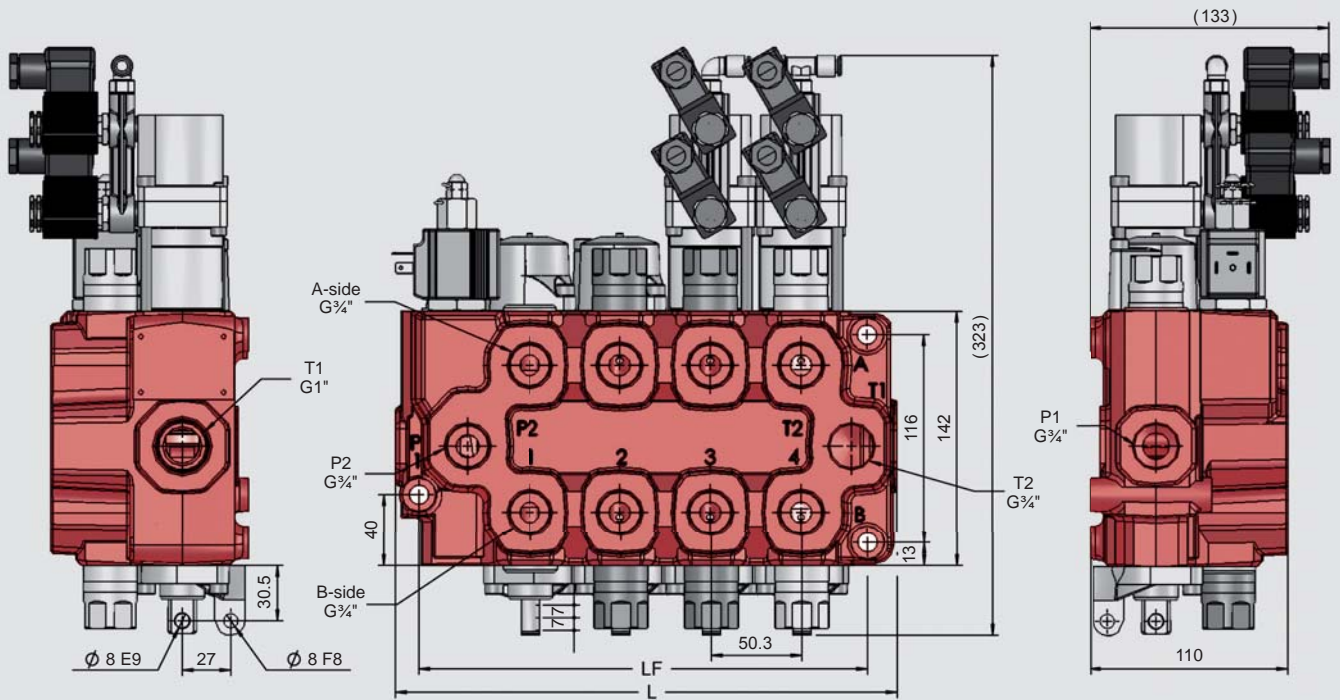

Weights	Complete valve
1 section	11 kg
2 sections	15 kg
3 sections	19 kg
4 sections	23 kg
6 sections	31 kg

Measurements	L [mm]	LF [mm]
1 section	128	100
2 sections	178.3	150
3 sections	228.6	200
4 sections	278.9	250
6 sections	379.5	350

Spool stroke:	+/-7 mm
Float position:	+14 mm

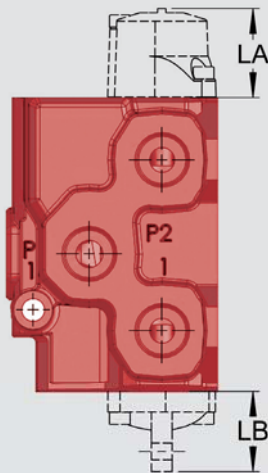

Type	LA [mm]	LB [mm]
9	43	
10	43	
11	75	
13	75	
14	75	
P	109	
P5	157	
EP	109	
MSLA	48.5	
M19		38.5
M211		32
M212		55.5

Main Relief Valve

Main Relief Valve TBD200

The TBD200 is a differential area, direct acting relief valve for the main circuit.

- Adjustable and sealable
- Setting range: 35 – 210 bar (3.5 – 21.0 MPa)
- Setting range step: 5 bar

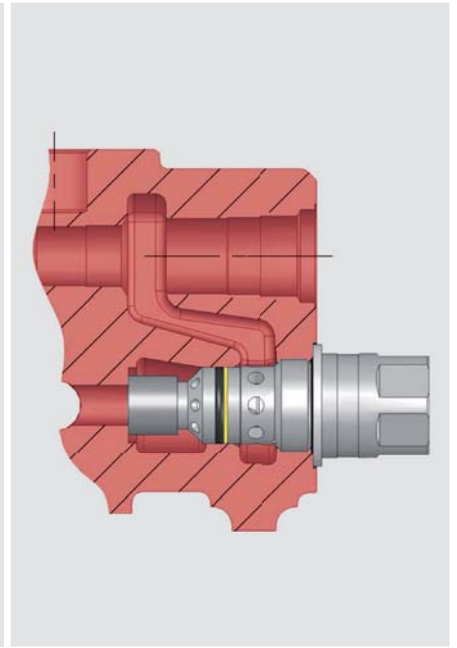
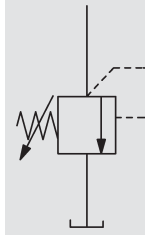
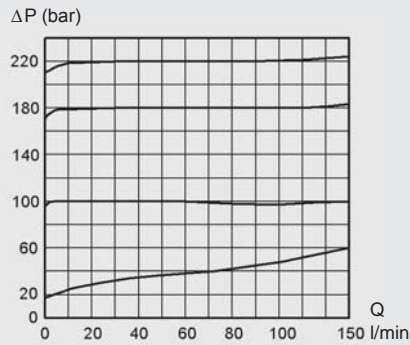

Service Port Valves

Port Relief Valve TBD205

The TBD205 is a differential area, direct acting relief valve for the secondary circuit.

- Adjustable and sealable
- Setting range: 40 – 210 bar (4.0 – 21.0 MPa)
- Setting range step: 10 bar

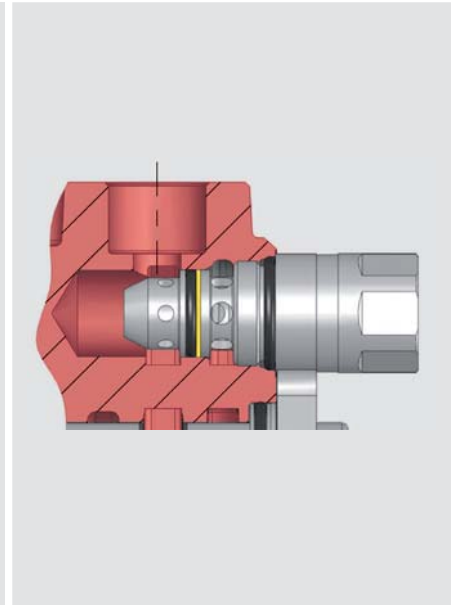
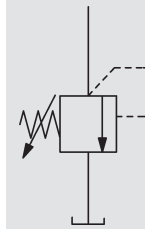
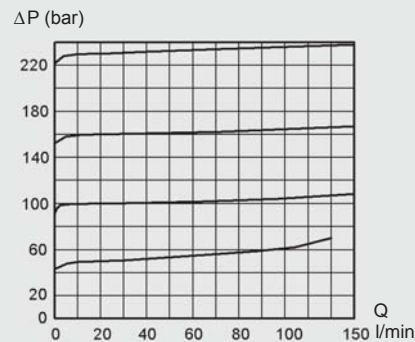

Port Relief and Anticavitation Valve TBSD205

The TBSD205 is a differential area, direct acting relief and anticavitation valve for the secondary circuit.

- Adjustable and sealable
- Setting range: 40 – 210 bar (4.0 – 21.0 MPa)
- Setting range step: 10 bar

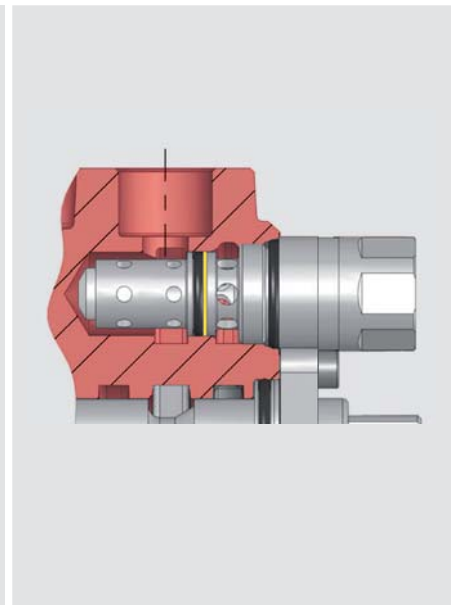
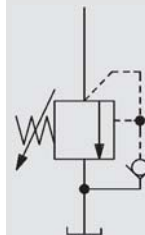
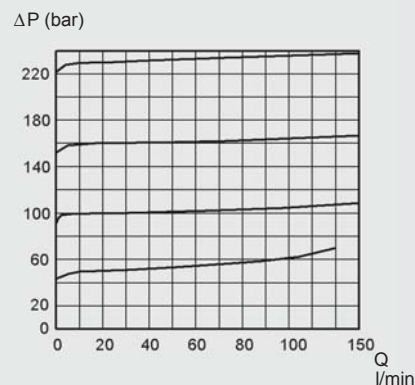

Anticavitation Valve SB205

The anticavitation valve service to ensure that, in the event of a lower pressure in the cylinder port than in the tank, oil can be drawn from the system oil tank to the consumer.

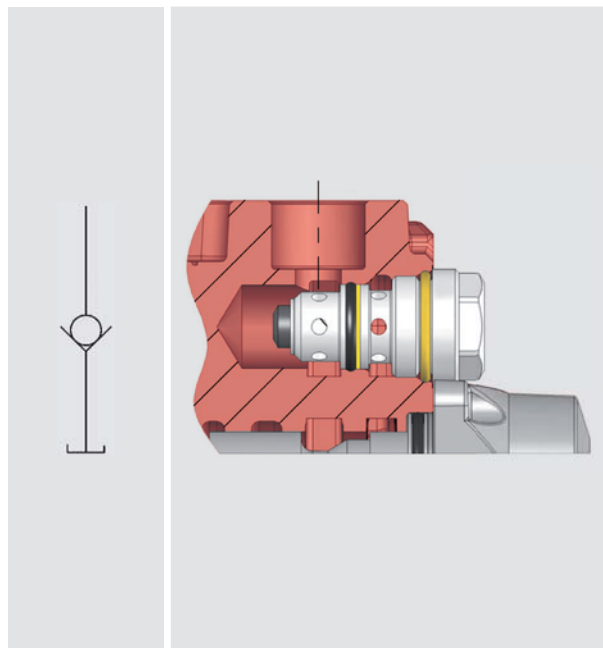
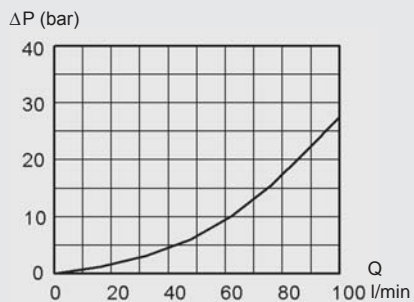

Electrical Unloading Valve

IS12

Manual override with push operation 12 V.

IS24

Manual override with push operation 24 V.

Data

Power consumption	14 W
Rated voltage	12 and 24 V
Max voltage variation	+/- 10 %
Duty factor	100 %
Connection	Hirschmann ISO 4400-DIN 43650
Protection class	IP65

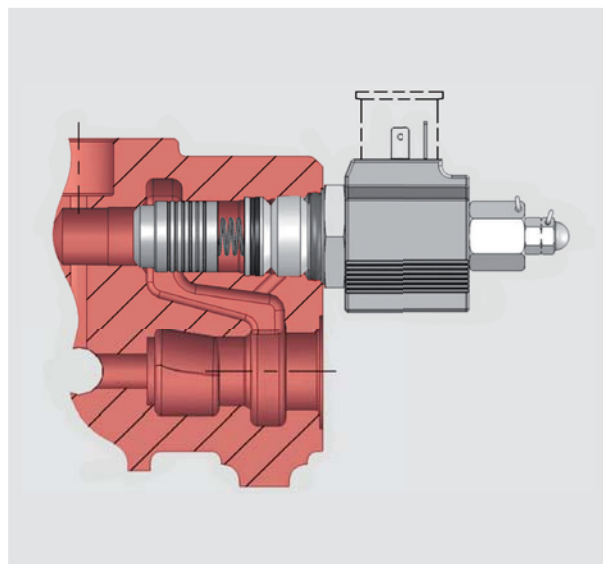

Spool controls – A-side

Spool control 9 9 Spring centered 9W for cable control	
Spool control 10 Detents at positions 1, 2 and 3	
Spool control 11 Spring centering with detent at position 4	
Spool control 13 Spring centering with detent at position 2	
Spool control 14 Spring centering with detent at position 3	
Spool control P Pneumatic*	
Spool control EP Electro / pneumatic on / off**	
Spool control P5 Pneumatic control with detent at position 4*	
Spool control EP5 Electro / pneumatic on / off with detent in position 4**	
Spool control MSLA Spool control, stroke limitation	

* Connection G 1/8" BSP

** Power consumption	4.8 W
Rated voltage	24 V
Max voltage variation	+/- 10 %
Duty factor	100 %
Connection	according to EN175301-803/B
Protection class	IP65

Spool controls – B-side

Bracket M19

Bracket for 3-position spool



Bracket M211

Bracket for 4-position spool and
for 4-pos EP-spool control

Bracket M212

Bracket for 4-position spool
with manual control

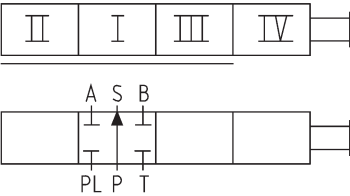
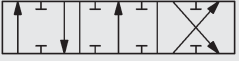
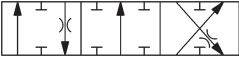
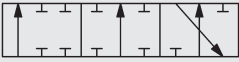
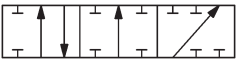
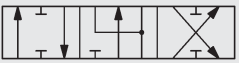
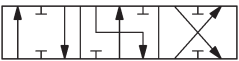
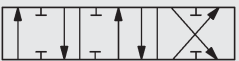
Spools

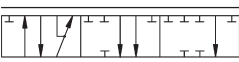
	Spools for general use Function	Code
	Double acting spool	10XAA1
	Slewing spool, gentle operating	10XKS1
	Single acting spool P – A	20XAA1
	Single acting spool P – B	20XAA2
	Motor spool	40XAA1
	Motor spool A – T	50XAA2
	Motor spool B – T	60XAA1
	Double acting spool with 4th pos. for float	30XAA1
	Regenerative spool	80XAA1
	Single acting "SR" *185 lpm lowering flow	713TA1

The RM 270 light spools are available in a variety of flows and styles to accommodate most design requirements. Since the development of spools is a continuous process and all available spools are not described in this data sheet, contact HYDAC for advice on choosing spools in order to optimize your valve configuration.

Generally the spools are divided in 5 different flow ranges. In the table only the accessibility of different functions are shown. The letter indicating flow range is replaced with X, as some spool functions are available in several flow ranges.

- 3 = 20 – 40 lpm
- 4 = 30 – 50 lpm
- 5 = 40 – 60 lpm
- 7 = 50 – 90 lpm
- 12 = 90 – 120 lpm

High pressure carry-over

High pressure carry-over plug SG25

The type SG25 series nipple is used for series mounting of valve blocks when pipe or hose is used between the blocks.

For RM 270 light Super Rapid see page 10.

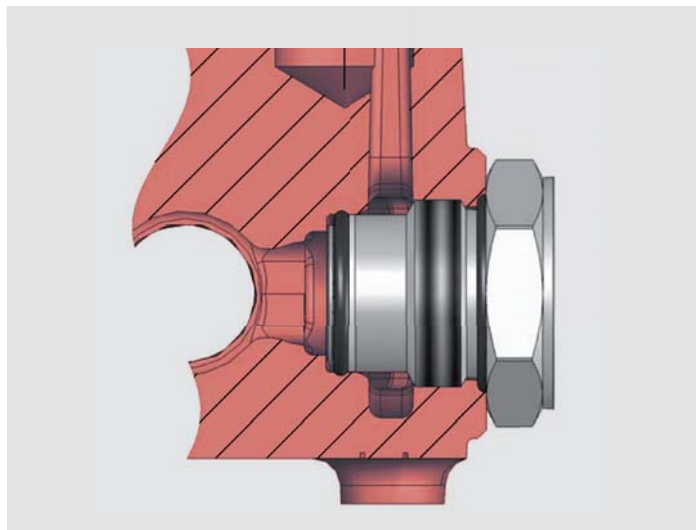

High pressure carry-over flange kit SC250

The type SC250 flange kit is used to connect valve blocks in series, without any pipe or hose.

For RM 270 light Super Rapid see page 10.

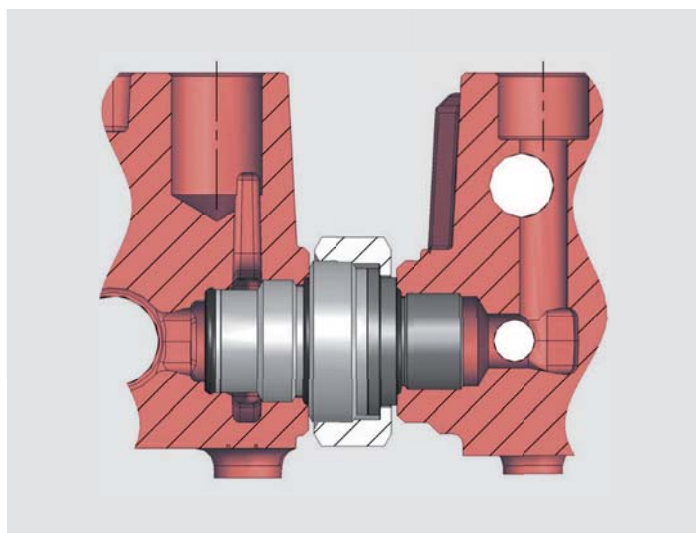

High pressure carry-over

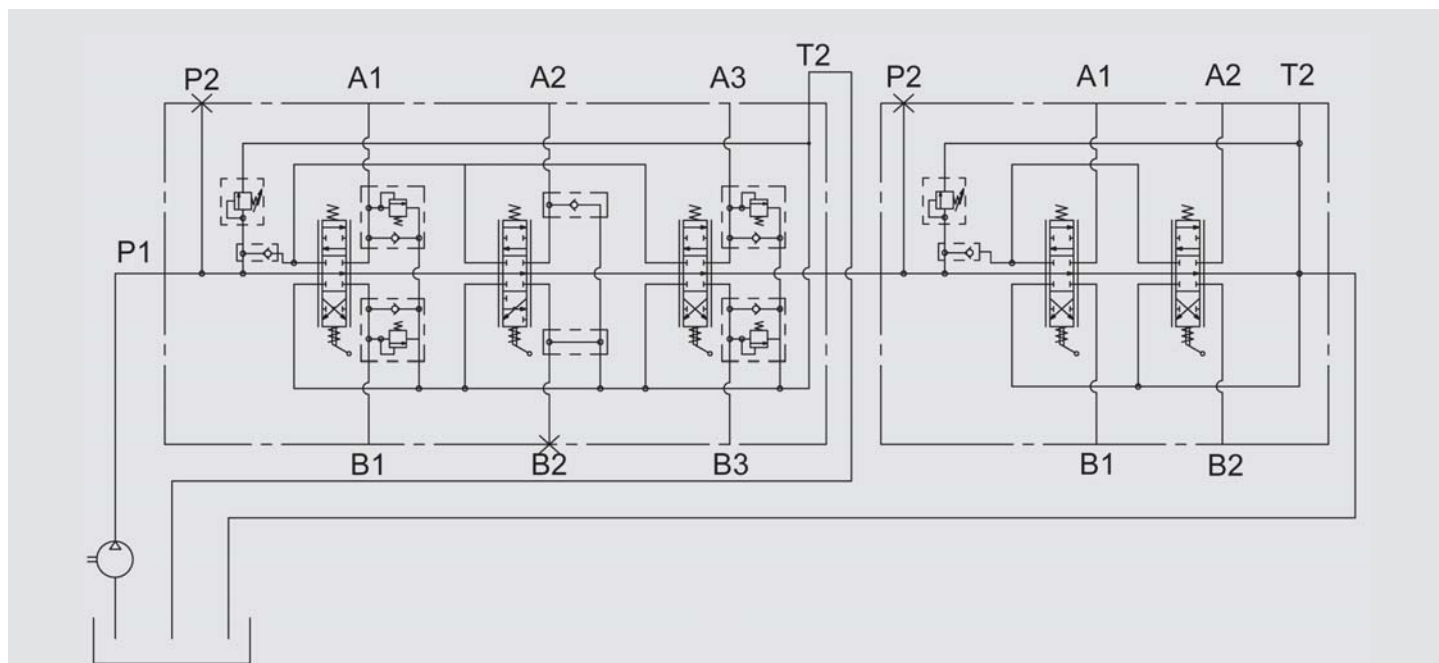

When high pressure carry over SG25 or SC250 is used for series mounting, the tank connection T2 for the first valve must always be connected to the tank (see diagram above). Valve blocks connected in series give priority of flow to the first block in the series. This means that there will be no flow at block 2 if block 1 is fully activated.

Preliminary Version

Integrated pressure carry-over function and extra check valve

The valve is made from a 1 section valve with a shuttle spool to create the pressure carry-over function, and an extra check valve in the pressure line. Carry-over pressure can be obtained from both A and B port, depending of which is used.

The built in shuttle spool makes it possible to use the return flow from, for instance, a hydraulic winch motor on a cable lift, to regulate the downward movement of the tipper cylinder at the same time as the winch pulls the platform on the frame.

The check valve prevents the oil from running backwards in the system when only the tipper valve is used.

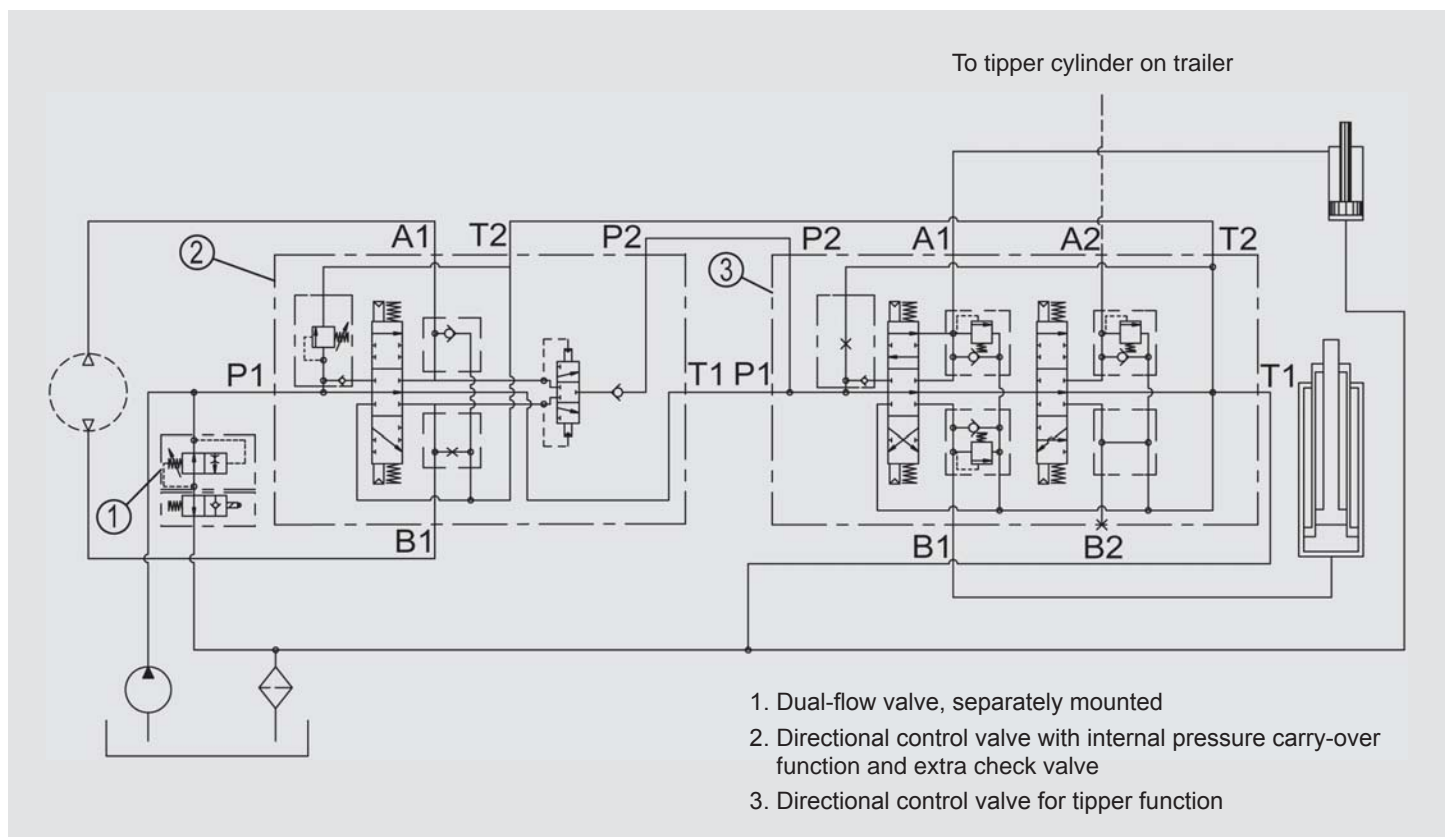
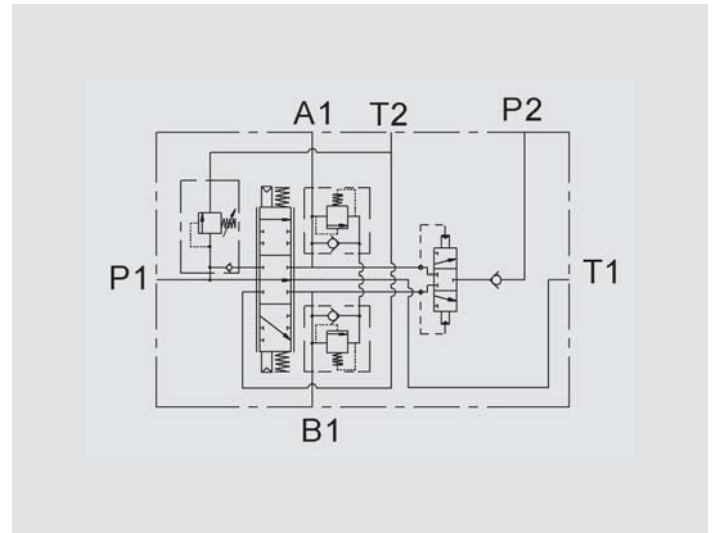

“Super Rapid” – tipping valve configuration

The “Super Rapid” tipping valve is optimized for maximum lowering flow. The multi section valves allows lowering at the same time as another function is pressurized. The valve can be equipped for variable pump operation. The valve is available with 1, 2 and 3 sections.

It is not possible to use a high pressure carry-over nipple SG25 or flange kit SC250 in a RM 270 light Super Rapid valve with only one section.

Each valve section can be provided with a pressure relief valve, an anticavitation valve or a combination of these.

The valve can be provided with pneumatic or electro/pneumatic spool control.

Technical data

Max. system pressure:	210 bar (21.0 MPa)
Max. return pressure:	20 bar (2.0 MPa)
Max. lowering flow:	185 l/min

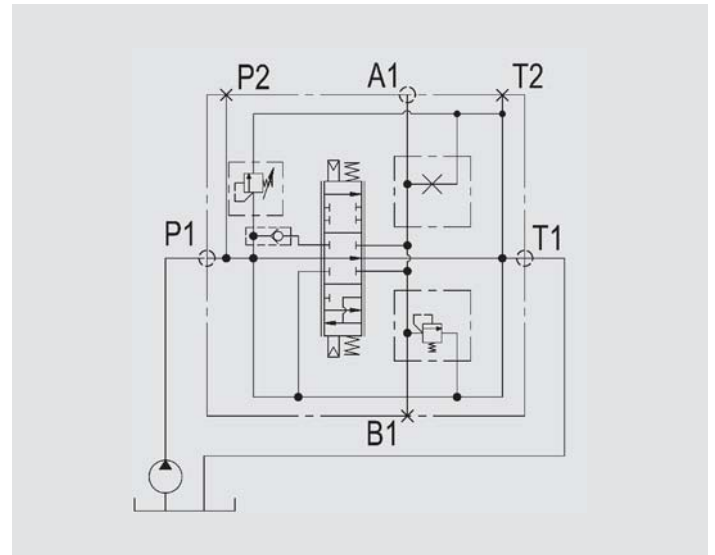

Typical configuration for refuse truck application

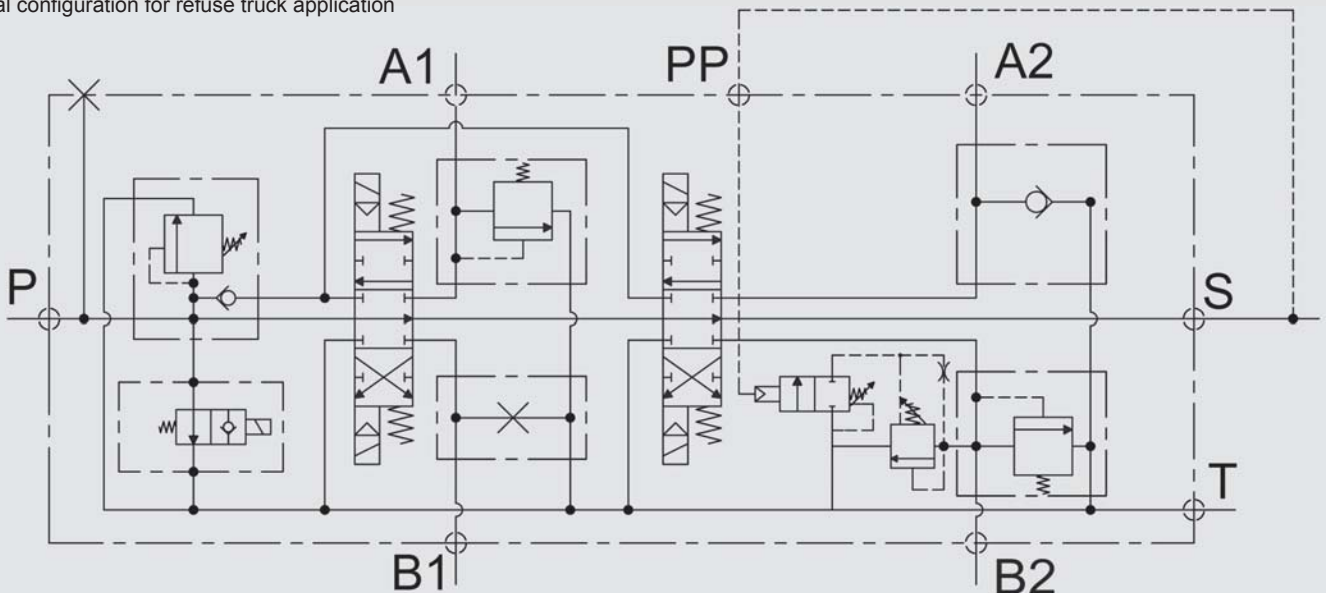

The valve can be configured for refuse vehicles. Typical is 1 four-sectional valve or 2 two-sectional valves for the functions tailgate, packing and exhaust. The pressure to the exhaust cylinder is controlled of the packing pressure so that the pressure is low during the packing cycle but high during exhaust. The circuit shows a two sectional valve with the functions tailgate on section 1 and exhaust on section 2. The valve for the packing functions is supplied from port S.

Note

The information in this brochure relates to the operating conditions and applications described.

For applications or operating conditions not described, please contact the relevant technical department. Subject to technical modifications.



Nordhydraulic
HYDAC INTERNATIONAL

Head Office
HYDAC INTERNATIONAL
GMBH

Industriegebiet
66380 Sulzbach/Saar
Germany

Phone: +49 6897 509-01
Fax: +49 6897 509-577

E-mail: mobilevalves@hydac.com
Internet: www.hydac.com