

Check Valve Poppet Type Direct Acting SAE-12 Cartridge – 350 bar RV12A-01

FUNCTION

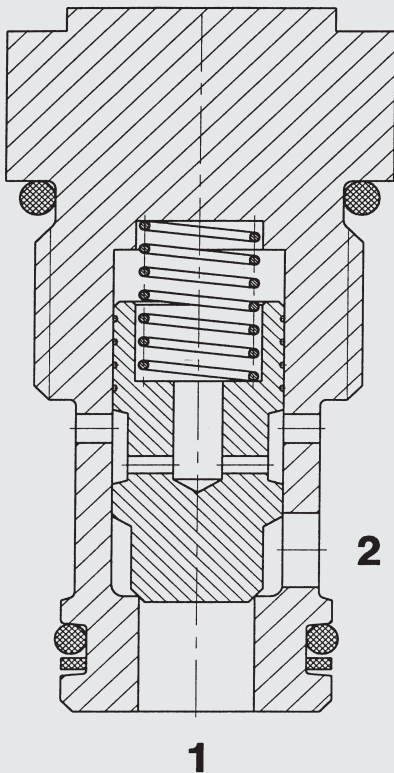

The check valve RV12A-01 is a direct acting cone poppet type valve which allows flow in one direction and shuts off flow in the opposite direction. When there is no flow through the valve, the spring holds the poppet in the closed position and therefore shuts off port 2 from port 1. The valve opens when the pressure at port 1 is higher than the pressure at port 2, including the pressure created by the spring force.

FEATURES

- External surfaces zinc-nickel plated and corrosion-proof
- Load is held in position leak-free
- Compact design
- Hardened and ground valve components to ensure minimal wear and extended service life

SPECIFICATIONS

Operating pressure:	max. 350 bar
Nominal flow:	max. 120 l/min
Internal leakage:	max. 0.1 cm ³ /min at 350 bar
Cracking pressure:	0.35 bar 0.80 bar 1.70 bar 3.40 bar
Media operating temperature range:	min. -30 °C to max. +100 °C
Ambient temperature range	min. -30 °C to max. +100 °C
Operating fluid:	Hydraulic oil to DIN 51524 Part 1 and 2
Viscosity range:	min. 7.4 mm ² /s to max. 420 mm ² /s
Filtration:	Class 21/19/16 according to ISO 4406 or cleaner
MTTF _d :	150 years*
Installation:	No orientation restrictions
Materials:	Valve body: free-cutting steel Poppet: hardened and ground steel Seals: NBR (standard) FKM (optional, media temperature range -20 °C to +120 °C)
Cavity:	FC12-2
Weight:	0.2 kg

* see "Conditions and instructions for valves" in brochure 5.300

DIMENSIONS

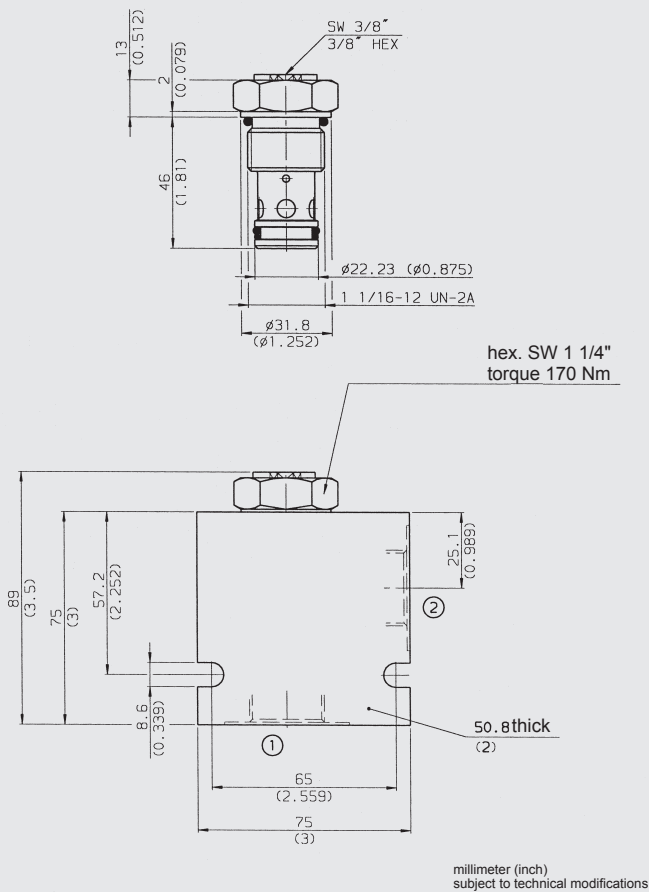

MODEL CODE

RV12A-01 - C - N - 05

Basic model

Check valve UNF

Body and ports*

C = cartridge only

SB6 = G3/4 ports, steel body

AB6 = G3/4 ports, aluminium body

Seals

N = NBR

V = FKM

Cracking pressure

05 = 0.35 bar (5 PSI)

12 = 0.80 bar (12 PSI)

25 = 1.70 bar (25 PSI)

50 = 3.40 bar (50 PSI)

Standard models

Model code	Part No.
RV12A-01-C-N-05	3047039
RV12A-01-C-N-12	3047040
RV12A-01-C-N-25	3047041
RV12A-01-C-N-50	3047042

*Standard in-line bodies

Code	Part No.	Material	Ports	Pressure
FH122-SB6	3053782	Steel, zinc-plated	G3/4	420 bar
FH122-AB6	3053843	Aluminium, anodized	G3/4	210 bar

Seal kits

Code	Material	Part No.
FH122-N Seal kit	NBR	3071298
FH122-V Seal kit	FKM	3071299

CAVITY

FC12-2

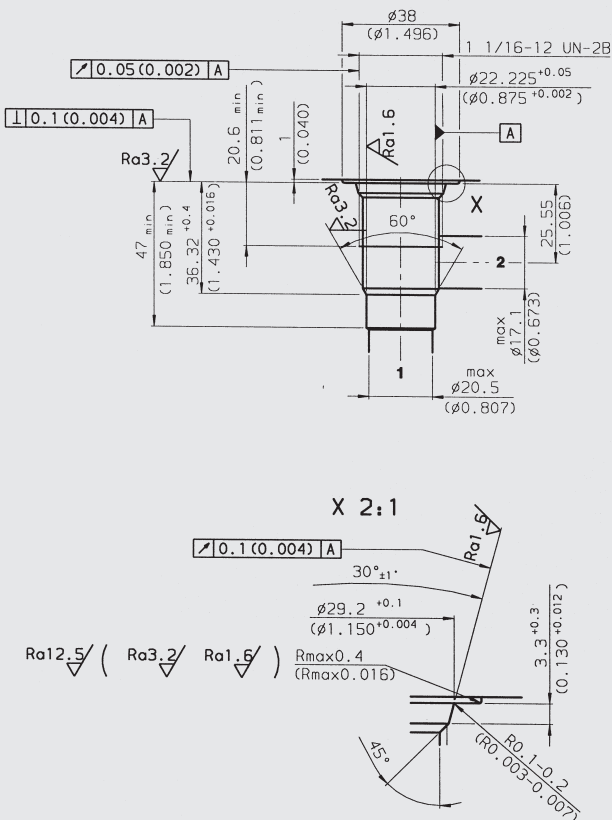

Form tools

Tool	Part No.
Countersink FC12-2	176951
Reamer FC12-2	176952

millimeter (inch) subject to technical modifications

PERFORMANCE

Measured at $v = 34 \text{ mm}^2/\text{s}$, $T_{\text{oil}} = 46 \text{ }^\circ\text{C}$

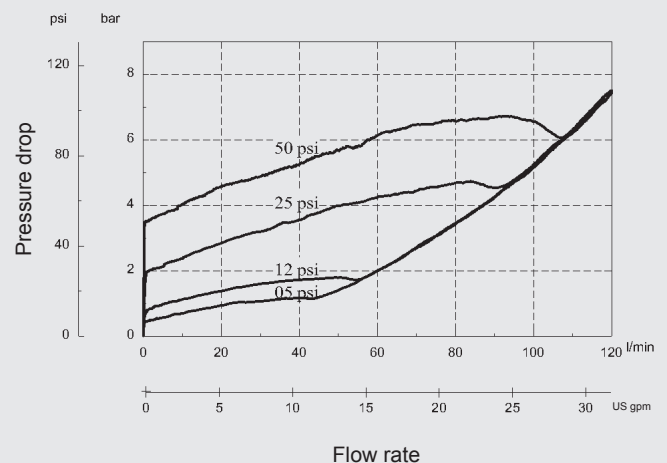

NOTE

The information in this brochure relates to the operating conditions and applications described. For applications or operating conditions not described, please contact the relevant technical department.
Subject to technical modifications.

HYDAC Fluidtechnik GmbH

Justus-von-Liebig-Str.
D-66280 Sulzbach/Saar
Tel: 0 68 97 /509-01
Fax: 0 68 97 /509-598
E-Mail: flutec@hydac.com