

**HYDAC**

**INTERNATIONAL**

**Quick release  
couplings**

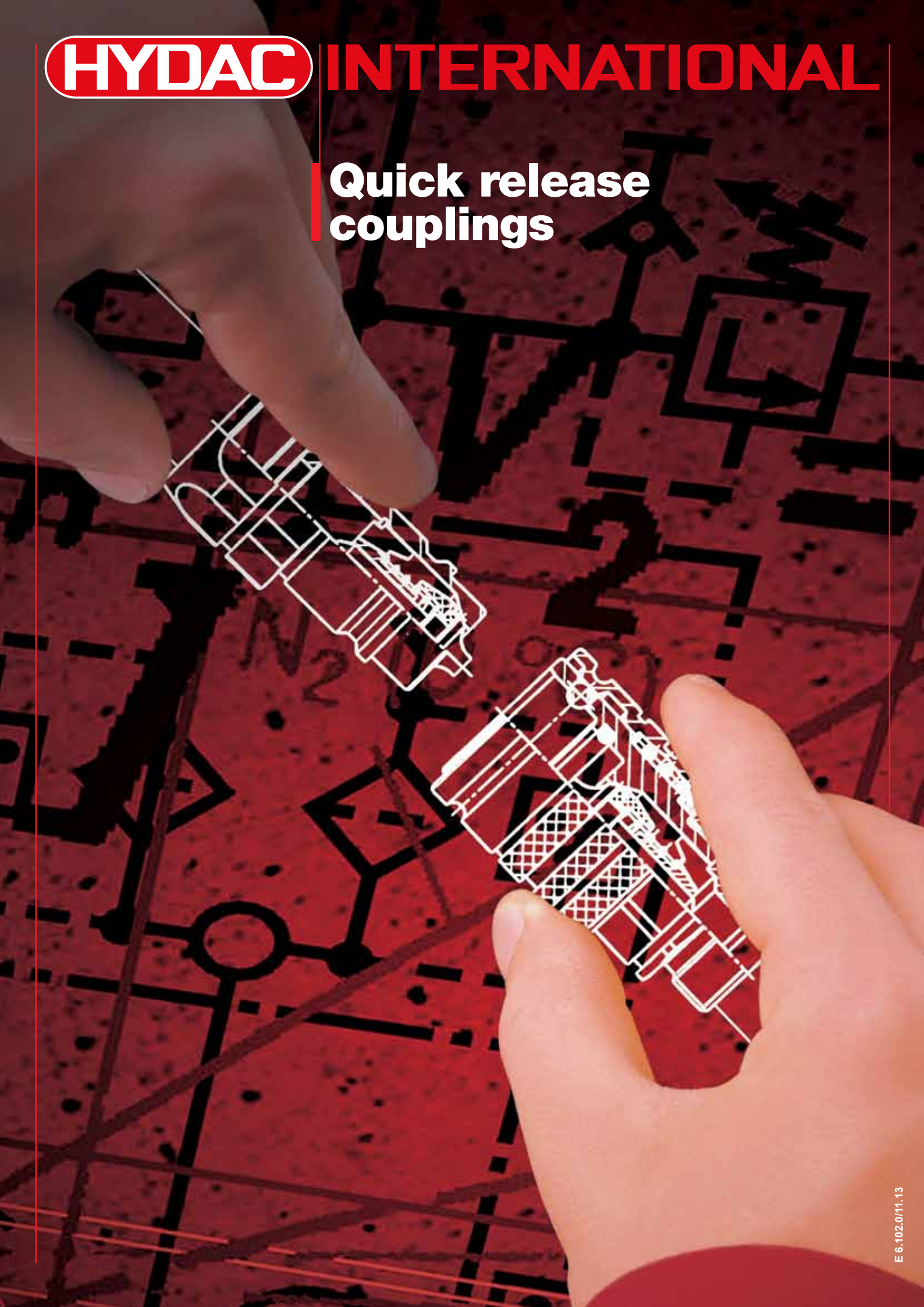

# Introduction

HYDAC couplings have proved their worth over many years of practical use in hydraulics. The high quality of the couplings is the result of constantly improving the products, while also taking account of users' experience. Their high manufacturing standard, combined with quality management to EN ISO 9001, guarantees the quality of our products.

The following characteristics apply to the couplings in our catalogue.

## Housing material:

Steel corresponding to EN 10277, zinc-plated

## Seals:

NBR/PTFE

## Operating temperature:

-30 °C to +100 °C

## Other applicable standards:

EN ISO 8330:2000, ISO 5675, ISO 5676, ISO 7241, ISO/DIS 16028

Please enquire about other material combinations.

Our range includes:

- Push fit couplings to ISO 7241-1, series A
- Push fit couplings, flat face, to ISO/DIS 16028
- Push fit couplings in plastic
- Locking couplings for hydraulic braking systems to ISO 5676
- Screw couplings
- Screw couplings for high pressures
- Pipe couplings

We are showing you a selection of these in this catalogue.

The operating pressures given in our catalogue relate to the strength of the housing components. Standardised connector shapes can have other nominal pressures, which do not have to apply to the type of coupling concerned.

Special agreements are possible.

It is not possible to make a general statement about the compatibility of our couplings to bio-oils. It can however be presumed that the compatibility will be the same as for rubber hoses.

A test will be required to make a definite statement in each case. Apart from the standard couplings, custom versions can also be supplied.

If you have a particular problem to solve, please get in touch with us.

As part of our process of continuous improvement, we reserve the right to make technical changes.

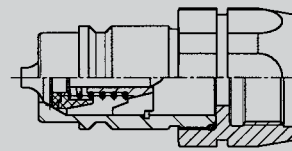
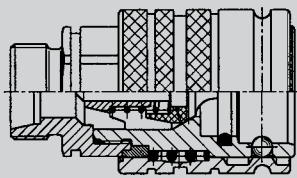

Push fit coupling ISO7241

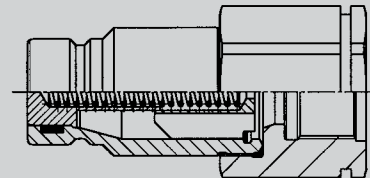
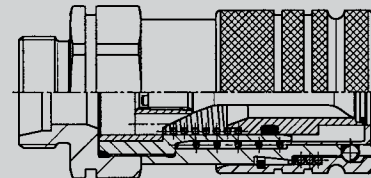

Push fit coupling ISO16028, with gasket

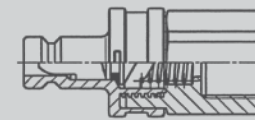
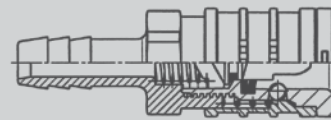

Push fit coupling, plastic

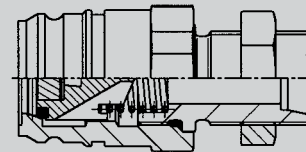
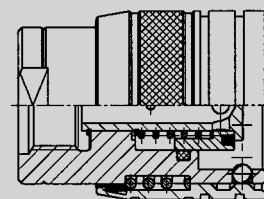

Locking couplings for hydraulic braking systems

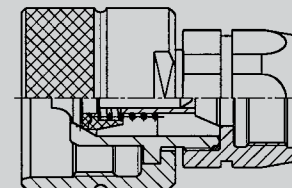
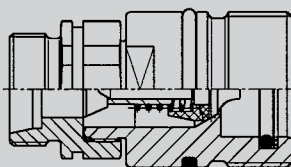

Screw coupling

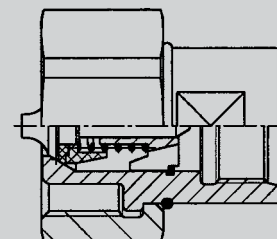
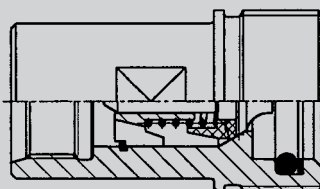

Screw coupling for high pressure

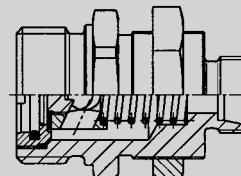
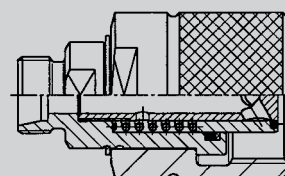

Pipe coupling

## Push fit couplings

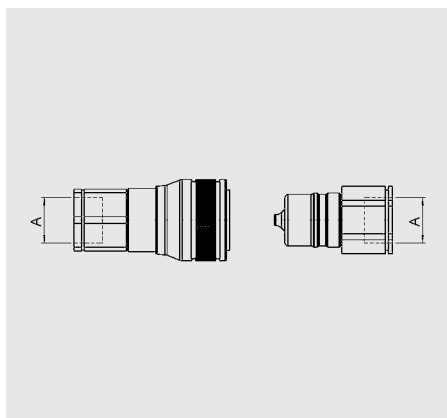

### Selection of available push fit couplings

	Connection A	Pipe Ø	P <sub>max</sub> [bar]	Size according to ISO 7241-1, series A				
				6.3	10	12.5	20	25
Female thread DIN 3852	G $\frac{1}{4}$	-	250	x	x			
	G $\frac{3}{8}$	-	250		x	x		
	G $\frac{1}{2}$	-	250			x		
	G $\frac{3}{4}$	-	250				x	x
	G1	-	250					x
	M16x1.5	-	250		x	x		
	M18x1.5	-	250			x		
	M22x1.5	-	250			x	x	
	NPTF $\frac{1}{4}$ -18	-	250	x				
	NPTF $\frac{3}{8}$ -18	-	250		x	x		
	NPTF $\frac{1}{2}$ -14	-	250					x
NPTF $\frac{3}{4}$ -14	-	250						x
NPTF 1-11 $\frac{1}{2}$	-	250						x
UNF $\frac{3}{4}$ -16	-	250				x		
Male stud with type W bore (24") DIN 3861	M14x1.5	8L	250	x	x	x		
	M16x1.5	10L	250		x	x		
	M18x1.5	12L	250		x	x	x	
	M22x1.5	15L	250			x	x	
	M26x1.5	18L	250			x	x	x
	M30x2	22L	250				x	x
	M36x2	28L	250					x
	M45x2	35L	250					x
	M16x1.5	8S	250		x			
	M18x1.5	10S	250		x	x		
	M20x1.5	12S	250		x	x		
	M22x1.5	14S	250			x		
	M24x1.5	16S	250			x	x	
	M30x2	20S	250				x	x
	M36x2	25S	250					x
M42x2	30S	250					x	
Male stud with type W bore (24") DIN 3861 Bulkhead	M12x1.5	6L	250		x			
	M14x1.5	8L	250	x	x	x		
	M16x1.5	10L	250		x	x		
	M18x1.5	12L	250		x	x	x	
	M22x1.5	15L	250			x	x	
	M26x1.5	18L	250			x	x	x
	M30x2	22L	250				x	x
	M36x2	28L	250					x
	M16x1.5	8S	250		x			
	M18x1.5	10S	250		x	x		
	M20x1.5	12S	250		x	x		
	M22x1.5	14S	250			x		
	M24x1.5	16S	250			x	x	
	M30x2	20S	250				x	x
	M36x2	25S	250					x
M42x2	30S	250					x	
Male thread DIN 3852	G $\frac{3}{8}$	-	250		x	x		
	G $\frac{1}{2}$	-	250			x		
	M22x1.5	-	250			x		

### Order data

- Nominal size
- Pipe Ø
- Threaded connection
- Size
- Operating pressure
- Material

Apart from the standard couplings, custom versions can also be supplied. Contact us for more information.

## Description

HYDAC offers a wide range of products for agricultural machinery as well as for hydraulic systems in vehicles and construction machines. Thanks to their modular design, a large variety of connections is available, which conform to international standards.

## Technical Data

Dimensions	According to ISO 7241-1, series A, as well as ISO 5675		
Housing material	Steel corresponding to EN 10277		
Material of seals	NBR / PTFE ISO 3601		
Operating pressure	$P_{max}$	250 bar	With standard threaded connections, the operating pressure is governed by the highest rated pressure of the connection.
Burst pressure	$P_{coupled}$ $P_{female}$ $P_{male}$	1000 bar 1000 bar 1000 bar (except size 25 → here max. 700 bar)	
Ports	Male thread DIN 3852 Female thread DIN 3852 Male stud with type W bore (24°) to DIN 3861 Male stud with type W bore (24°) to DIN 3861, bulkhead		
Operating temperature	-30 °C to +100 °C		

## NOTE

The information in this brochure relates to the operating conditions and applications described.

For applications and operating conditions not described, please contact the relevant technical department.

Subject to technical modifications.

## Accessories

### Dust protection parts

These dust caps and dust plugs can be retrofitted to the connectors.

Colour: red

**HYDAC Accessories GmbH**  
Hirschbachstr. 2  
**66280 Sulzbach/Saar**  
Tel.: +49 (0)6897 - 509-01  
Fax: +49 (0)6897 - 509-1009  
Internet: [www.hydac.com](http://www.hydac.com)  
E-Mail: [info@hydac.com](mailto:info@hydac.com)

## Push fit couplings, flat face

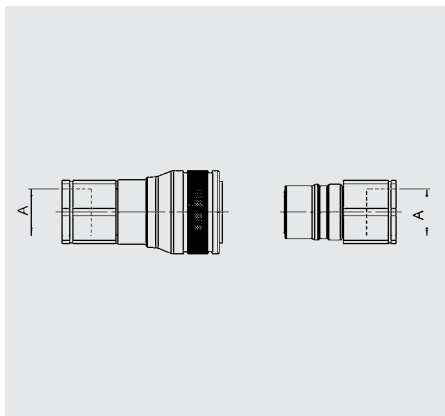

### Selection of available push fit couplings

	Connection A	Pipe Ø	P <sub>max</sub> [bar]	Size according to ISO 16028					
				6.3	10	12	16	19	25
Female thread DIN 3852	G $\frac{1}{4}$	-	400	x					
	G $\frac{3}{8}$	-	350		x				
	G $\frac{1}{2}$	-	350		x	x			
	G $\frac{3}{4}$	-	350			x	x	x	
	G1	-	350					x	
	G1 $\frac{1}{4}$	-	350 / 300**					x	x
	G1 $\frac{1}{2}$	-	300						x
	M22x1.5	-	350		x				
	NPTF $\frac{1}{4}$ -18	-	400	x					
	NPTF $\frac{3}{8}$ -18	-	350		x				
	NPTF $\frac{1}{2}$ -14	-	350		x				
	NPTF $\frac{3}{4}$ -14	-	350			x			
	NPTF $\frac{3}{4}$ -16	-	350				x		
	NPTF 1-11 $\frac{1}{2}$	-	350					x	
	NPTF 1 $\frac{1}{2}$ -11 $\frac{1}{2}$	-	300						x
	UNF 9/16-18	-	400	x					
	UNF $\frac{3}{4}$ -16	-	350		x				
	UNF 7/8-14	-	350			x			
UNF 11/16-12	-	350				x	x	x	
UNF 15/16-12	-	350						x	
UNF 15/8-12	-	300						x	
Male stud with type W bore (24") DIN 3861	M14x1.5	8L	400	x					
	M16x1.5	10L	400* / 350	x	x				
	M18x1.5	12L	350		x	x			
	M22x1.5	15L	350		x	x	x		
	M26x1.5	18L	350			x	x	x	
	M30x2	22L	350				x	x	
	M36x2	28L	350					x	
	M16x1.5	8S	400	x					
	M18x1.5	10S	400	x					
	M20x1.5	12S	350		x				
	M24x1.5	16S	350		x	x	x		
	M30x2	20S	350			x	x	x	
	M36x2	25S	350				x	x	
	M42x2	30S	350						x
Male stud with type W bore (24") DIN 3861 Bulkhead	M14x1.5	8L	400	x					
	M16x1.5	10L	400* / 350	x	x				
	M18x1.5	12L	350		x	x			
	M22x1.5	15L	350		x	x	x		
	M26x1.5	18L	350			x	x	x	
	M30x2	22L	350				x	x	
	M36x2	28L	350					x	
	M16x1.5	8S	400	x					
	M18x1.5	10S	400	x					
	M20x1.5	12S	350		x				
	M24x1.5	16S	350		x	x	x		
	M30x2	20S	350			x	x	x	
	M36x2	25S	350				x	x	
	M42x2	30S	350						x
M36x2	25S	250						x	
M42x2	30S	250						x	

### Order data

- Nominal size
- Pipe Ø
- Threaded connection
- Size
- Operating pressure
- Material

Apart from the standard couplings, custom versions can also be supplied. Contact us for more information.

\* for size 6.3  
\*\* for size 25

## Description

During coupling and releasing, the design of the flat face push fit couplings ensures minimal oil loss and minimal air incursion. Due to the fixed valve tappet in the coupling, backflow is effectively prevented.

The couplings are also designed for easy cleaning and to keep dirt out.

Their main applications are for machines which work in environmentally sensitive areas and hydraulic tools. Thanks to their modular design, HYDAC can make a large variety of connections available which conform to international standards.

## Technical Data

Dimensions	to ISO/DIS 16028							
Housing material	Steel corresponding to EN 10277							
Material of seals	NBR / PTFE ISO 3601							
Operating pressure	P <sub>max</sub>	Up to 400 bar (see table)						
		With standard threaded connections, the operating pressure is governed by the highest rated pressure of the connection.						
Burst pressure [bar]	Size	6.3	10	12	16	19	25	
	P <sub>coupled</sub>	2000	1500	1500	1200	1450	800	
	P <sub>female</sub>	1220	1100	1050	1200	1050	800	
	P <sub>male</sub>	1850	1100	1050	1100	1050	800	
Ports	Female thread DIN 3852 Male stud with type W bore (24°) to DIN 3861 Male stud with type W bore (24°) to DIN 3861, bulkhead							
Operating temperature	-30 °C to +100 °C							

## NOTE

The information in this brochure relates to the operating conditions and applications described.

For applications and operating conditions not described, please contact the relevant technical department.

Subject to technical modifications.

## Accessories

### Dust protection parts

- Dust cap for connector (male)
- Dust cap for connector (female)

**HYDAC Accessories GmbH**  
Hirschbachstr. 2  
**66280 Sulzbach/Saar**  
Tel.: +49 (0)6897 - 509-01  
Fax: +49 (0)6897 - 509-1009  
Internet: [www.hydac.com](http://www.hydac.com)  
E-Mail: [info@hydac.com](mailto:info@hydac.com)

# Spare Parts

- O-ring material: NBR
- Back-up ring material: PTFE
- Brake ring material: NBR
- Valve seal material: NBR
- Lock nut material: steel, zinc-plated

Dimensions according to the size concerned

## Overview of couplings

Designation Function	Size	DN [Inch]	A <sub>min</sub> [mm <sup>2</sup> ]	Q <sub>max</sub> [mm <sup>2</sup> ]	Operating pressure [bar]	Burst pressure			Leakage oil [ml]
						coupled [bar]	Sleeve [bar]	Connector [bar]	
<b>Push fit coupling</b> Corresponds to ISO 7241-1, series A	6.3	¼	24	20	250	1000	1000	1000	0.8
	10	⅜	45	40	250	1000	1000	1000	1.2
	12.5	½	76	80	250	1000	1000	1000	1.7
	20	¾	130	120	250	1000	1000	700	8
	25	1	256	160	250	1000	1000	700	12
<b>Flat face couplings</b> Corresponds to ISO 16028	6.3	¼	29	40	400	2000	1220	1850	0.01
	10	⅜	63	80	350	1500	1100	1100	0.015
	12	½	147	120	350	1500	1050	1050	0.02
	16	¾	127	140	350	1200	1200	1100	0.02
	19	1	156	180	350	1450	1050	1050	0.032
	25	1 ¼	251	260	300	800	800	800	0.03
can be coupled under pressure	10	⅜	63	80	350	1700		1500	0.015
	12	½	147	120	350	1500		1400	0.02
	19	1	156	180	350	1600		1600	0.032
<b>Brake line couplings</b> Low-leakage gasket corresponding to ISO5676	12.5	½		70	150	315	75	150	
<b>Screw couplings</b> Can be coupled under pressure with/without a tool	6.3	¼	24	20	450	1800	1400	1400	
	10	⅜	45	40	450	1600	1750	1550	
	12.5	½	76	80	400	1400	1200	1200	
	19	¾	130	120	400	1500	1600	1200	
	25	1	256	160	300	1180	1500	1100	
	32	1 ¼	660	220	300	1800	1600	1200	
<b>Screw coupling</b> For high pressure	12.5	½	76	80	350/465*	2000	1850	1750	
	16	¾	256	160	350/465*	1800	2000	1750	
<b>Screw coupling</b> Flat face screw coupling	10	⅜	63	80	550	1800	1000	1400	
	12	½	147	120	550	1700	1000	1300	
	19	1	156	180	550	1400	1000	1400	
<b>Pipeline coupling</b> Flat face screw coupling	10	⅜	55	40	420	1800	1680	1200	
	12.5	½	105	70	420	1600	1600	900	
	19	¾	160	105	320	1150	1280	1280	
	20	1	285	120	350	1200	1250	700	
	32	1 ¼	620	250	420	1150	1100	900	
<b>Screw coupling</b> For hammer operation	12	½	130	160	400	1500	1200	1200	
	20	¾	130	180	400	1500	1200	1200	
	32	1 ¼	467	660	380	1520	1520	1520	
<b>Plastic coupling</b> Also without valve	6.3	¼	26.4	20	20	80	60	80	

\* Static pressure

# Determining the coupling size

Nomographic chart to determine the coupling size

**Q** = Flow rate

**A** = Cross-section of the coupling

**V** = Oil velocity

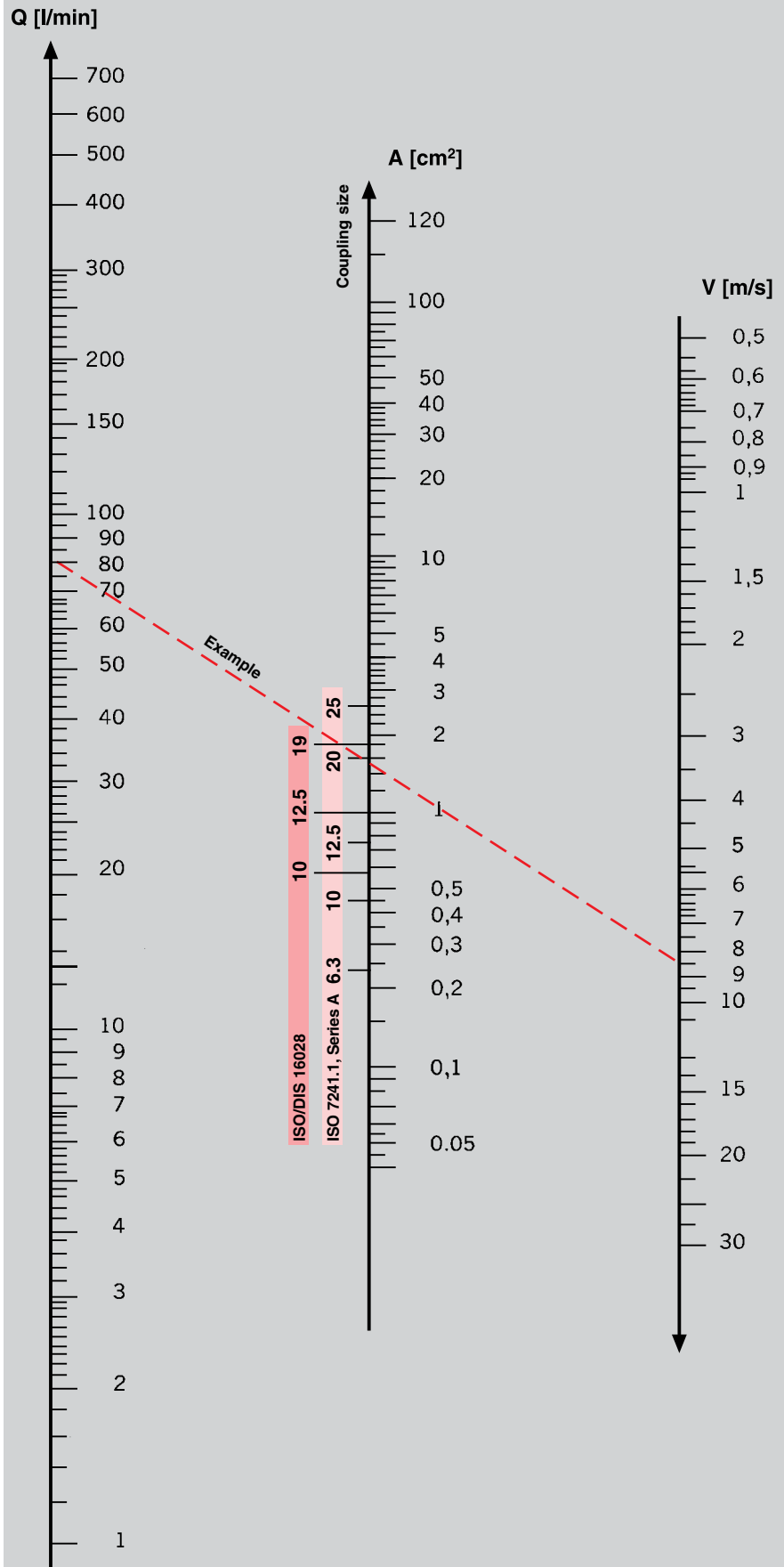



# Safety precautions for the handling of quick release couplings and the corresponding accessories

## Important !

Incorrect selection or incorrect and inexperienced handling of couplings and accessories can lead to material damage and personal injury.

- Escape of hydraulic fluids under high pressure
- Explosion or ignition of the fluid used
- Collision with parts starting to move or fall, caused by the failure of the hydraulic circuit
- Dangerous lashing of the hydraulic hoses (so-called whipping effect)
- Risk of injury due to contact with hot or cold fluids or fluids which are dangerous for other reasons

Before you select and use a quick release coupling or the corresponding accessories, it is vital that you comply with the following instructions.

## 1. General information

### 1.1 General

This section contains instructions on the choice and handling (installation, coupling and disconnecting procedure and maintenance). This is to be understood as additional safety information and must be considered when using the products.

### 1.2 Safety precautions

Under certain circumstances, couplings can unexpectedly fail. Take account of this when planning your system or plant, using safety devices.

### 1.3 Information for the user

Pass these safety instructions on to the persons who are responsible for the selection or handling. Only use the couplings after you have received and understood the product-specific information.

### 1.4 The user's responsibility

Owing to the large variety of applications for quick release couplings, it is not possible to consider every application and each technical detail.

The user is responsible for

- The final selection of the product
- The operator's compliance with the requirements
- The safety of persons and plant
- The safety precautions which are necessary when using couplings

Should you have any other questions, please contact our sales team.

## 2. Notes for the correct choice of coupling

### 2.1 Pressure range

The couplings must be chosen so that their maximum permissible operating pressure is greater than or equal to the system pressure. Pressure peaks in the system, which exceed the operating pressure will reduce the coupling's service life and must thus be considered when making the selection.

### 2.2 Media resistance

The sealing materials in the locking couplings are suitable for numerous pressurised media.

Your product manager will supply you with information about compatibility with a fluid on request.

### 2.3 Working temperature

The working temperatures in the specifications are maximum values. These values must not be exceeded with a stationary or a circulating circuit. During actuation, the natural heating of the coupling must be considered.

### 2.4 Size

The choice of size and type of connection depends upon the required level of power transmission. The corresponding diagrams are to be used for this.

Flow rates, pressure drops and flow speeds must be considered when choosing the correct size.

If these values are exceeded during operation, faults may occur in the function of the coupling.

### 2.5 Mechanical connection

The connection of two halves of a coupling depends on the model. Here care should be taken that push-fit couplings completely engage and that screw-fit couplings are fully screwed on, until the stop is reached. Forcefully and improperly undoing locking couplings will lead to faults.

### 2.6 Thermal loading

Strongly heating above the recommended operating temperature, by welding or soldering on the couplings, can produce hazardous gases. Apart from that, the surface protection (zinc plating) can be damaged. This can interfere with proper functioning.

### 2.7 Guidelines

All of the specifications and standards applicable for the area of application must be complied with when making a choice.

## Technical information

		Flange		Metric						
Size	DN	3000 psi	6000 psi	Light range	Heavy range	Inch	BSP	JIC	ORS	NPTF
03	05			M12x1.5-6	M16x1.5-8	1/16	G1/8"	3/8-24		1/8-27
04	06			M14x1.5-8	M18x1.5-10	1/4	G1/4"	7/16-20	9/16-18	1/4-18
05	08			M16x1.5-10	M20x1.5-12	5/16		1/2-20		
06	10			M18x1.5-12	M22x1.5-14	3/8	G3/8"	9/16-18	11/16-16	3/8-18
08	12	1/2"	1/2"	M22x1.5-15	M24x1.5-16	1/2	G1/2"	3/4-16	13/16-16	1/2-14
10	16			M26x1.5-18	M30x2-20	5/8	G5/8"	7/8-14	1-14	
12	20	3/4"	3/4"	M30x2-20	M36x2-25	3/4	G3/4"	1 3/16-12	1 3/16-12	3/4-14
16	25	1"	1"	M36x2-25	M42x2-30	1	G1"	1 5/16-12	1 7/16-12	1-11.5
20	32	1 1/4"	1 1/4"	M45x2-35	M52x2-38	1 1/4	G1 1/4"	1 5/8-12		1 1/4-11.5
24	40	1 1/2"	1 1/2"	M52x2-42		1 1/2	G1 1/2"	1 7/8-12		1 1/2-11.5
32	50	2"	2"			2	G2	2 1/2-12		2-11.5
40	65	2 1/2"				2 1/2		3-12		
48	80	3"				3		3 1/2-12		
56	90	3 1/2"				3 1/2				
64	100	4"				4				

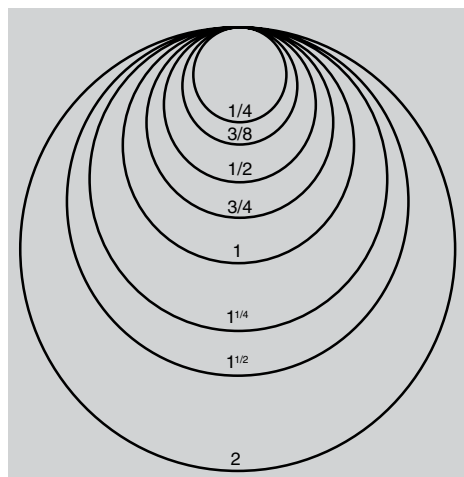

### American threaded connections (NPTF and NPSM)

To determine the nominal size of the NPTF thread, hold the end of the thread against the matching circle.

### NOTE

The information in this brochure relates to the operating conditions and applications described.

For applications and operating conditions not described, please contact the relevant technical department.

Subject to technical modifications.

**HYDAC Accessories GmbH**  
Hirschbachstr. 2  
**66280 Sulzbach/Saar**  
Tel.: +49 (0)6897 - 509-01  
Fax: +49 (0)6897 - 509-1009  
Internet: [www.hydac.com](http://www.hydac.com)  
E-Mail: [info@hydac.com](mailto:info@hydac.com)