

Backflushing Filter AutoFilt® RF7



RF7 - 1

RF7 - 2.5

RF7 - 4

RF7 - 6

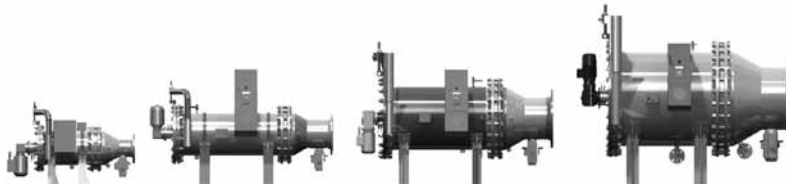

1. TECHNICAL SPECIFICATIONS

1.1 GENERAL

The AutoFilt® RF7 is a self cleaning system for extracting particles from low viscosity fluids. Its robust construction and automatic backflushing capability make a major contribution to operational reliability and **reduce operating and maintenance costs**. The slotted tube or SuperMesh elements in the filter with **filtration rates from 25 to 3000 µm** ensure highly effective filtration of contaminating particles from the process medium. Automatic cleaning starts as soon as the elements become contaminated. **The flow of filtrate is not interrupted during the backflushing procedure.** A range of filters of different sizes allow **flow rates of up to 7500 m³ per hour.** Numerous combinations of materials and equipment as well as **individually adjustable control parameters** allow optimum adaptation of the filter to any application.

The new horizontal backflushing filter AutoFilt® RF7 supplements the Hydac backflushing filter family by a further, particularly user-friendly, compact series which is especially applicable for systems where there is little space.

The series pivoting lid device allows easy access to the inside of the filter without requiring a lot of force or time. A special holding device allows the filter elements to be removed if necessary without hoisting equipment being required. They can easily be reinstalled without damaging the filter elements or the housing wall.

1.2 OPERATION OF THE AUTOFILT® RF7

Filtration

The fluid to be filtered flows through the slotted tube filter elements of the backflushing filter, passing from the inside to the outside. Contamination particles then collect on the smooth inside of the filter elements. As the level of contamination increases, the differential pressure between the contaminated and clean sides of the filter increases. When the differential pressure reaches its pre set value, backflushing starts automatically.

Filtration

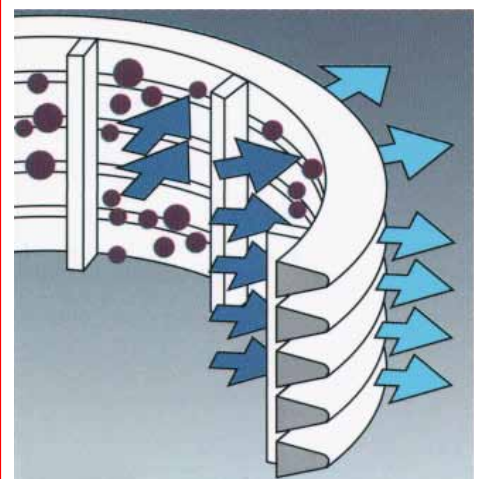
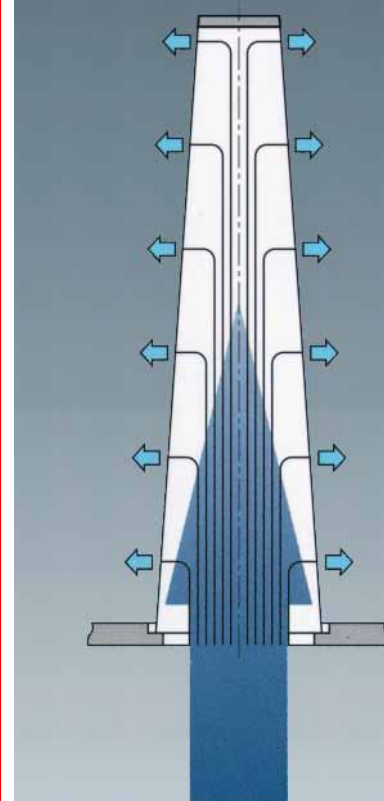

Triggering automatic backflushing

Automatic backflushing is triggered:

- When the triggering differential pressure is exceeded
- By means of an adjustable timer (optional)
- By pressing the TEST key

As soon as backflushing has been triggered, the filter starts to clean the filter elements.

Backflushing of the filter elements - backflushing cycle

The backflushing function depends on the selected control type:

- EPT: Electro-pneumatic cyclic control
The gear motor rotates the rinsing arm under the filter elements to be cleaned and stops. The backflushing valve is opened and this or the elements are cleaned due to the pressure drop between the filtrate side and the backflushing line. After the "backflushing time per element" has ended, the backflushing valve is closed. The gear motor then rotates the arm further to the next filter elements to be cleaned. The backflushing valve is opened again and the filter elements are backflushed. A complete backflushing cycle is complete once all filter elements have been cleaned.
- PT: Pneumatic cyclic control:
Like EPT, but with purely pneumatic components.
- PTZ: Pneumatic cyclic control with timer function
Like PT, but a maximum filtration time can be set, independent of the differential pressure, between two backflushing cycles.
- EU: Electrical circulation control
The electrical backflushing valve opens. The gear motor rotates the rinsing arm continually past and under the filter elements to be cleaned. The pressure drop between the filtrate side and the backflushing line rinses a small partial flow of the filtrate in the opposite direction into the filter elements to be cleaned. The contamination particles deposited on the inside of the filter elements are detached and carried out via the backflushing arm into the backflushing line. Once the rinsing arm has reached its position, the gear motor stops and the electrical backflushing valve closes automatically.
- EPU: Electro-pneumatic circulation control as EU but with pneumatic actuator on backflushing valve.

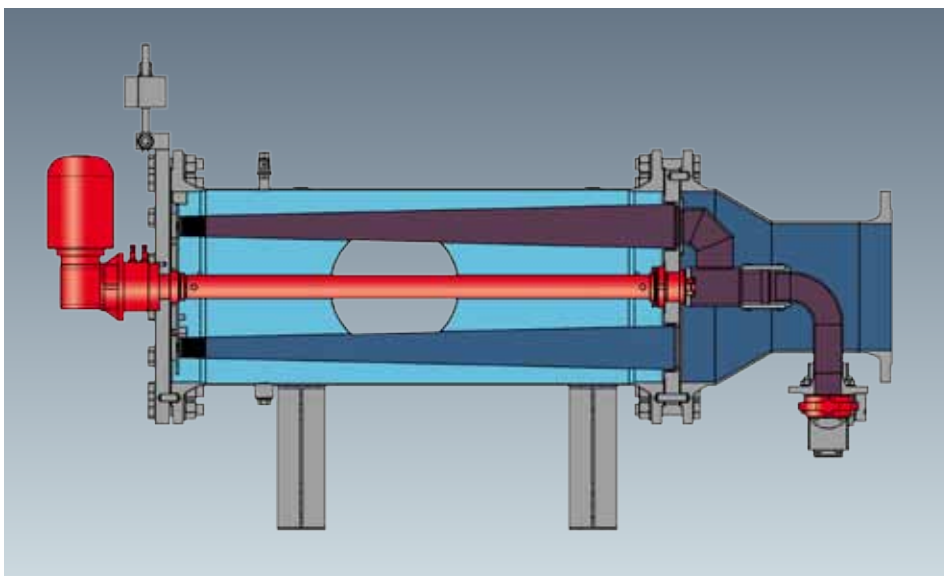
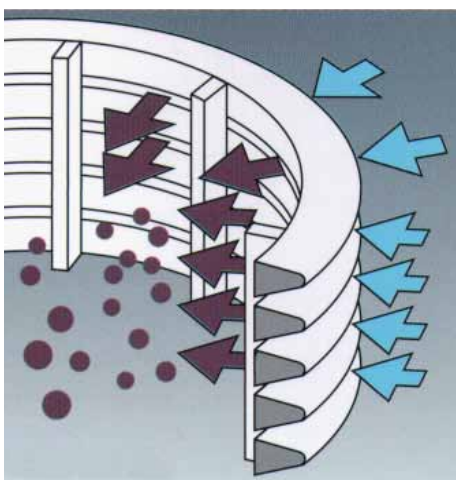
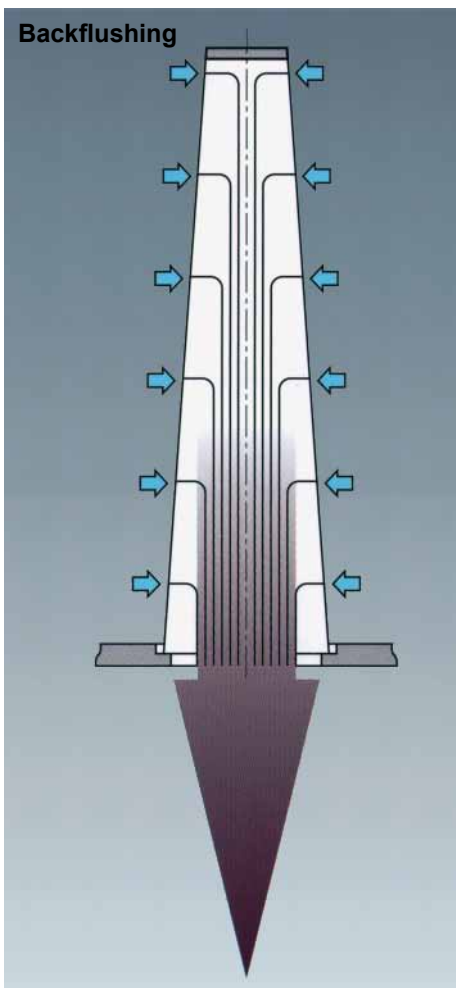

1.3 SPECIAL FEATURES OF THE AUTOFILT® RF7

Isokinetic filtration and backflushing

The patented conical shape and configuration of the filter elements allows even flow, resulting in low pressure drops and complete cleaning of the elements across the entire installed filter area. The advantage: fewer backflushing cycles and reduced loss of backflushing fluid.

Pulse aided backflushing

On the cyclic control types EPT and PT, the rinsing arm remains under each filter element for only a few seconds. Rapid opening of the pneumatic backflushing valve generates a pressure surge in the filter element openings, providing an additional cleaning effect to the backflushing process.

Small backflushing quantities due to cyclic control

The backflushing valve opens and closes during backflushing of each filter element.

2. FILTER SPECIFICATIONS

2.1. STANDARD CONFIGURATIONS

2.1.1 Control parameters

- EPT: electro-pneumatic cyclic control
- EU: electrical circulation control (electric only)
- PT: pneumatic cyclic control (pneumatic only)
- PTZ: pneumatic cyclic control with timer function (pneumatic only)
- EPU: electro-pneumatic circulation control

2.1.2 Connection voltages

- 3 x 400V / 50 Hz with or without neutral wire
- 3 x 500V / 50 Hz without neutral wire
- 3 x 230V / 50 Hz with or without neutral wire
- 3 x 415V / 50 Hz without neutral wire
- 3 x 415V / 60 Hz with neutral wire
- 3 x 460V / 60 Hz without neutral wire
- Others available on request

2.1.3 Flange connections

- DIN / ANSI / JIS

2.1.4 Housing materials

- Carbon steel
- Stainless steel

2.1.5 Material of internal parts

- Stainless steel 1.4301

2.1.6 Material of elements

- Stainless steel 1.4435, 1.4404

2.1.7 External corrosion protection

- 2-coat primer (not required for stainless steel housing)

2.1.8 Internal corrosion protection

- Epoxy coating
- Polyurethane coating
- Rubber lined

2.1.9 Differential pressure gauge

- Aluminium
- Stainless steel
- Brass
- Chemical seal

2.1.10 Filtration ratings

- 25 µm, 40 µm and 60 µm SuperMesh
- 50 µm to 3000 µm slotted tube

2.1.11 Electrical protection class

- IP55

2.1.12 Pressure ranges

- 10 bar or 6 bar depending on size

2.1.13 Operating temperature

- Max. operating temperature 90 °C

2.2. OPTIONAL VERSIONS

There are a range of optional versions available for the AutoFilt® RF7. For technical details and prices, please contact our Technical Sales Department at Head Office.

2.2.1 Control /electrical components / voltage supply

- PLC control
- Filter without control for integration into customer's PLC
- Filter interlocking for parallel operation
- UL/CSA approved controls and components
- Special IP protection classes
- Safe in tropical conditions
- Customised special solutions

2.2.2 Housing manufacture

- ASME Code Design
- U-Stamp

2.2.3 Flange connections

- ANSI
- JIS

2.2.4 Housing materials

- Duplex
- Superduplex
- Various qualities of stainless steel
- Various qualities of carbon steel

2.2.5 Materials of internal parts and elements

- Duplex
- Superduplex
- Various qualities of stainless steel
- Superflush element coating

2.2.6 External corrosion protection

- Multiple layer coatings
- Special paints / coatings for offshore use
- Special paint/coatings according to customer specifications
- Colours to customer specification

2.2.7 Internal corrosion protection

- Glass flake lining
- Special paint/coatings according to customer specifications

2.2.8 Explosion protection

- ATEX according to Directive 94/9/EC

2.2.9 Documentation

- Manufacturer's test certificates
- Material certificates 3.1
- GOST certificate
- 3rd parties (TÜV, ABS, Lloyds, etc.)
- WPS / PQR
- Inspection plan

And many others available on request

2.3 OVERVIEW OF TECHNICAL SPECIFICATIONS OF STANDARD MODELS

Filter Size	Pressure range [bar]	Connection ¹⁾ Inlet	Connection ¹⁾ Outlet	Connection back-flushing line	Weight ²⁾ [kg]	Volume [l]	No. of elements	Filtration area [cm ²]	Backflush volume ³⁾ [l]
C	16	DN 50	DN 50	DN 25	130	15	6 x KC	2140	25
0	10	DN 100	DN 100	DN 25	155	25	6 x K0	3810	25
1	10	DN 150	DN 150	DN 40	250	60	3 x K1 3 x K2	6190	35
2	10	DN 200	DN 200	DN 50	375	105	4 x K1 4 x K2	8250	50
2.5	10	DN 250	DN 250	DN 50	645	190	6 x K3	12500	65
3	10	DN 300	DN 300	DN 65	585	280	9 x K3	18750	95
4	6	DN 400	DN 400	DN 80	775	425	18 x K3	37500	210
5	6	DN 500	DN 500	DN 80	1040	635	16 x K3 8 x K4	55760	310
6	6	DN 600	DN 600	DN 100	1650	998	32 x K3 8 x K4	89100	485
7	6	DN 700	DN 700	DN 100	2000	1355	24 x K3 20 x K4	106100	555
8	6	DN 900	DN 900	DN 150	3610	2710	54 x K5	180700	720

Max. permissible temperature for all AutoFilt® RF7: 90 °C

- ¹⁾ According to DIN/EN standard / reservoir manufacture to AD2000, application of Pressure Equipment Directive 97/23/EC if required
- ²⁾ Approx. empty weight based on standard pressure range
- ³⁾ Based on EPT/PT control mode with opening time of backflushing valve of 1.5 seconds and 1.5 bar differential pressure between outlet and backflushing line, with EU / EPU control the backflushing volume increases by a factor of 5.

2.4 CIRCUIT DIAGRAM

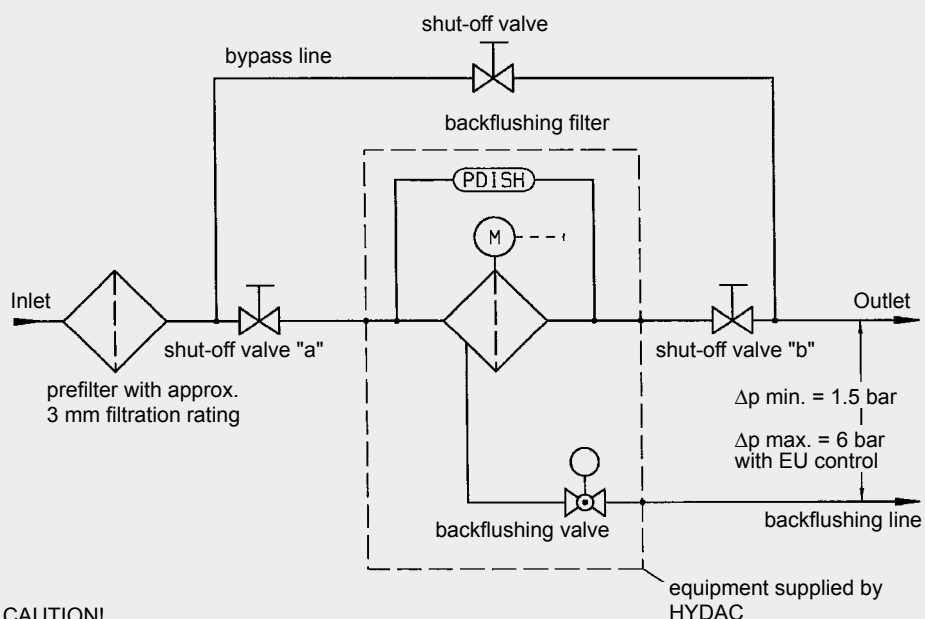

CAUTION!
For cleaning, there must be a minimum pressure difference between the outlet and the backflushing line of 1.5 bar.

3. MODEL CODE AUTOFILT® RF7

RF7 - 3B - EPT1 - NP - N - 1 - 1A - x / SKS 100 - 3 - 12345678

Type AutoFilt®

Size / filter inlet - filter outlet

- C = DN 50 PN16
- 0 = DN100 PN10
- 1 = DN150 PN10
- 2 = DN200 PN10
- 2.5 = DN250 PN10
- 3 = DN300 PN10
- 4 = DN400 PN6
- 5 = DN500 PN6
- 6 = DN600 PN6
- 7 = DN700 PN6
- 8 = DN900 PN6
- A = PN6 (follows size)
- B = PN10 (follows size)
- C = PN16 (follows size)
- D = PN25 (follows size)

Type of control / Input supply voltage

- EU = electrical time-controlled circulation control
- EPT = electro-pneumatic cyclic control
- PT = pneumatic cyclic control
- EPU = electro-pneumatic circulation control
- PTZ = pneumatic cyclic control with timer function
- 0 = without control, all users on terminal strip/block
- 1 = 3 x 400V / N / PE 50Hz
- 2 = 3 x 400V / x / PE 50Hz
- 3 = 3 x 500V / x / PE 50Hz
- 4 = 3 x 230V / N / PE 50Hz
- 5 = 3 x 230V / x / PE 50Hz
- 6 = 3 x 415V / x / PE 50Hz
- 7 = 3 x 415V / N / PE 60Hz
- 8 = 3 x 460V / x / PE 60Hz
- 9 = 3 x 440V / x / PE 60Hz
- A = 3 x 525V / x / PE 50Hz
- B = 3 x 575V / x / PE 60Hz
- C = 3 x 690V / x / PE 50Hz
- D = 1 x 230V / N / PE 50Hz
- E = 1 x 230V / N / PE 60Hz
- F = 1 x 115V / N / PE 60Hz

Housing material

- N = carbon steel, external primer (RAL 9006)
- NM = carbon steel, external primer (RAL 9006), 2K epoxy paint, internal
- NP = carbon steel, external primer (RAL 9006), 2K polyurethane paint, internal
- E = stainless steel
- A = for ANSI flanges, add A
- J = for JIS flanges, add J

Material of backflushing valve

- N = butterfly: housing SG cast iron coated, washer stainless steel
- B = butterfly: housing SG cast iron coated, washer bronze

Differential pressure gauge

- 1 = pressure chamber aluminium
- 2 = pressure chamber stainless steel
- 3 = with chemical seal stainless steel
- 4 = pressure chamber brass

Flange setting/ backflushing line setting (each in the direction of the filter inlet)

- 1 = outlet to right
- 2 = outlet up
- 3 = outlet to left
- A = backflushing line to left
- B = backflushing line downwards
- C = backflushing line to right

Modification number

- X = the latest version is always supplied

Element set

- KS = conical slotted tube (50 µm - 3000 µm)
- KD = conical SuperMesh (25, 40, 60 µm)
- SKS = conical slotted tube, coated with SuperMesh
- SKD = conical SuperMesh coated with Superflush

Size of element set

Identical to size of filter

Drawing number

For special models
(number is allocated after technical clarification at Head Office)

4. FILTER CALCULATION / SIZING

4.1 PRESSURE DROP CURVES

The pressure drop curves apply to water.

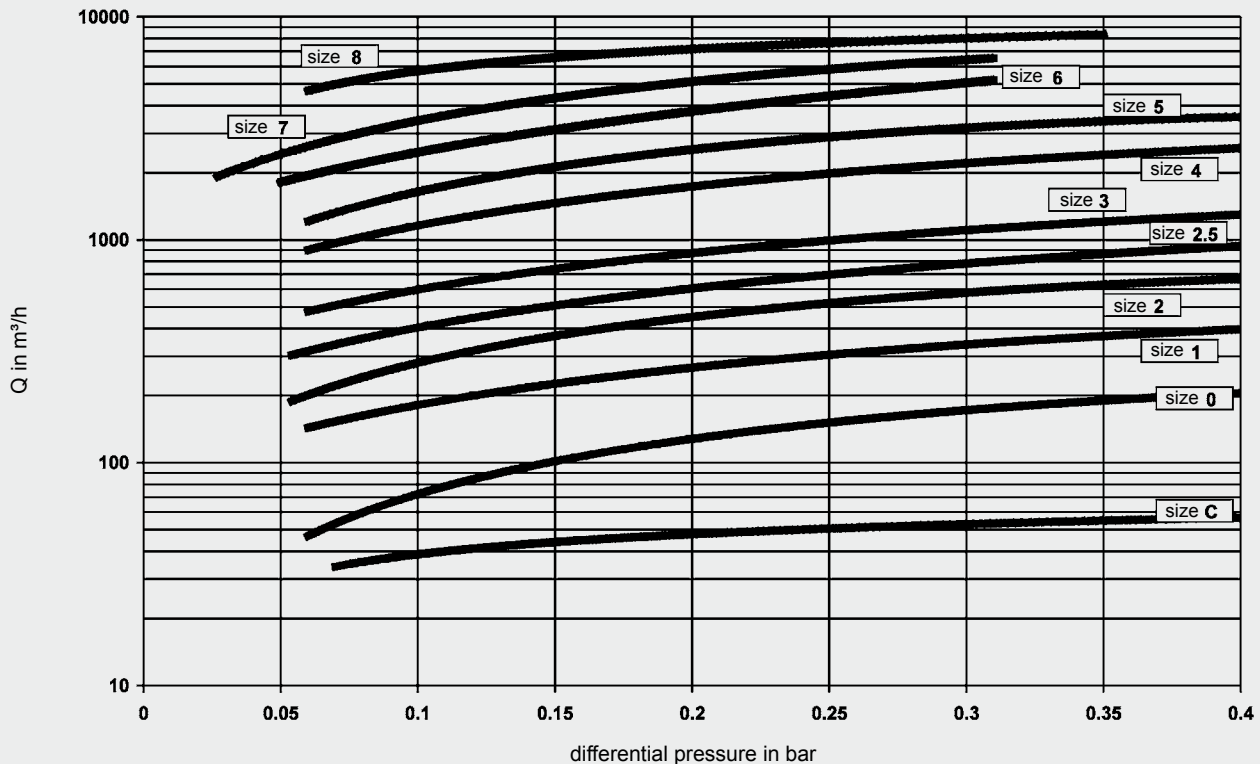

It is crucial when operating the AutoFilt® RF7 that there is a pressure differential between the backflushing line and the filter outlet of at least 1.5 bar. This minimum pressure differential ensures the operation of the filter.

In order to be able to size the filter correctly, the following design data should be available:

(see also Filter questionnaire)

- Flow rate
- Type of medium
- Materials
- Viscosity
- Required filtration rating
- Particulate loading in the fluid
- Type of contamination
- Operating pressure
- Operating temperature
- Power supply and compressed air supply
- Pressure ratios after the AutoFilt® RF7 (is there any back pressure?)
- Integration of the AutoFilt® RF7 into the whole system

The AutoFilt® RF7 is sized based on the pressure drop curve and the calculation table. Generally speaking, an initial Δp (clean filter condition) of 0.2 bar should not be exceeded. The pressure drop curve is valid for filtration ratings of 100 – 3000 μm slotted tube and 25 μm , 40 μm and 60 μm SuperMesh. Using 50 μm

slotted tubes, the stated pressure drop increases for sizes C to 8 by approx. 30 %. A further factor in the calculation is the flow velocity through the filter inlet. It should not exceed 4 m/s.

With reference to the sizing of the AutoFilt® RF7, a separate consideration and sizing must be applied for water applications and emulsion applications due to different contamination loads (see 4.2 Calculation Tables).

4.2. CALCULATION TABLES

The calculation tables form an important basis when deciding on the AutoFilt® RF7.

In particular the higher contamination load in emulsion applications demands more generous sizing of the filter. The following points must also be observed for emulsion applications:

- Validity of the tables for emulsions and oils up to a viscosity of 15 mm^2/s .
- For applications in the field of cast iron processing, grinding, honing and for fluids with a viscosity over 15 mm^2/s , you must contact the Head Office!

- The flow rate ranges given apply to filtration ratings $\geq 100 \mu\text{m}$.

4.2.1 Water applications

Filter Size	Flow rate range
C	5 - 28 m^3/h
0	25 - 113 m^3/h
1	90 - 254 m^3/h
2	200 - 450 m^3/h
2.5	400 - 600 m^3/h
3	550 - 860 m^3/h
4	810 - 1700 m^3/h
5	1500 - 2450 m^3/h
6	2000 - 3600 m^3/h
7	3000 - 5000 m^3/h
8	4500 - 7500 m^3/h

4.2.2 Emulsion applications (cooling lubricants, washing fluids)

Filter Size	Flow rate range
C	5 - 15 m^3/h
0	10 - 60 m^3/h
1	40 - 100 m^3/h
2	90 - 200 m^3/h
2.5	100 - 350 m^3/h
3	150 - 450 m^3/h
4	200 - 650 m^3/h
5	350 - 950 m^3/h
6	700 - 1500 m^3/h
7	1000 - 1700 m^3/h
8	1300 - 3000 m^3/h

5. DIMENSIONS

The dimensions indicated relate to the standard pressure ranges.

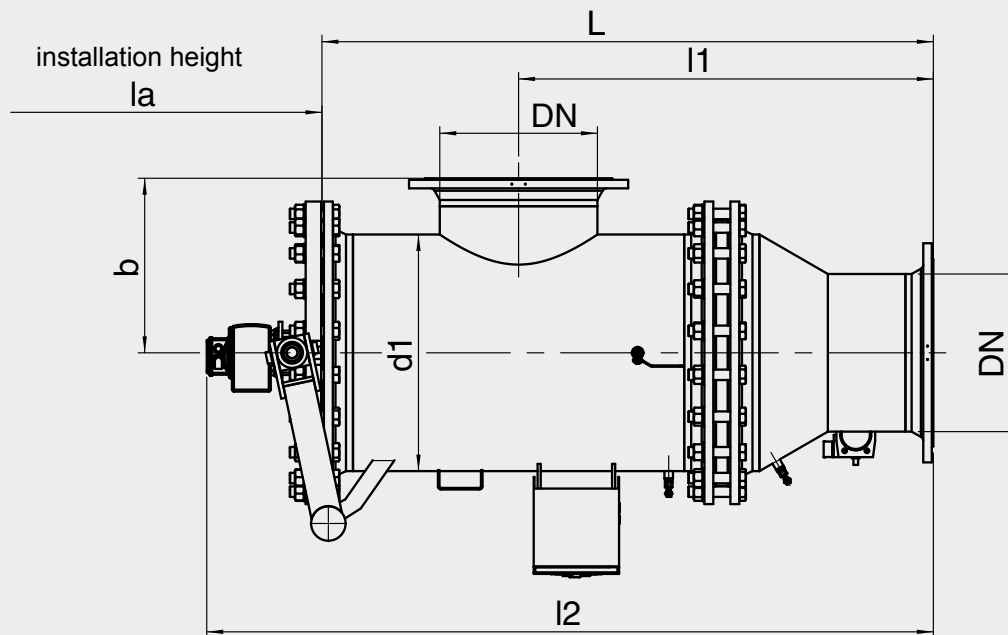
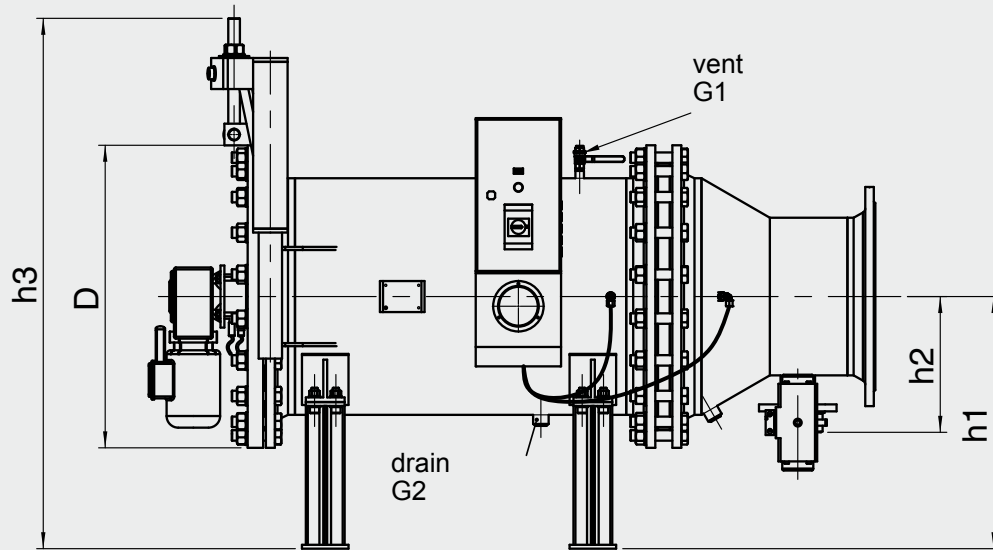

Filter Size	DN	DN1	I1	b	h1	h2	h3	D	d1	L	I2	G1	G2	la
C	50	25	504	200	360	120	650	340	220	635	892	G1/4	G1/2	550
0	100	25	596	200	385	150	685	340	220	850	1165	G1/4	G1/2	550
1	150	40	647	270	450	189	805	445	324	900	1215	G1/4	G3/4	550
2	200	50	764	325	500	220	1000	565	406	1020	1335	G1/4	G3/4	700
2.5	250	50	1024	325	500	260	1000	565	406	1480	1770	G1/4	G3/4	700
3	300	65	1042	380	590	280	1200	670	508	1550	1848	G1/4	G3/4	700
4	400	80	1069	450	650	350	1400	780	610	1576	1873	G1/4	G3/4	700
5	500	80	1139	550	750	370	1575	895	711	1585	1920	G1/4	DN40	700
6	600	100	1159	625	840	475	1750	1115	914	1690	2046	G1/4	DN40	700
7	700	100	1200	750	890	510	1900	1230	1016	1475	1830	G1/4	DN40	700
8	900	150	1474	950	1100	620	2250	1405	1220	2114	2460	G1/4	DN40	700

NOTE

The information in this brochure relates to the operating conditions and applications described.
For applications or operating conditions not described, please contact the relevant technical department.
Subject to technical modifications.

HYDAC Process Technology GmbH
Am Wrangelflöz 1
D-66538 Neunkirchen
Tel.: +49 (0)6897 - 509-1241
Fax: +49 (0)6897 - 509-1278
Internet: www.hydac.com
E-Mail: prozess-technik@hydac.com

