

Mobile Controller HY-TTC 77

Description

The HY-TTC 77 is a powerful controller for mobile off-highway applications with 12 V voltage supply.

The design of the HY-TTC 77 meets the requirements for **PL d** (Performance Level) of the international standard EN ISO 13849.

The CPU XC 2288 H from Infineon used in the controller has enhanced safety features for protecting the internal RAM and Flash memory.

The HY-TTC 77 is part of a complete and compatible product series. It is protected by a robust and extremely compact housing which was specially designed for the off-highway vehicle industry.

Special features

- Programming in C
- 138 kB RAM
- 65 inputs and outputs
 - 26 power outputs
 - 30 analogue inputs
 - 7 digital inputs
 - 6 PWM current measurement
 - 2 Timer IN optional
- All inputs and outputs are configurable and are protected against overvoltage and short circuits
- Stabilised sensor voltage supply with internal monitoring
- No reset caused by dip in voltage when engine is started
- Robust aluminium die-cast housing with a waterproof 80-pole male connection and pressure equalization via a waterproof Gore-Tex® membrane
- E12 type approval

Technical data

Environmental conditions	
Operating temperature	-40 .. +85 °C (full load) acc. to EN 60068-2
Operating altitude	0 .. 4,000 m
Supply voltage	8 .. 16 V
Permitted voltage drop	up to ≥ 4 V (U _{BAT}) without reset to ISO 7637-1 (for engine start in 12 V systems)
Peak voltage	45 V max. (1 ms)
Idle current	0.15 A max. at 9 V
Standby current	0.5 mA max.
Current consumption	40 A max. (complete voltage and temperature range)
Fulfils the following standards	
CE mark	Compliant with 2014/30/EU
E-mark	ECE-R10 Rev.3
EMC	ISO 13766 (up to 100 V/m, 20 MHz .. 1 GHz)
ESD	IEC 61000-4-2
Protection class	EN 60529 IP 65 / IP 67 DIN 40050 IP 6k9k
Temperature	EN 60068-2-1; -14Nb; -2; -78; -30
Vibration, shock, bump	IEC 60068-2-29; -64; -27; -32
Dimensions and weight	
Housing dimensions	148 x 181 x 40 mm
Minimum clearance for connection	198 x 203 x 40 mm
Weight	640 g
Features	
16-bit Infineon XC 2288 microcontroller, 80 MHz, 1.6 MB int. Flash, 138 kB int. RAM	
32 kByte EEPROM	
2 x CAN, 125 kbit/s .. 1 Mbit/s	
CPU-internal safety features:	
• Hardware CRC testing of the Flash memory	
• Integrated memory protection (MPU)	
• RAM protected by means of error correcting code (ECC)	
Watchdog CPU Freescale HC908, including monitoring software	
12 x PWM OUT 2.5 A high-side with frequency measurement, of which 6 with current measurement; PL d classified; configurable as Timer IN; 3 output groups can be shut down independently in the case of malfunction for emergency operation	
6 x PWM OUT 2.5 A high-side with voltage measurement; up to 4 A for individual outputs (4 PWM OUT PL c classified)	
8 x Digital OUT 2.5 A high-side; up to 4 A for individual outputs	
4 x Analogue IN 0 .. 5 V / 0 .. 24 mA / resistive / Digital IN low-side; 10 bit; configurable via software; PL d classified	
8 x Analogue IN 0 .. 15 V / Digital IN; 10 bit; PL d classified	
8 x Analogue IN 0 .. 5 V / 10 bit; PL d classified	
8 x Analogue IN 0 .. 10 V or Digital IN; high-side/low-side; 9 bit; PL d classified	
2 x Analogue IN 0 .. 15 V; 10 bit; PL d classified	
2 x Digital Timer IN (0.1 Hz .. 10 kHz); PL d classified, not populated	
7 x Digital IN high-side	
Internal monitoring of board temperature, sensor supply and battery	
3 x analogue sensor ground, 1 x digital ground	
2 x sensor supply 5 V, each 100 mA	
Programming: C	

Note: All I/Os and interfaces are protected against short circuit to GND and BAT+.

Block circuit diagram

HY-TTC 77

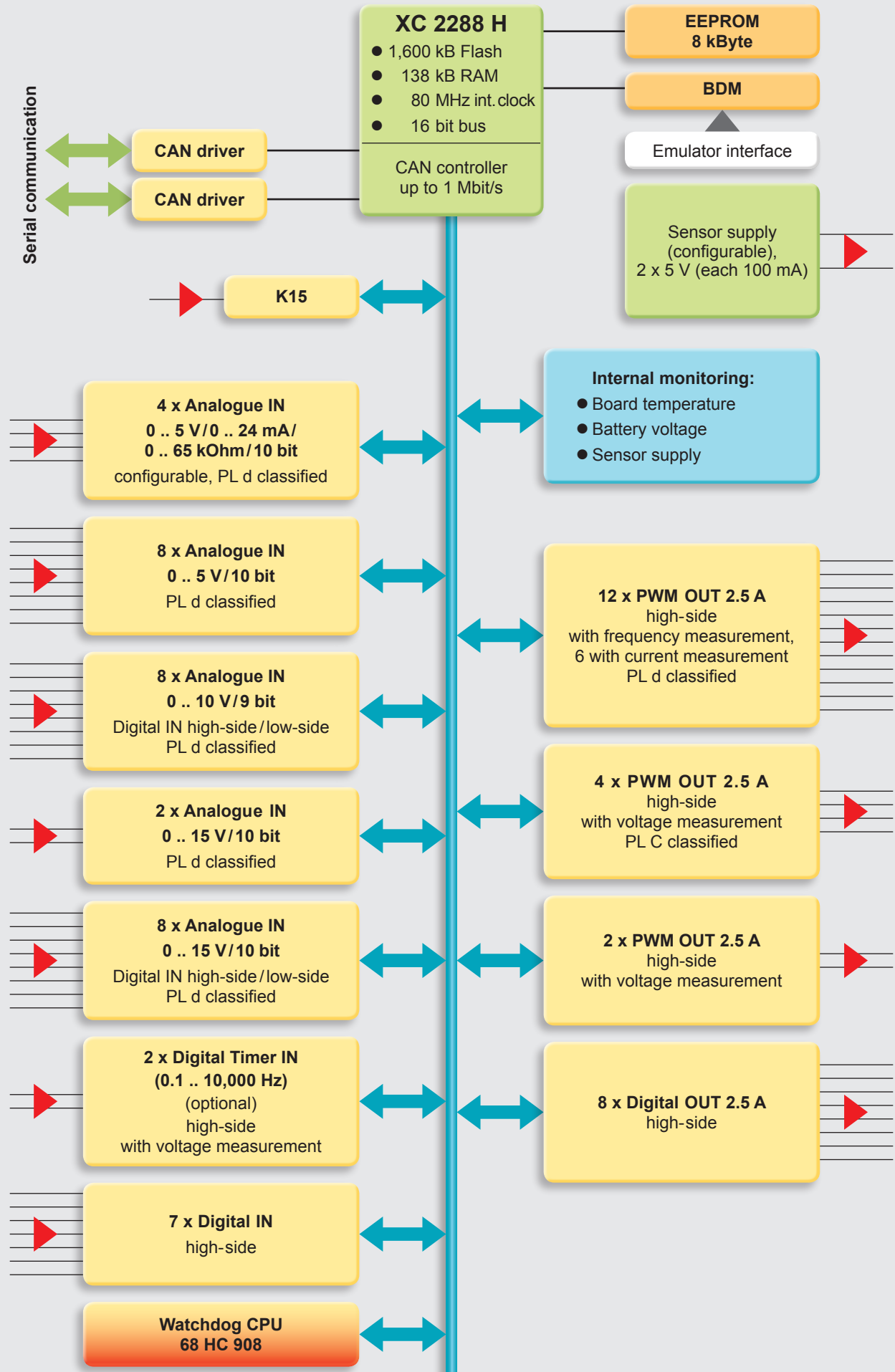

Model code

HY-TTC 77 – XX – 138K – 1.6M – WD XX – 000

Firmware

CP = for C programming without CODESYS

RAM memory

138K = 138 kByte

Flash memory

1608K = 1608 kByte/1.6 MByte

Functional safety

WD = Watchdog with standard software

Equipment options

05 = full configuration

10 = open housing/developer version

Modification number

000 = standard

Note

On devices with a different modification number, please read the name plate or the technical amendment details supplied with the device.

Accessories

Appropriate accessories, such as cable harnesses, cabling and connection technology, service tools and software can be found in the Accessories section.

Note

The information in this brochure relates to the operating conditions and applications described.

For applications or operating conditions not described, please contact the relevant technical department.

Subject to technical modifications and corrections.

Dimensions

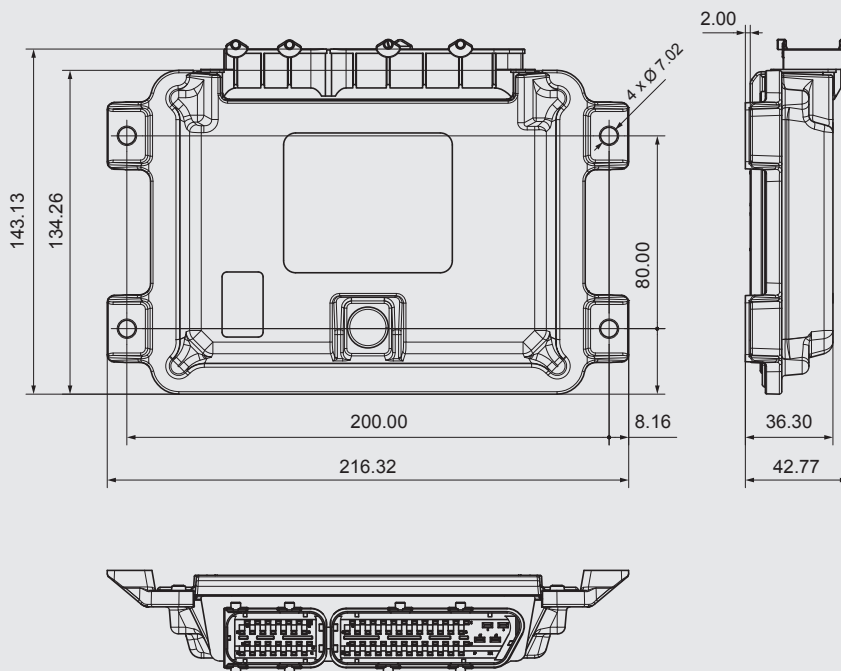

HYDAC ELECTRONIC GmbH

Hauptstr. 27

66128 Saarbrücken, Germany

Tel. +49 6897 509-01

Fax +49 6897 509-1726

E-mail: electronic@hydac.com

Internet: www.hydac.com

