

Compact Controller HY-TTC 30-H



Description

The HY-TTC 30-H is a compact controller, based on an Infineon XC22xx microcontroller, which was specially designed for use in low-cost applications or smaller machines. Thirty freely configurable I/Os enable it to be operated with a wide variety of sensors and actuator types.

The 30-H version is best suited to controlling proportional functions. Six out of the eight PWM outputs have integrated current measurement which means that up to three hydraulic axes can be current-controlled.

The module was developed in accordance with EN ISO 13849 and is suitable for applications with PL b (Performance Level b).

The HY-TTC 30-H was specially developed for vehicles and machines used in rugged operating environments and at extreme operating temperatures.

The module is protected in a proven, robust and compact housing, specially designed for the off-highway automotive industry.

Special features

- 30 inputs and outputs:
 - 10 analogue inputs
 - 4 timer inputs
 - 8 PWM outputs, high-side:
 - 6 with integrated current measurement
 - 2 digital outputs, low-side
 - 6 ratiometric voltage outputs
- Robust, very compact die-cast aluminium housing
- Waterproof, 48-pin male connection
- Suitable for EN ISO 13849 PL b

Technical data

Environmental conditions	
Operating temperature	-40 .. +85 °C (with full load)
Operating altitude	0 .. 4,000 m
Supply voltage	8 .. 32 V
Peak voltage	40 V max.
Idle current	40 .. 120 mA
Standby current	≤ 1 mA
Current consumption	24 A max.
Fulfils the following standards	
CE mark	Compliant with 2014/30/EU
E-mark	ECE-R10 Rev.4
EMC	EN 13309/ISO 14982/CISPR 25
ESD	ISO 10605
Electrical	ISO 16750-2/ISO 7637-2/-3, limited to 40 V with external load dump protection
Protection class	EN 60529 IP 67/ISO 20653 IP 6K9K
Temperature	ISO 16750-4
Vibration, shock, bump	ISO 16750-3
Dimensions and weight	
Housing dimensions	147 x 92 x 38 mm
Minimum clearance for connection	208 x 94 x 38 mm
Weight	330 g
Features ¹⁾²⁾³⁾	
Infineon XC 22xx microcontroller, 80 MHz, 768 kB int. Flash, 82 kByte int. RAM	
8 kByte EEPROM	
1 x CAN, 50 kbit/s up to 1 Mbit/s with configurable termination	
2 x Node ID pins for optional configuration of CAN ID	
IN	
6 x Analogue IN 0 .. 5 V / 0 .. 10 V or 0 .. 25 mA or 25 mA LED lamps OUT configurable via software	
2 x Analogue IN 0 .. 5 V / 0 .. 10 V / 0 .. 25 mA / 0 .. 65 kOhm or 25 mA LED lamps OUT configurable via software	
2 x Analogue IN 0 .. 32 V with configurable pull-up/down in digital input mode	
4 x Timer IN (Timer inputs 0.1 Hz .. 10 kHz) / Analogue IN 0 .. 32 V configurable pull-up/down, 1 encoder	
OUT	
6 x PWM OUT 3 A high-side, current measurement, overload and wirebreak detection configurable as 6 x Timer IN (10 Hz .. 10 kHz) / Analogue IN 0 .. 32 V with integrated pull-up	
2 x PWM OUT/Digital OUT 3 A high-side, overload and wirebreak detection configurable as 2 x Timer IN (10 Hz .. 10 kHz) / Analogue IN 0 .. 32 V with integrated pull-up	
2 x Digital OUT 3 A low-side, overload and wirebreak detection configurable as 2 x Analogue IN 0 .. 32 V with integrated pull-up	
6 x Analogue OUT 15 % .. 85 % V _{BAT+} (ratiometric) configurable as 0 V .. 75 V _{BAT+} with 10 kOhm low-side load or 6 x Analogue IN 0 .. 32 V	
Dedicated power supply pins for high-side outputs	
Internal monitoring of board temperature, sensor supply, K15 input and battery voltage	
1 x sensor supply 5 V (100 mA)	
Programming: C	

Note: ¹⁾ All I/Os and interfaces are protected against short circuit to GND and BAT+.

²⁾ All analogue inputs have 10-bit resolution.

³⁾ All analogue inputs can be used as digital inputs with configurable switching thresholds.

Block circuit diagram

HY-TTC 30-H

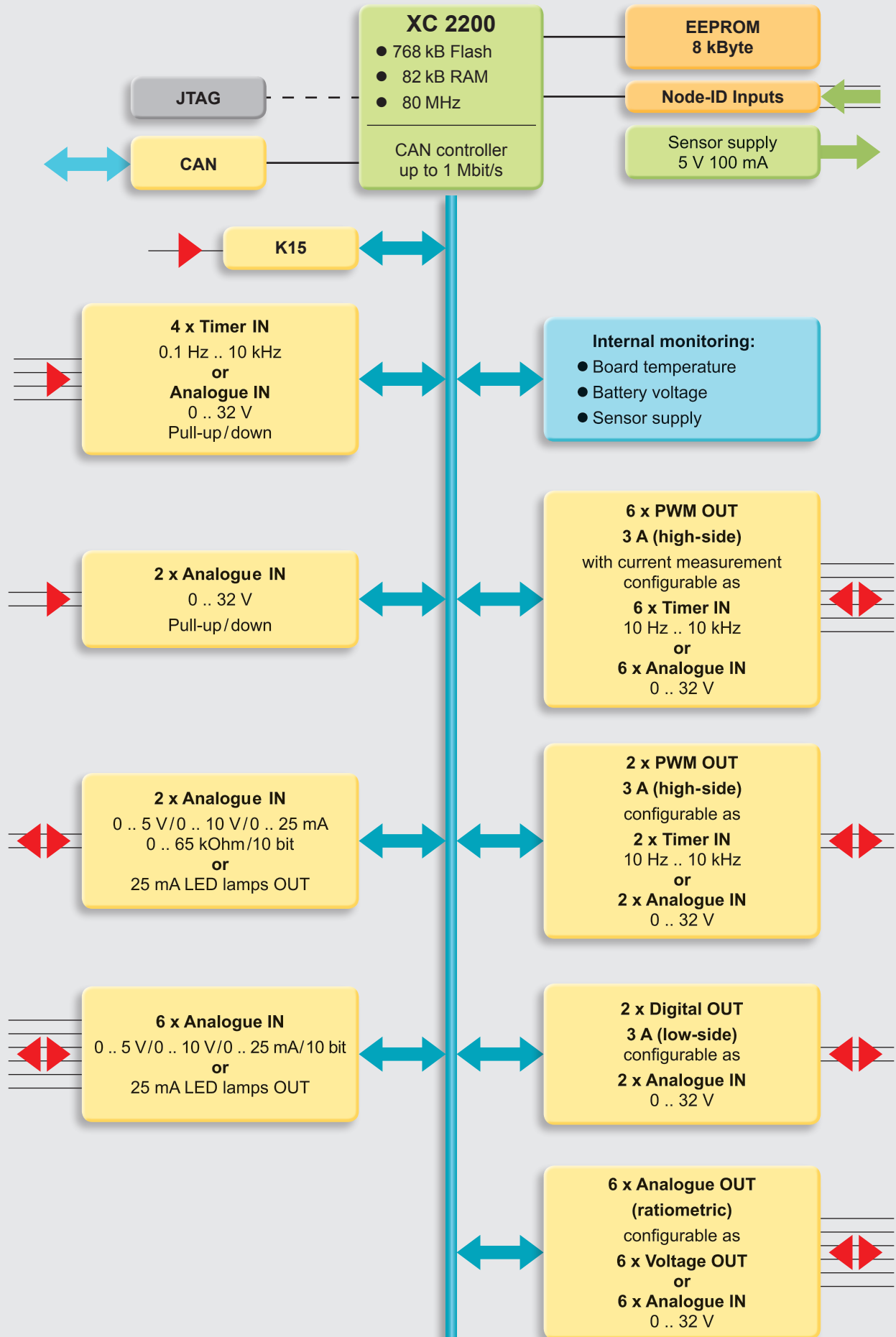

Model code

HY-TTC 30 – H – XX – XX – 000

Firmware

CP = C programming

Equipment option

00 = standard

10 = developer version

Modification number

000 = standard

Note

On devices with a different modification number, please read the name plate or the technical amendment details supplied with the device.

Accessories

Appropriate accessories, such as cable harnesses, cabling and connection technology, service tools and software can be found in the Accessories section.

Note

The information in this brochure relates to the operating conditions and applications described.

For applications or operating conditions not described, please contact the relevant technical department.

Subject to technical modifications and corrections.

Dimensions

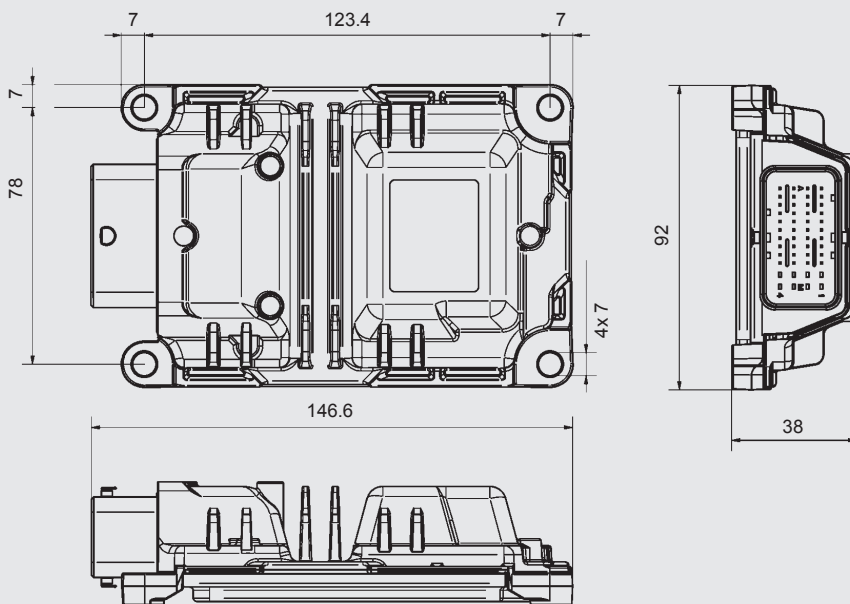

HYDAC ELECTRONIC GmbH

Hauptstr. 27

66128 Saarbrücken, Germany

Tel. +49 6897 509-01

Fax +49 6897 509-1726

E-mail: electronic@hydac.com

Internet: www.hydac.com

