



Compact I/O Expansion Module HY-TTC 30XS-H

Functional safety
PL c

Description

The HY-TTC 30XS-H module was developed for distributed applications with increased functional safety.

Using the general standard, CANopen Safety to EN 50325-5 and CIA DS 401, the module can be easily controlled and integrated in the existing control system.

The HY-TTC 30XS-H module was developed in accordance with the international standard ISO/EN 13849 and is certified by TÜV NORD. It meets the requirements of Functional Safety according to **PL c** (Performance Level c).

The 30XS-H version has been optimised for system expansion to include additional hydraulic functions.

The module is protected in a proven, robust and compact housing, specially designed for the off-highway automotive industry.

Special features

- **PL c certified**
- 30 inputs and outputs:
 - 10 analogue inputs
 - 4 timer inputs
 - 8 PWM outputs, high-side:
 - 6 with integrated current measurement
 - 2 digital outputs, low-side
 - 6 ratiometric voltage outputs
- Freely configurable Node ID via pin
- Robust, very compact die-cast aluminium housing
- Waterproof, 48-pin male connection
- E12 type approval

Technical data

| Environmental conditions | |
|---|--|
| Operating temperature | -40 .. +85 °C (with full load) |
| Operating altitude | 0 .. 4,000 m |
| Supply voltage | 8 .. 32 V |
| Peak voltage | 40 V max. |
| Idle current | 40 .. 120 mA |
| Standby current | ≤ 1 mA |
| Current consumption | 24 A max. |
| Fulfils the following standards | |
| CE mark | Compliant with 2014/30/EU, 2006/42/EC |
| E-mark | ECE-R10 Rev.4 |
| Functional safety | EN ISO 13849 PL c |
| EMC | EN 13309/ISO 14982/CISPR 25 |
| ESD | ISO 10605 |
| Electrical | ISO 16750-2/ISO 7637-2-3, limited to 40 V with external load dump protection |
| Protection class | EN 60529 IP 67/ISO 20653 IP 6K9K |
| Temperature | ISO 16750-4 |
| Vibration, shock, bump | ISO 16750-3 |
| Communication profile | CANopen CiA DS 401 |
| Dimensions and weight | |
| Housing dimensions | 147 x 92 x 38 mm |
| Minimum clearance for connection | 208 x 92 x 38 mm |
| Weight | 330 g |
| Features ¹⁾²⁾³⁾⁴⁾⁵⁾ | |
| Infineon XC 22xx microcontroller, 80 MHz, 768 kB int. Flash, 82 kByte int. RAM | |
| 8 kByte EEPROM | |
| 1 x CAN, 125 kbit/s up to 1 Mbit/s, termination configurable via pin | |
| 2 x Node ID pin for optional configuration of the CANopen ID | |
| IN | |
| 6 x Analogue IN 0 .. 5 V/0 .. 10 V/0 .. 25 mA or 25 mA LED lamp OUT configurable via software, PL c capable when used in pairs | |
| 2 x Analogue IN 0 .. 5 V/0 .. 10 V/0 .. 25 mA/0 .. 65 kOhm or 25 mA LED lamp OUT configurable via software, PL c capable when used in pairs | |
| 2 x Analogue IN 0 .. 32 V with configurable pull-up/down, digital voltage input mode, PL c capable when used in pairs | |
| 4 x Timer IN (Timer inputs 0.1 Hz .. 10 kHz)/Analogue IN 0 .. 32 V configurable pull-up/down in digital voltage input mode, 1 encoder, PL c capable when used in pairs | |
| OUT | |
| 6 x PWM OUT/Digital OUT 3 A high-side, current measurement, overload and wirebreak detection configurable as Timer IN (10 Hz .. 10 kHz)/Analogue IN 0 .. 32 V with integrated pull-up, PL c capable | |
| 2 x PWM OUT/Digital OUT, 3 A high-side, overload and wirebreak detection configurable as Timer IN (10 Hz .. 10 kHz)/Analogue IN 0 .. 32 V with integrated pull-up, PL c capable | |
| 2 x Digital OUT 3 A low-side, for use as safety switch for high-side PWM OUTs ⁵⁾ | |
| 6 x Analogue OUT 15 % .. 85 % V _{BAT+} (ratiometric) configurable as 0 V .. 75 % V _{BAT+} with 10 kOhm low-side load or Analogue IN 0 .. 32 V | |
| Dedicated power supply pins for high-side outputs | |
| Internal monitoring of board temperature, sensor supply, K15 input and battery voltage | |
| 1 x sensor supply 5 V (100 mA) | |

Note: ¹⁾ All I/Os and interfaces are protected against short circuit to GND and BAT+.

²⁾ All analogue inputs have 10-bit resolution.

³⁾ All analogue inputs can be used as digital inputs with configurable switching thresholds.

⁴⁾ All inputs can be used for functional safety, if two inputs of the same type are connected in parallel for redundancy.

⁵⁾ These outputs are part of the safety design and cannot be controlled directly via the software.

Block circuit diagram

HY-TTC 30XS-H

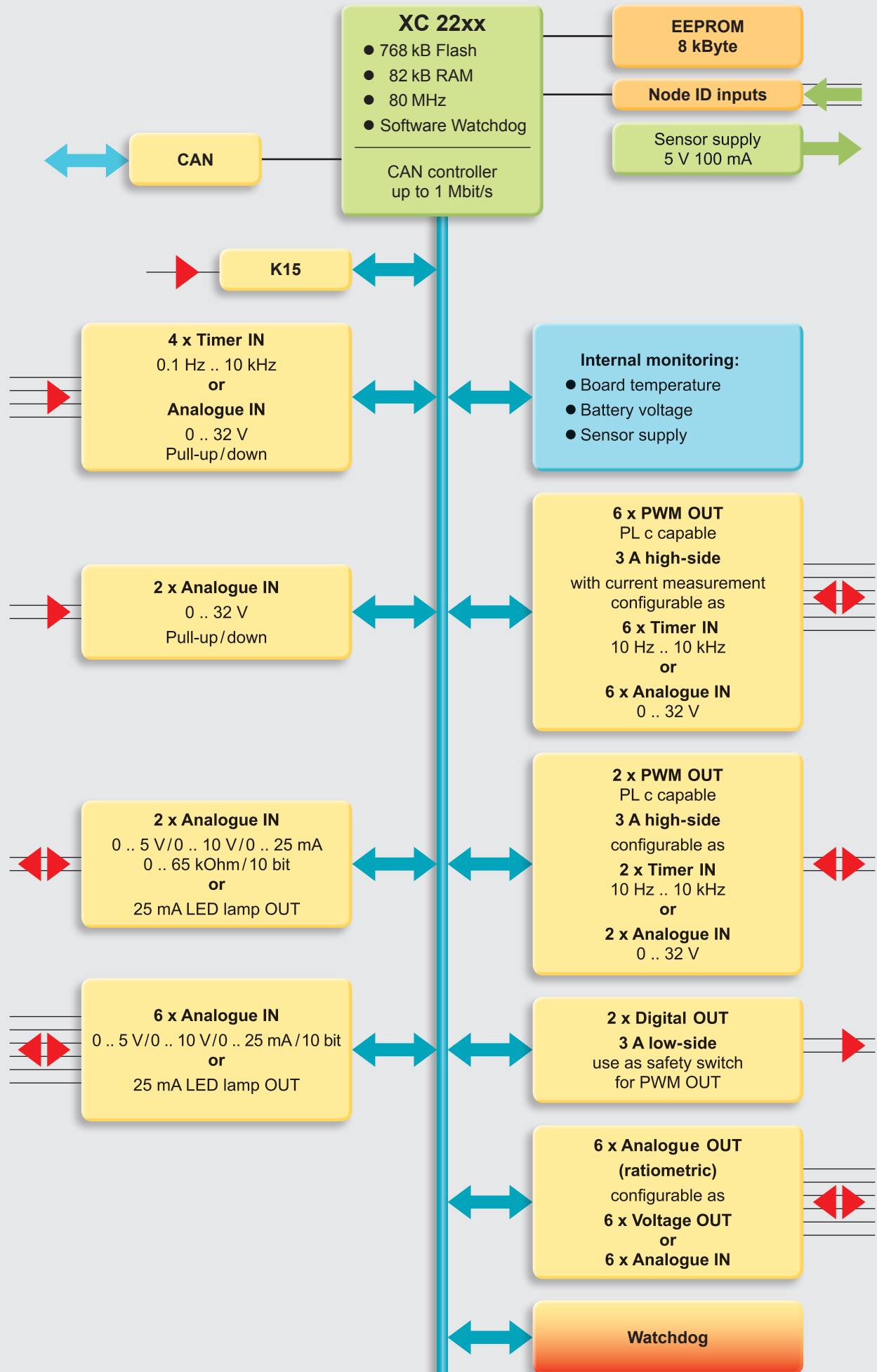

Model code

HY-TTC 30XS – H – F13 – 00 – Pc – 000

CAN protocol

F13 = CANopen Safety slave

Equipment option

00 = standard

Functional safety

Pc = requirements for PL c

Modification number

000 = standard

Note

On devices with a different modification number, please read the name plate or the technical amendment details supplied with the device.

Accessories

Appropriate accessories, such as cable harnesses, cabling and connection technology, service tools and software can be found in the Accessories section.

Note

The information in this brochure relates to the operating conditions and applications described.

For applications or operating conditions not described, please contact the relevant technical department.

Subject to technical modifications and corrections.

Dimensions

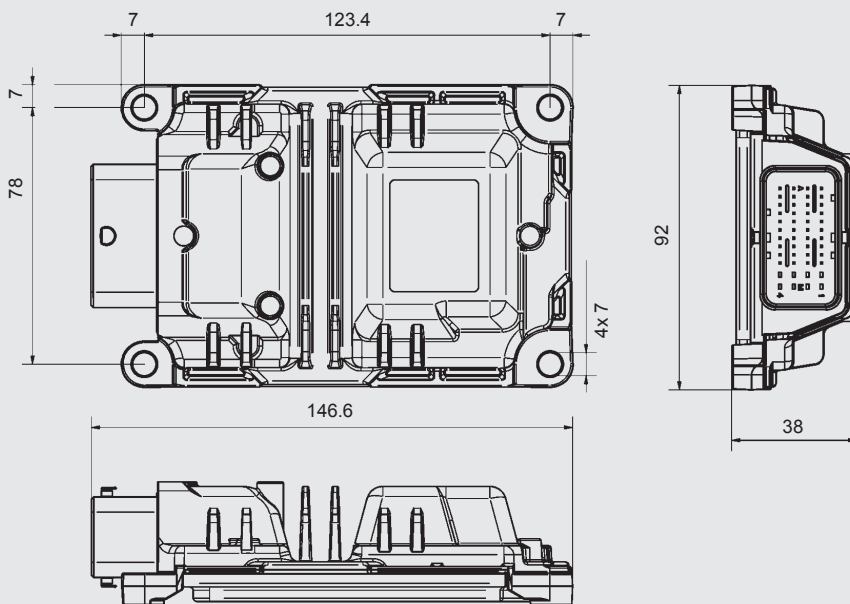

HYDAC ELECTRONIC GmbH

Hauptstr. 27
66128 Saarbrücken, Germany
Tel. +49 6897 509-01
Fax +49 6897 509-1726
E-mail: electronic@hydac.com
Internet: www.hydac.com

