

## Compact Controller HY-TTC 32



### Description

The HY-TTC 32 is a compact controller, based on an Infineon XC22xx microcontroller, which was specially designed for the use in low-cost applications or smaller machines. 30 freely configurable I/Os enable it to be operated with a wide variety of sensors and actuator types.

The HY-TTC 32 upgrades the successful HY-TTC 30 controller family with a compact control unit with two CAN interfaces. This makes it perfectly suitable for applications with heterogeneous CAN networks (e.g. CANopen + J1939).

With the opportunity of controlling up to three hydraulic axles including additional functions (6 \* PWM OUT with current measurement + 2 \* PWM), the HY-TTC 32 becomes one of the most powerful compact control units.

Like all of the devices of the controller family, this unit is also protected by our proven off-highway compact housing and has been developed for rough operating conditions and temperatures.

### Special features

- 30 inputs and outputs:
  - 10 analogue inputs
  - 4 timer inputs
  - 8 PWM outputs, high-side:
    - 6 with integrated current measurement
  - 2 digital outputs, low-side
  - 6 ratiometric voltage outputs
- Robust, very compact die-cast aluminium housing
- Waterproof, 48-pin male connection
- 2 CAN bus interfaces
- Suitable for EN ISO 13849 PL b

### Technical data

Environmental conditions	
Operating temperature	-40 .. +85 °C (with full load)
Operating altitude	0 .. 4,000 m
Supply voltage	8 .. 32 V
Peak voltage	40 V max.
Idle current	≤ 120 mA
Standby current	≤ 1 mA
Current consumption	24 A max.
Fulfils the following standards	
CE mark	Compliant with 2014/30/EU
E-mark	ECE-R10 Rev.4
EMC	EN 13309/ISO 14982/CISPR 25
ESD	ISO 10605
Electrical	ISO 16750-2/ISO 7637-2/-3, limited to 40 V with external load dump protection
Protection class	EN 60529 IP 67/ISO 20653 IP 6K9K
Temperature	ISO 16750-4
Vibration, shock, bump	ISO 16750-3
Dimensions and weight	
Housing dimensions	147 x 92 x 38 mm
Minimum clearance for connection	208 x 92 x 38 mm
Weight	330 g
Features <sup>1)2)</sup>	
Infineon XC 22xx microcontroller, 80 MHz, 768 kB int. Flash, 82 kByte int. RAM	
8 kByte EEPROM	
2 x CAN, 50 kbit/s .. 1 Mbit/s, 1 x with configurable termination	
IN	
4 x Analogue IN 0 .. 5 V/0 .. 10 V or 0 .. 25 mA or 25 mA LED lamps OUT configurable via software	
4 x Analogue IN 0 .. 5 V/0 .. 10 V/0 .. 25 mA/0 .. 65 kOhm or 25 mA LED lamps OUT configurable via software	
2 x Analogue IN 0 .. 32 V with configurable pull-up/down in digital input mode	
4 x Timer IN (Timer inputs 0.1 Hz .. 10 kHz)/Analogue IN 0 .. 32 V configurable pull-up/down, 1 encoder	
OUT	
6 x PWM OUT 3 A high-side, current measurement, overload and wirebreak detection configurable as 6 x Timer IN (10 Hz .. 10 kHz)/Analogue IN 0 .. 32 V with integrated pull-up	
2 x PWM OUT/Digital OUT 3 A high-side, overload and wirebreak detection configurable as 2 x Timer IN (10 Hz .. 10 kHz)/Analogue IN 0 .. 32 V with integrated pull-up	
2 x Digital OUT 3 A low-side, overload and wirebreak detection configurable as 2 x Analogue IN 0 .. 32 V with integrated pull-up	
6 x Analogue OUT 15 % .. 85 % V <sub>BAT+</sub> (ratiometric) configurable as 0 V .. 75 % V <sub>BAT+</sub> with 10 kOhm low-side load or 6 x Analogue IN 0 .. 32 V	
Dedicated power supply pins for high-side outputs	
Internal monitoring of board temperature, sensor supply, K15 input and battery voltage	
1 x sensor supply 5 V (100 mA)	
Programming: C, CODESYS	

**Note:** <sup>1)</sup> All I/Os and interfaces are protected against short circuit to GND and BAT+.  
<sup>2)</sup> All analogue inputs have 10-bit resolution.

# Block circuit diagram

HY-TTC 32

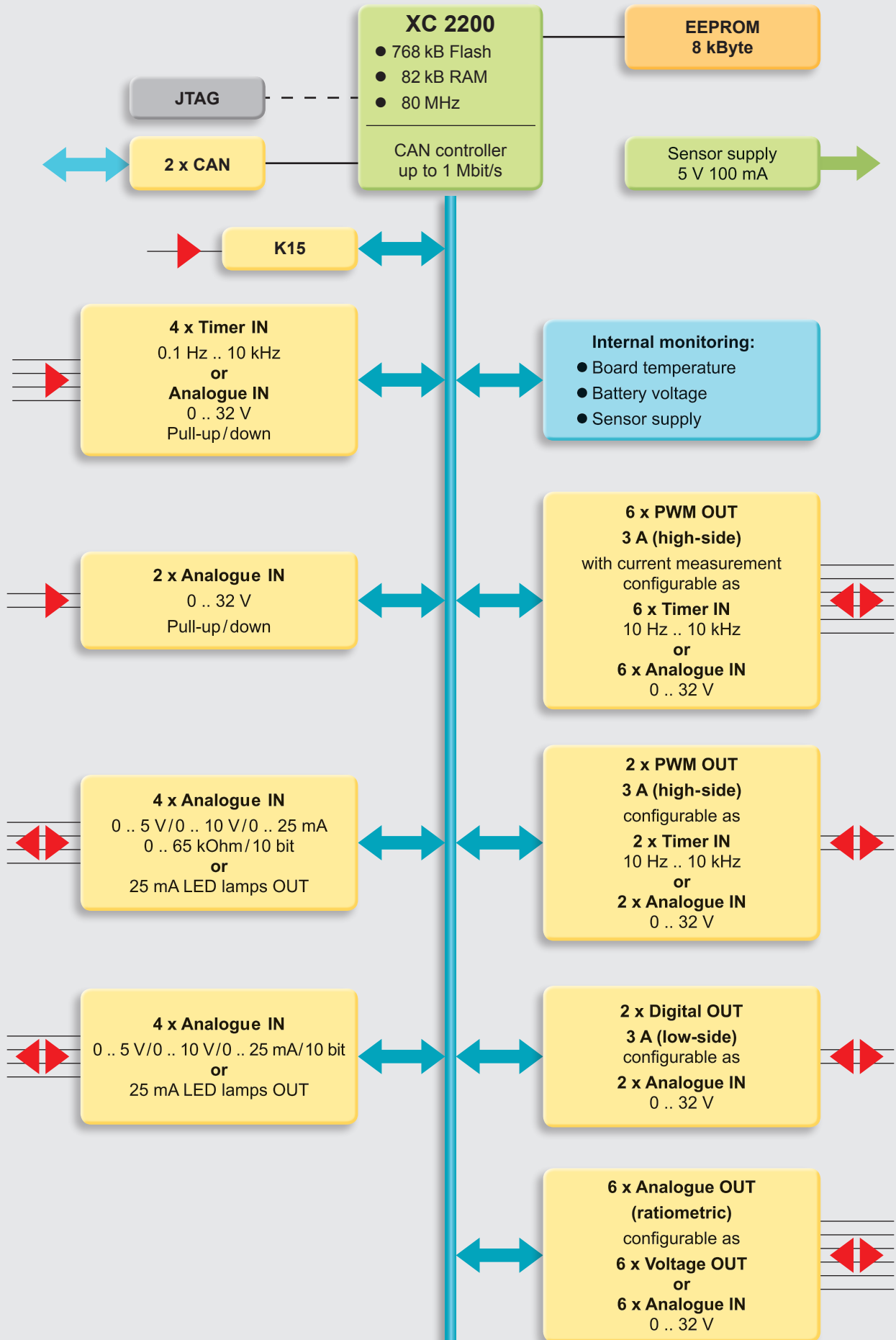

## Model code

HY-TTC 32 - XX - XX - 000

### Firmware

CP = C programming  
CD = CODESYS

### Equipment option

00 = standard  
10 = developer version

### Modification number

000 = standard

### Note

On devices with a different modification number, please read the name plate or the technical amendment details supplied with the device.

### Accessories

Appropriate accessories, such as cable harnesses, cabling and connection technology, service tools and software can be found in the Accessories section.

## Note

The information in this brochure relates to the operating conditions and applications described.

For applications or operating conditions not described, please contact the relevant technical department.

Subject to technical modifications and corrections.

## Dimensions

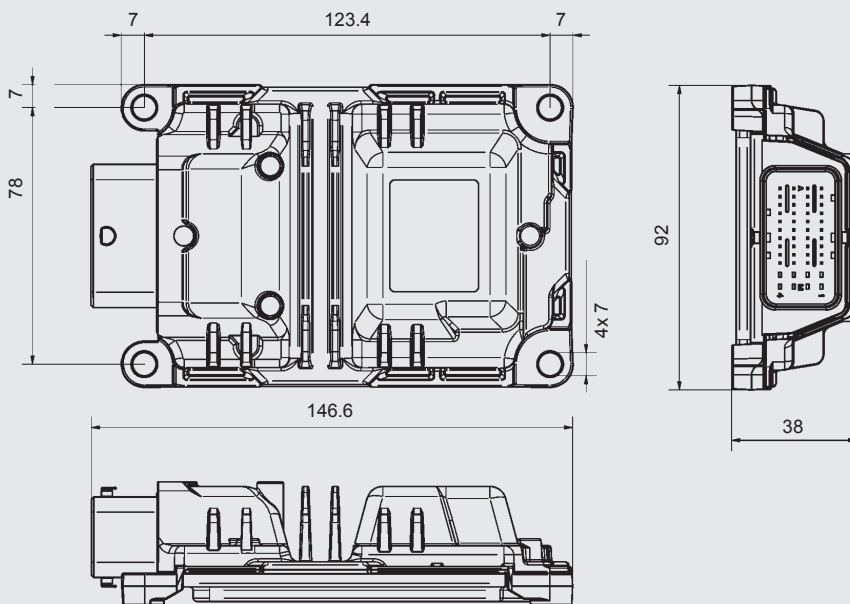

### HYDAC ELECTRONIC GmbH

Hauptstr. 27  
66128 Saarbrücken, Germany  
Tel. +49 6897 509-01  
Fax +49 6897 509-1726  
E-mail: [electronic@hydac.com](mailto:electronic@hydac.com)  
Internet: [www.hydac.com](http://www.hydac.com)

