



## Inclinometer HIT 1500

MEMS Technology

Motion compensated



CANopen

### Description:

In many applications, the measurement of the angle of inclination is required in order to ensure safe machine functions and to control processes.

HIT 1500 was developed in particular for the special use in dynamic system.

By using both an accelerometer and an additional gyroscope based on MEMS technology (Micro-Electro-Mechanical System), two measured variables which are entirely independent from one another from the physical point of view are detected by the HIT 1500 and combined.

A motion compensation is performed hence the contouring error, which occurs in damped or low-pass filtered systems, is avoided.

Thus, the HIT 1500 provides excellent dynamic characteristics and is therefore particularly suited for active orientation, stabilisation, and control of the inclination of mobile machines such as boom lifts and work platforms, cranes and mobile cranes, construction and drilling systems, agricultural, and municipal machines, etc.

Especially for the use in public traffic vehicles, HIT 1500 is approved for road vehicles according to ECE type approval.

### Technical data:

Input data	
<b>Inclination</b>	
Axes	1/ 2
Measuring range ("slope long")	$\pm 15^\circ / \pm 60^\circ / \pm 120^\circ / \pm 180^\circ$
Measuring range ("slope lateral")	$\pm 15^\circ / \pm 60^\circ / \pm 90^\circ$
Resolution	0.01 °
Dynamics	30 .. 50 Hz (-3 dB)
Update rate	200 Hz
Accuracy (static RMS)	< 0.1 ° over the entire measuring range
Temperature coefficient	Active temperature control, warm-up phase depending on ambient temperature <sup>1)</sup>
<b>Acceleration</b>	
Axes	3
Measurement range	$\pm 3 \text{ g}$ in 3 axes
Resolution	0.01 m/s <sup>2</sup>
Cutoff frequency	30 .. 50 Hz
<b>Gyro</b>	
Axes	3
Measurement range	$\pm 250 \text{ °/s}$ in 3 axes
Resolution	0.2 mrad/s
Cutoff frequency	30 .. 50 Hz
<b>Output data</b>	
Output signal	CANopen
<b>Environmental conditions</b>	
Compensated temperature range	-20 .. +60 °C
Operating temperature range	-40 .. +85 °C
Storage temperature range	-40 .. +85 °C
CE mark	EN 61000-6-1 / 2 / 3 / 4 (see Declaration of Conformity)
Vibration resistance acc. to DIN EN 60068-2-6 at 10 .. 500 Hz	5 g (criteria B)
Shock resistance acc. to DIN EN 60068-2-27	20 g, 11 ms half sine (criterion B) 50 g, 6 ms half sine (criterion B)
Protection class <sup>2)</sup> acc. to DIN EN 60529 ISO 20653	IP66, IP67, IP69 IP6K9K
<b>Protocol data for CANopen</b>	
Communication profile	CiA DS 301 V4.2
NMT-Services	CiA DSP 302 V4.1
Layer setting services and protocol	CiA DSP 305 V2.2
Device profile	CiA DS 410 V1.3
Baud rates	10 kbit .. 1 Mbit acc. to. CiA DS305 V2.2
Transmission services	
- PDO	Measured value as 16 bit value, status
- Transfer	synchronous, asynchronous, cyclical
Node Id / Baudrate	Can be set via Manufacturer Specific Profile & LSS
Default setting	250 kbps / Node ID 1
<b>Other data</b>	
Supply voltage	9 .. 36 V DC
Residual ripple of supply voltage	< 5 %
Power consumption	< 5 W
Housing material	Aluminium, anodized
Weight	~ 400 g

Note: Reverse polarity protection of the supply voltage and overvoltage protection are provided. Sensors for applications with increased functional safety on demand.

<sup>1)</sup> e.g. approx. 40 s at 20 °C, < 2 min at 0 °C

<sup>2)</sup> With mounted mating connector in corresponding protection class

## Dimensions:

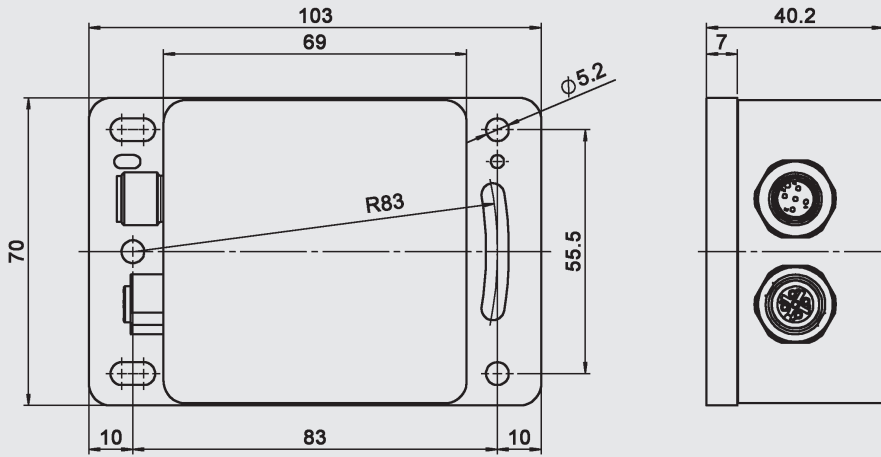

## Coordinate system and direction of rotation:

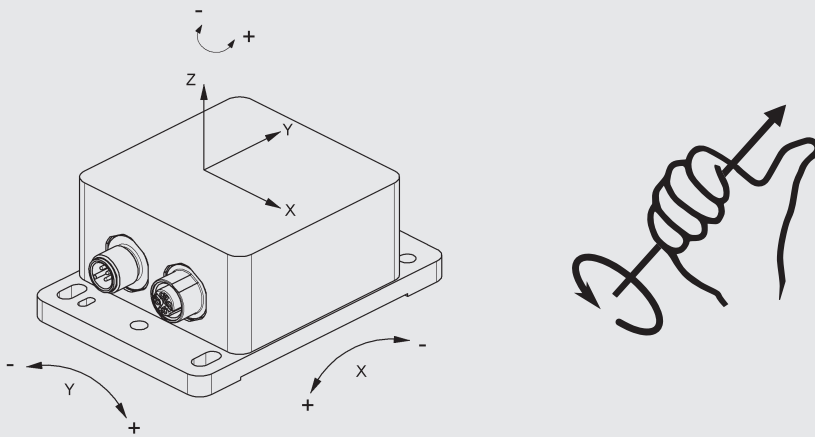

## Pin connections:

Male M12x1, 5 pole

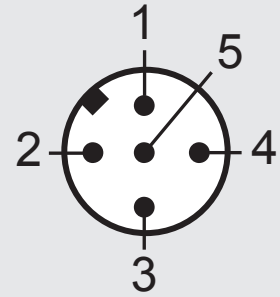

Female M12x1, 5 pole

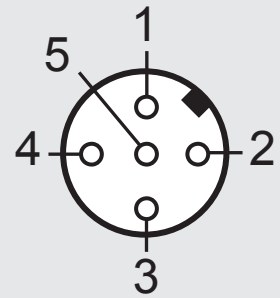

Pin	Signal	Description
1	CAN_SHLD	CAN shield
2	CAN_V+	CAN external positive supply
3	CAN_GND	Ground / 0 V / V-
4	CAN_H	CAN_H bus line (dominant high)
5	CAN_L	CAN_L bus line (dominant low)

## Model code:

HIT 1508 - F11 - X - XXX - X - XX - X - 000

### Motion compensation

5 = with

### Electrical connection

8 = male M12x1, 5 pole

### Output signal

F11 = CANopen

### Primary inclination axis (slope long)

X / Y / Z

### Measuring range rotation about primary axis in °<sup>1)</sup>

015; 060; 120; 180

### Secondary inclination axis (slope lateral)

X / Y / Z / 0 (0 = not available)

### Measuring range rotation about secondary axis in °<sup>1)</sup>

15; 60; 90; 00 (00 = axis not available)

### Additional CAN socket

0 = none

1 = female M12x1, 5 pole

### Modification number

000 = standard

### Note:

<sup>1)</sup> Other measuring ranges on request

## Note:

The information in this brochure relates to the operating conditions and applications described. For applications or operating conditions not described, please contact the relevant technical department.

Subject to technical modifications.

**HYDAC ELECTRONIC GMBH**  
Hauptstraße 27, 66128 Saarbrücken  
Germany  
Telephone +49 (0)6897 509-01  
Fax +49 (0)6897 509-1726  
E-mail: [electronic@hydac.com](mailto:electronic@hydac.com)  
Internet: [www.hydac.com](http://www.hydac.com)