

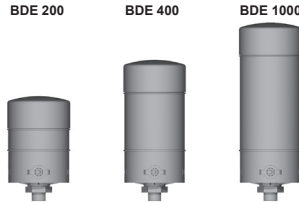

Breather Dryer BDE



1. TECHNICAL SPECIFICATIONS

1.1 DEFINITION OF THE PROBLEM

In hydraulic and lubrication systems, water ingress into the tank is a familiar problem. System operators are constantly faced with high breakdown and maintenance costs that can be traced back to water in the system. This is because water, even in its dissolved state, causes accelerated degradation of the additive components by hydrolysis. These reactions cause the oil to lose its desired characteristics and to age more rapidly. The depletion of the additives also leads to increased oxidation in the base fluid.

Water also has serious and adverse effects on the operating system components, damaging them by corrosion and hydrogen embrittlement.

1.2 FILTER HOUSING Construction

The distinctive feature of the breather dryers BDE is that it has two separate chambers which can be filled with two desiccants, which in combination increase total water retention (two-stage dewatering).

As an option, and as a special protection of the desiccant, four valves are built into the bottom of the unit so that during system shutdown the desiccants will not become saturated.

A check valve is available as an option to prevent exhaust air from the tank/ transmission from flowing back through the desiccant. This means the desiccant is protected from oil mist and there is no re-drying of the exiting air.

1.3 FILTER MEDIUM

The built-in pleated air filter element (absolute filtration of particles > 2 µm) provides the filter with a very high contamination retention capacity (26g). In order to ensure reliable function, the entire cartridge must be replaced. When the filter is due to be changed, the colour changes from dark red to light orange.

1.4 FILTER SPECIFICATIONS

Temperature range	-30 °C to +100 °C
	Storage temperature: -40 °C to +100 °C
Material of filter housing	Plastic (PA, PC and POM)
Material of filter cartridge unit	Combination of 2 different desiccants
Material of air filter element	phenolic resin impregnated paper

1.5 SEALS

NBR (= Perbunan)

1.6 SPECIAL MODELS AND ACCESSORIES

On request

1.7 SPARE PARTS

See Original Spare Parts List

1.8 CERTIFICATES AND APPROVALS

On request

1.9 COMPATIBILITY WITH HYDRAULIC FLUIDS ISO 2943

The filter cartridge actively prevents contamination particles and humidity from entering the tank. Compatible with mineral oils and bio oils as well as diesel.

The new BDE is not suitable as a breather for reservoirs containing highly flammable liquids (e.g. fuel, solvents, etc...)!

1.10 CHANGING INTERVALS

When the filter is due to be changed, the colour changes reliably from dark red to light orange.

Symbol: BDE with valves

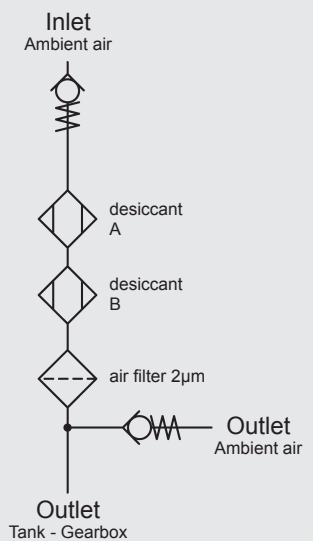

Symbol: BDE without valves

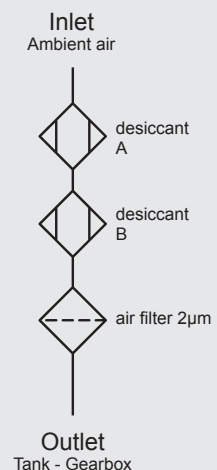

2. MODEL CODE (also order example)

BDE 400 G 2 W 1 . X /-RV0.02

2.1 COMPLETE FILTER

Filter type

BDE

Size of filter

200, 400, 1000

Type and size of connection

- F Flange (to DIN 24557)
- G Thread
- N Thread NPT
- M Thread metric
- S Slip fit

Filtration rating in µm

2 2 µm absolute

Type of clogging indicator

- W without port, no clogging indicator
- UBM vacuum indicator

Type code

Type code	Thread connection G	Thread connection N	Thread connection M	Slip fit connection S	Flange connection F
1	G1	NPT 1"	M42x2	1"	t2
2	BSP 3/4"	NPT 2"	–	–	–

Modification number

X the latest version is always supplied

Supplementary details

- ELF with filler strainer (only for connection type F = Flange)
- RV0.02 check/protection valve with 0.02 bar pressure setting
- RV0.003 check/protection valve with 0.003 bar pressure setting

2.2 REPLACEMENT CARTRIDGE

BDE 400 X 2 W 0 . X

Filter type

BDE

Size

200, 400, 1000

Connection type

X replacement cartridge

Filtration rating

2 2 µm absolute

Type of clogging indicator

- W without port, no clogging indicator
- UBM vacuum indicator

Type code

0 replacement cartridge

Modification number

X the latest version is always supplied

3. FILTER CALCULATION / SIZING

3.1 SIZING GUIDELINES

The rate at which contamination enters a hydraulic system can be considerably reduced by using efficient tank breather filtration.

CAUTION:

Incorrectly sized tank breather filters can place additional strain on the system and reduce the service life of hydraulic filter elements.

Δp-Q graph:

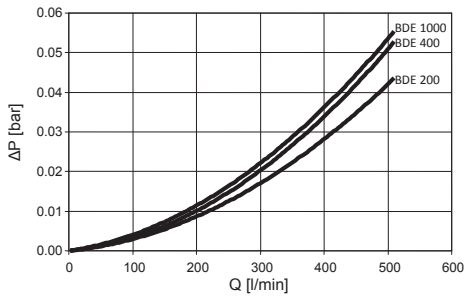

3.2 SIZING / AIR FLOW RATE

The following table indicates the size of BDE filters for gearbox lubrication in wind power plants (according to size in megawatts):

	≤ 1 MW	1-3 MW	≥ 3 MW
Standard conditions	200	400	1000
Longer service life/service intervals	400	1000	2x1000
Very humid climate	400	1000	2x1000

Additional information on sizing criteria:

Size	Optimum air flow rate * [l _{air} / min]	Max. drying capacity for average humidity [m ³ _{air}]	Max. drying capacity for high humidity [m ³ _{air}]	FOR HYDRAULIC TANKS		max. tank size with stat. venting, e.g. gears
				max. suction rate	max. tank size	
200	10	10	6	120 lpm	300 l	500 l
400	20	25	15	150 lpm	600 l	1000 l
1000	35	42	25	180 lpm	1000 l	2000 l

* Air flow rate with the highest drying efficiency

Saturation content:

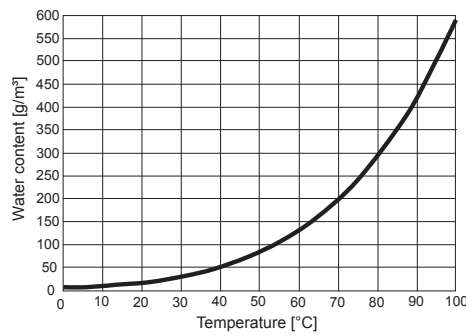

3.3 WATER RETENTION CAPACITY

Size	Maximum water retention capacity
200	0.25 l
400	0.50 l
1000	0.75 l

4. DIMENSIONS

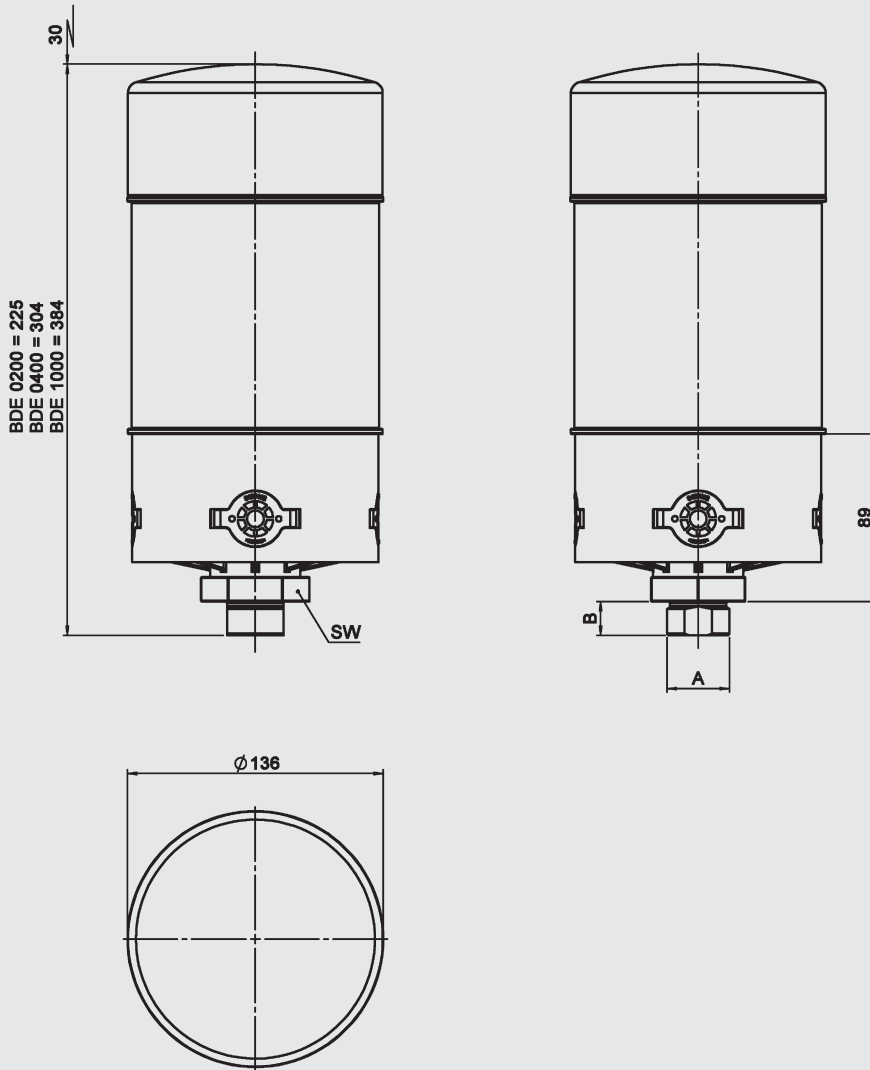

Connection	Thread length B [mm]	AF width SW [mm]
1" Slip fit connection Ø 33.4	18	50
G 1"	18	50
G 3/4"	18	50
M42 x 2	18	50
NPT 1"	18	50
NPT 2"	24	65
Flange adapter DIN24557/Pt 2	20	50

Type	Weight [kg]
BDE 200	1.7
BDE 400	2.3
BDE 1000	3.0

NOTE

The information in this brochure relates to the operating conditions and applications described.

For applications or operating conditions not described, please contact the relevant technical department.

Subject to technical modifications.