

RB Series Hose Break Valves



RB...

Housing Valves

RBE...

Cartridge Valves

Model Code

RB E - SAE1-1/16-12 - X - 120L/MIN

Hose Break Valve

Housing Type

Refer to "code" column below

Size of Connection

Refer to "Size of Connection" below

Modification Number

X = Latest Revision

Closing Flow Rate

XXXL/MIN = Standard

Max. closing flow rate listed below in l/min

XXXGPM = Factory Set

Customer specifies closing flow rate in gpm

*R threaded connections are not standard but can be specified and made available at extended lead times by visiting HYDAC.com and searching for EN 5.174.

Type and Size Codes

Code	Housing Type	Connection 1	Connection 2	Size*	Closing Flow Rate (GPM)	Closing Flow Rate (L/min)	HYDAC P/N	HYDAC Model Code
E		-	-	SAE 9/16-18	1-4	4-15	710031	RBE-SAE 9/16-18-X-15LPM STD. SET
				SAE 3/4-16	1.6-12	6-45	710032	RBE-SAE 3/4-16-X-45LPM STD. SET
				SAE 1 1/16-12	6.5-32	25-120	710033	RBE-SAE 1-1/16-12-X-120LPM STD. SET
XB		SAE Straight Thread Port	SAE Straight Thread Stud End	SAE 9/16-18	1-4	4-15	2069016	RBXB-SAE 9/16-18-X-15LPM STD. SET
				SAE 3/4-16	1.6-12	6-45	2062157	RBXB-SAE 3/4-16-X-45LPM STD. SET
				SAE 1 1/16-12	6.5-32	25-120	2061898	RBXB-SAE 1-1/16-12-X-120LPM STD. SET
XB		NPT Port	NPT Male Connector	NPT 3/8	1-4	4-15	2062818	RBXB-NPT 3/8-X-15LPM STD. SET
XX		SAE Straight Thread Port	SAE Straight Thread Port	SAE 1 1/16-12	6.5-32	25-120	2063213	RBXX-SAE 1-1/16-12-X-120LPM STD. SET
CC		NPT Male Connector	NPT Male Connector	NPT 3/4	1.6-12	6-45	2062871	RBE-NPT 3/4-X-45LPM STD. SET

* Dependent on Desired Closing Flow Rate

** Other sizes may be available at extended lead times. Contact Accessories.ATS@HYDAC-NA.com.

Hydraulic Symbol

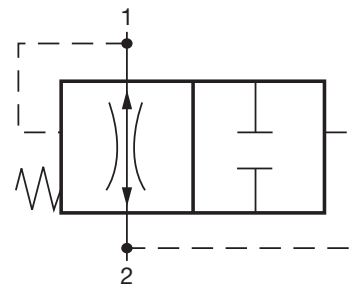

1-2 Free Flow
2-1 Operating Direction;
Valve closes if flow exceeds
adjusted flow rate.

Description

HYDAC Hose Break Valves eliminate uncontrolled movements of the actuator in case of line rupture. They are commonly applied with dead weight cylinders.

These valves are volume limiting flat seat valves.

At normal flow, the poppet is held open by a spring with enough force to counteract the force on the poppet created by the flow.

When the supply line is ruptured, the flow from 2 to 1 exceeds the specified flow rate, the P across the poppet creates a force greater than the spring force and closes the valve. This closing flow rate is adjustable. The valve opens automatically by pressurizing connection 1.

Depending on the pressure P, the leakage rate through the valve is approximately 0 to 6 in³ / min. If this is excessive, the valve threads can be sealed and made leak-free.

The valves are installed between actuators and possible line breakage points.

A cartridge-type valve can be installed into an actuator port.

A housing-type valve can be installed close to the actuator or even directly into the actuator itself.

Closing Flow Rate (min - max) (from 2 to 1)	
To avoid the activation of hose break valves on flow surges, the closing flow rate should be at least 20% above the normal flow rate.	Valves are shipped with maximum closing flow setting. Closing flow can be adjusted according to the curve on the next page. If closing flow must be set by factory, please specify when ordering.

FLOW CONTROL VALVES

Adjustment Curves for Closing Flow Rate

The closing flow rate is dependent on the dimensions "H".

After loosening the lock nut, set the GAP to dimension "H" with a thickness gauge.

The lock nut must be tightened after adjustment.

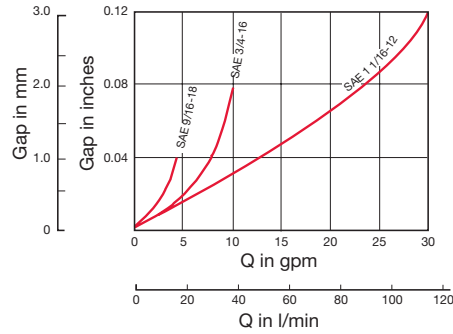
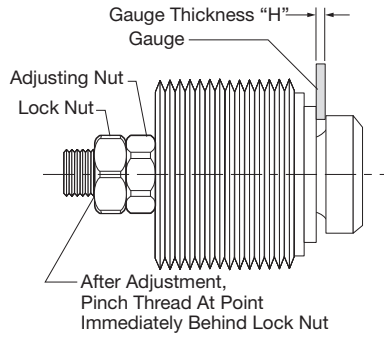

The adjustment curves are valid for cartridge RBE...and for all housing valves RB... in accordance with "Type and Size Codes" charts on previous page. For model RB... the cartridge must be removed from the housing for adjustment.

See special tool for installation and removal on page A5-19.

Dimensions

Cartridges

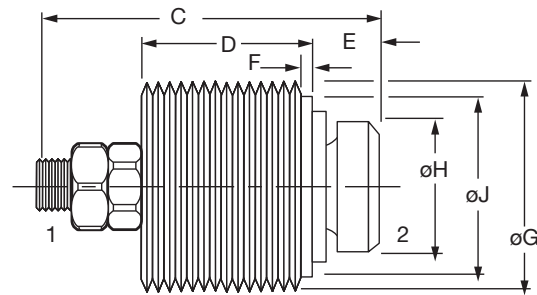
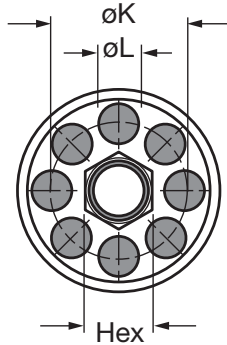

Valve Type	C	D	E	F	øG	øH	øJ	øK	øL	Hex
RBE-SAE 9/16	0.866 (22)	0.453 (11.5)	0.138 (3.5)	0.13 (3)	9/16-18UNF-2B	0.374 (9.5)	0.460 (11.7)	0.315 (8)	0.098 (2.5)	0.197 (5)
RBE-SAE 3/4	1.063 (27)	0.531 (13.5)	0.197 (5)	0.14 (3.5)	3/4-16UNF-2B	0.472 (12)	0.640 (16.3)	0.394 (10)	0.138 (3.5)	0.217 (5.5)
RBE-SAE 1 1/16	1.614 (41)	0.925 (23.5)	0.256 (6.5)	0.17 (4)	1 1/16-12UNF-2B	0.709 (18)	0.930 (23.6)	0.630 (16)	0.256 (6.5)	0.276 (7)

Notes:

1. Dimensions are in inches (mm) and lbs (kg).

2. Dimensions are for general information only, all critical dimensions should be verified by requesting a certified print.

Dimensions

RBXX-SAE 1-1/16-12

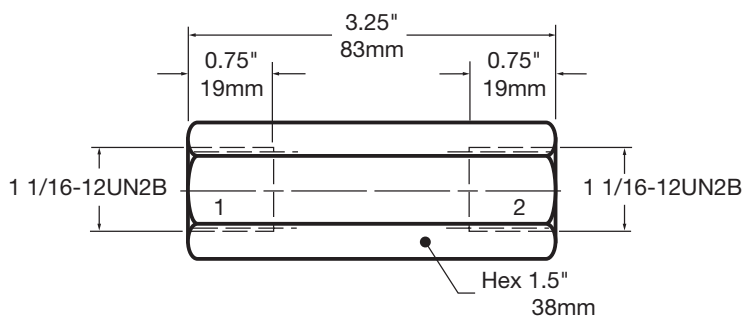

RBCC-NPT 3/4 Housing Valve

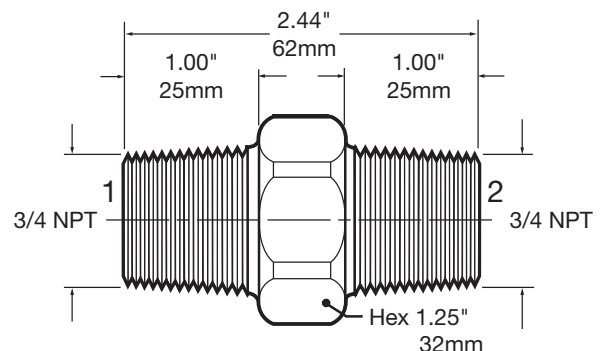

Dimensions

RBXB... SAE

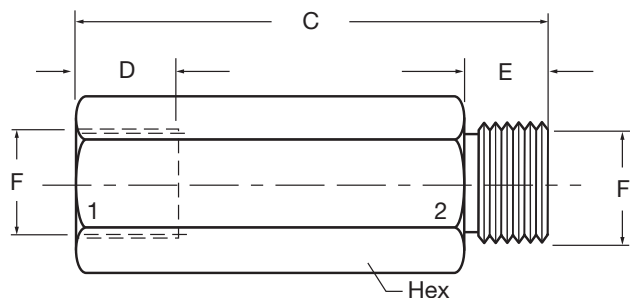

RBXB... NPT

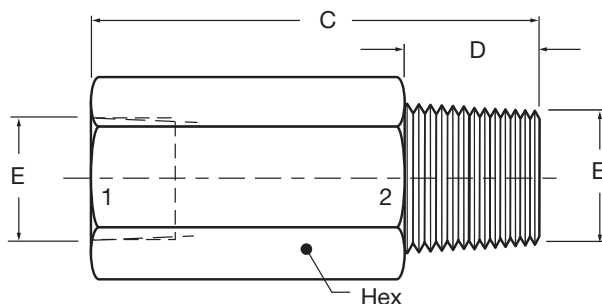

Housing Type	C	D	E	F	Hex
RBXB-SAE 9/16-18	2.13 (54)	0.50 (13)	0.39 (10)	9/16-18UNF-2B	0.75 (19)
RBXB-SAE 3/4-16	2.38 (60)	0.56 (14)	0.44 (11)	3/4-16UNF-2B	1.00 (25)
RBXB-SAE 1 1/16-12	3.25 (83)	0.75 (19)	0.59 (15)	1 1/16-12UNF-2B	1.50 (38)
RBXB-NPT 3/8	2.09 (53)	0.59 (15)	3/8 NPT		0.88 (22)
RBXB-NPT 1/2	2.75 (70)	0.78 (20)	1/2 NPT		1.00 (25)
RBXB-NPT 1	3.31 (84)	0.98 (25)	1 NPT		1.75 (44)

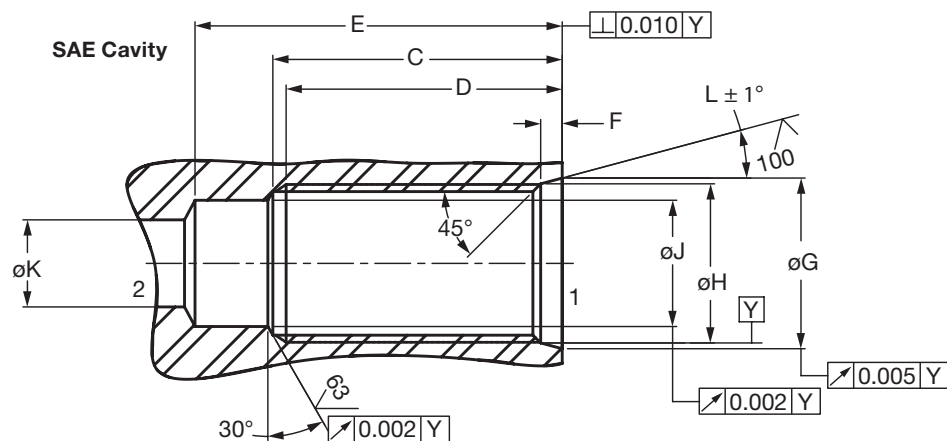

Housing Type	C	D	E	F	øG	øH	øJ	øK Min	L
RBE-SAE 9/16	1.250	1.188	1.56	0.106	0.618	9/16"-18UNF-2B	0.435	0.297	12°
RBE-SAE 3/4	1.375	1.312	1.69	0.106	0.813	3/4"-16UNF-2B	0.600	0.422	15°
RBE-SAE 1 1/16	2.000	1.938	2.44	0.138	1.150	1-1/16"-12UN-2B	0.890	0.609	15°

Notes:

1. Dimensions are in inches (mm) and lbs (kg).

2. Dimensions are for general information only, all critical dimensions should be verified by requesting a certified print.

Nominal Flow Curves

Flow rate is dependent on operating setting "H". See "Adjusting Curves for Closing Flow Rates - Settings". Curves are valid for Cartridges RBE and Housing RB... in accordance with charts on previous page. Limit Lines indicate the maximum closing flow rates. These rates cannot be exceeded. Curves were established at 150 SUS.

RBE-SAE 9/16 - 18

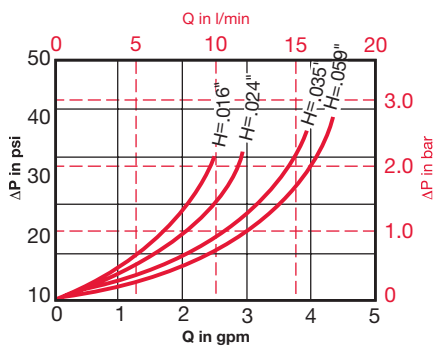

RBE-SAE 3/4 - 16

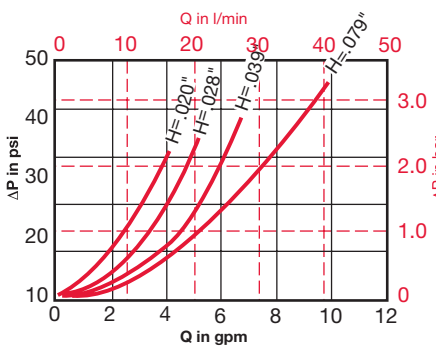

RBE-SAE 1-1/16 - 12

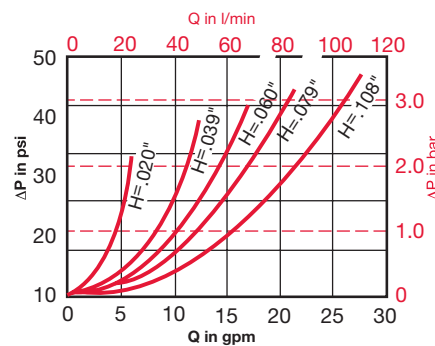

FLOW CONTROL VALVES

Engineering Data

Design	Flat Seat Valve	
Mounting Method	RBE	Cartridge
	RB..	Housing Valve for In-line Installation
Connection	Refer to chart on page A5-16	
Mounting Position	Optional	
Direction of Flow	1 to 2	Free Flow
	2 to 1	Free Flow; valve automatically closes if flow exceeds preset level
Fluid	General purpose hydraulic oil. Consult HYDAC for other media	
Operating Pressure Ratings	P Max:	5000 psi (350 bar)
	P Min:	145 psi / 10 bar
Fluid Temperature Range	-4° to 176°F (-20° to 80°C)	
Material	Carbon Steel	

Weights

RBE	lbs.
SAE 9/16-18	0.02
SAE 3/4-16	0.04
SAE 1 1/16-12	0.13
RBXB	lbs.
SAE 9/16-18 3/8 NPTF	0.17
SAE 3/4-16 1/2 NPTF	0.24
SAE 1 1/16-12 1 NPTF	0.88
RBXX	lbs.
SAE 1 1/16-12	0.92
RBCC	lbs.
3/4 NPTF	0.37

Recommendations

Hose break valves, type RBE must only be used to safeguard users in the event of hose breaks. They must not be used as switching valves for repeated closing actions.

If closing actions occur during normal operation, the setting of the hose break valve is not suitable for the operating parameters of the system. The hose break valve must be replaced by a new one with a modified setting.

In order to prevent hose break valves reacting to flow rate fluctuations inherent in the system, e.g. due to switching of directional valves, the actuating flow rate should be at least 20% above the normal maximum system flow rate. If high viscosity fluctuations occur, the valves must be set to a higher actuating flow rate to ensure trouble-free operation at high viscosity. However, the valves must still react at a low viscosity. Since this range depends largely on the system, whose operational flow rate fluctuations can also depend on viscosity, the appropriate setting for the valve is best determined on site.

Sizing Hose Break Valves

In order for a hose break valve to work properly there must be a difference between the normal operating flow rate (from pump) and the emergency flow rate created by a hose or line break. The emergency flow rate must be significantly higher than the normal operating flow. Why? The hose break valve is designed to only be closed in an emergency situation. These valves should not be cycled (opened and closed) with the system. Cycling the valve and/or excessive vibrations will lead to premature failure of the valve components.

How do you determine the emergency flow rate? You must perform a test with the actual system in a hose break simulation. This test should be run with the minimum load on the cylinder/lift to determine the minimum emergency flow rate for the system. To test, break the line open or open a directional valve and allow gravity to pull down the cylinder/lift. The flow rate measured during this test is the emergency flow rate.

The hose break closing flow rate setting is adjustable and should be set to close at a flow rate between the normal flow rate and the emergency flow rate. The closing flow rate should be set at least 20% higher than the normal flow rate, and should be set at least 20% below the emergency flow rate.

How do you set the closing flow rate for the valve? The gap between the poppet and the valve body is adjustable by means of the lock nut and adjustment nut on the end of the poppet. The larger the gap, the higher the closing flow rate for the valve.

Installation Tools

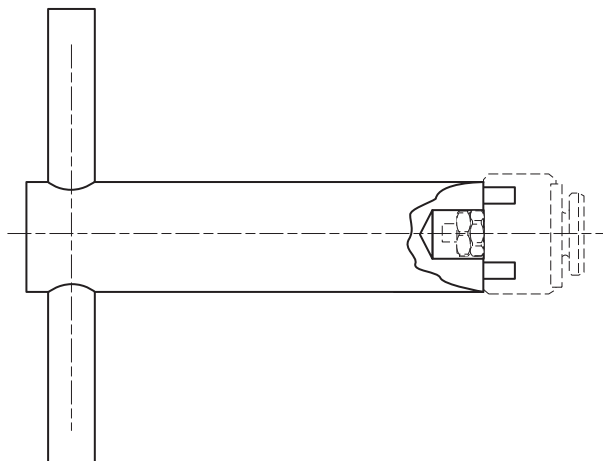

Cartridge Size	Part Number
9/16-18	00161421
3/4-16	00160561
1-1/16-12	00164180

AEV Series

Automatic Air Vent Valves



Model Code

AEV - 6 / 5

Part Number

00230223

Mounting

The inlet port is connected to the pressure line and the outlet port should be connected back into the non-pressurized reservoir.

For ventilation of pumps the valve should be mounted adjacent to the pump outlet. For system ventilation the valve should be mounted at the system's highest point.

Description

The HYDAC Air Vent Valve eliminates air bubbles which accumulate in hydraulic systems immediately after start-up or after long periods of shut-down of the system.

The Air Vent Valve remains open until the valve reaches a 45 psi differential pressure.

Pressure must be maintained above 45 psi to keep valve closed.

This type of operation of the HYDAC Air Vent Valve allows for easy start-up of hydraulic systems.

Due to the compact design the Air Vent Valve requires minimum space.

Technical Data

Operating Pressure Range

- P min 43 psi (3 bar)
- P max 8700 psi (600 bar)

Material

- Carbon Steel

Operating Flow Range

- Q min 0.25 gpm (1 l/min)
 - Q max 15 gpm (57 l/min)
- to achieve higher flow rates, parallel connection is possible

Mounting Positions

Optional - see figures A and B.

The return line must be connected to reservoir below the minimum oil level.

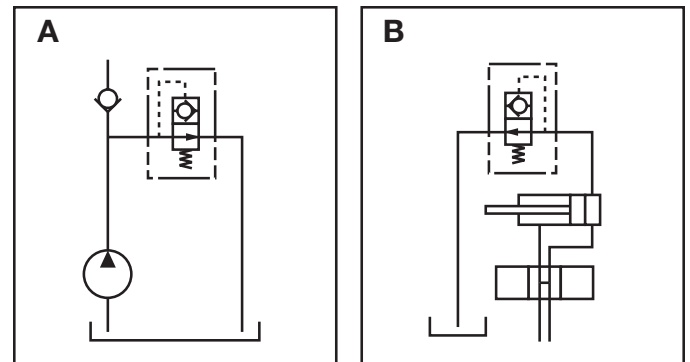

Dimensions

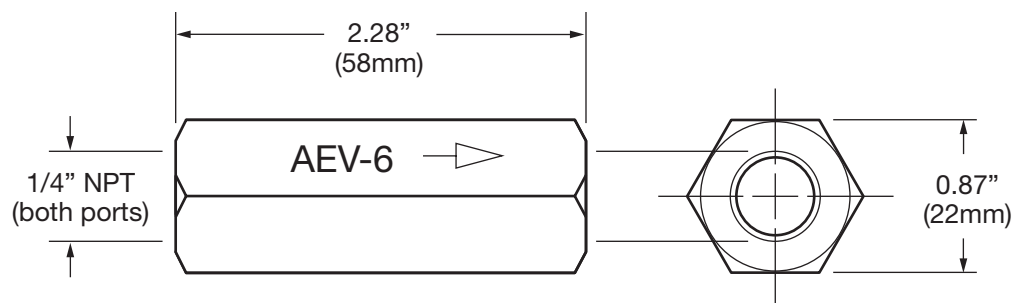

Notes:

1. Dimensions are in inches (mm).
2. Dimensions are for general information only, all critical dimensions should be verified by requesting a certified print.

FLOW CONTROL VALVES

Notes

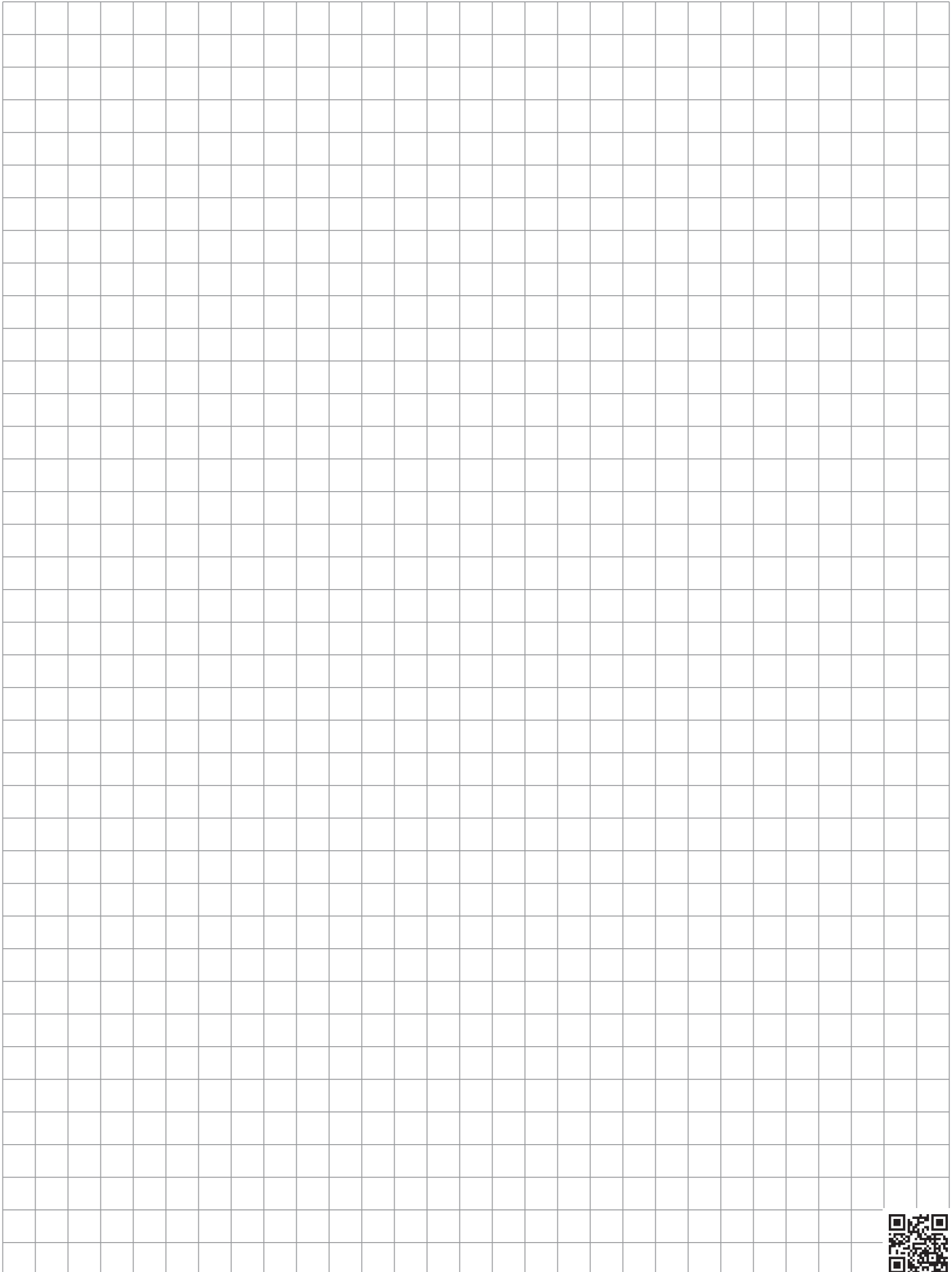
A large grid of graph paper for taking notes, consisting of 20 columns and 30 rows of small squares.