

HIGH PRESSURE BALL VALVES

Seal Kits

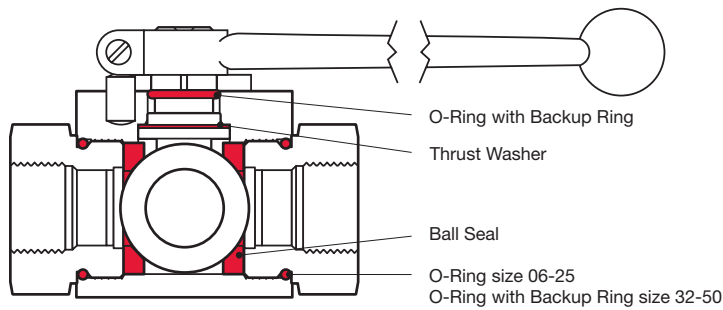

Model Code

SEAL KIT KHB - 06 NPT/SAE - XX14

Seal Kit _____

Valve Body Type _____

- KHB = Block Housing
- KHM = Forged Housing
- KH3/4 = 3-Way & 4-Way Valves
- KHP = Manifold Mount

Valve Size _____

06, 10, 16, 20, 25, 32, 40,50

Connection Type _____

(omit) = Manifold Mount (KHP)
 NPT/SAE = NPT or SAE
 F3/F6 = F3 or F6 Split Flange

Materials _____

Body Material _____

X = Body material does not affect seal kits

Spindle and Ball Material _____

X = Spindle and ball material does not affect seal kits

Ball Seal Material _____

1 = Polyacetal (standard)
 3 = PTFE
 8 = PEEK

O-Ring Material _____

2 = NBR (Buna N)
 3 = PTFE Spindle Seals and FPM (Fluoroelastomer)

O-Rings _____

4 = FPM (Fluoroelastomer) (standard)
 5 = EPDM

Model Code	Part Number
SEAL KIT KHB-06NPT/SAE-XX14	02061479
SEAL KIT KHB-10NPT/SAE-XX14	02061467
SEAL KIT KHB-16F3/F6-XX14	02061469
SEAL KIT KHB-16NPT/SAE-XX14	02061468
SEAL KIT KHB-20F3/F6-XX14	02061471
SEAL KIT KHB-20NPT/SAE-XX14	02061470
SEAL KIT KHB-25F3/F6-XX14	02061473
SEAL KIT KHB-25NPT/SAE-XX14	02061472
SEAL KIT KHM-32F3/F6-XX14	02061481
SEAL KIT KHM-32NPT/SAE-XX14	02061480
SEAL KIT KHM-40F3/F6-XX14	02061483
SEAL KIT KHM-40NPT/SAE-XX14	02061482
SEAL KIT KHM-50F3/F6-XX14	02061485
SEAL KIT KHM-50NPT/SAE-XX14	02061484
SEAL KIT KHP-06-XX14	00554029
SEAL KIT KHP-10-XX14	02061486
SEAL KIT KHP-16-XX14	02061487
SEAL KIT KHP-20-XX14	02061507
SEAL KIT KHP-25-XX14	02061488
SEAL KIT KHP-32-XX14	02061489
SEAL KIT KHP-40-XX14	02061505
SEAL KIT KHP-50-XX14	02061506

Complete maintenance instructions are available on our web site:
<http://www.hydac-na.com/sites/hydac-na/Downloads/Manuals/Accessories>

www.HYDAC-NA.com

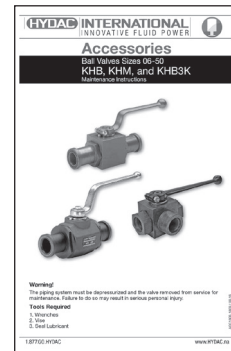

Handles

DN Sizes	Description	Handle Code	Spindle Sq. Size	Model Code	Part Number
06, 10	Straight Aluminum	11X	SW09	HANDLE STR AL SW09	00270099
06, 10	Offset Aluminum	12X	SW09	HANDLE OFS AL SW09	00271423
06, 10	Offset Steel	16X	SW09	HANDLE KIT OFS STL SW09	02064265*
06,10	Wing Steel	20X	SW09	HANDLE KIT WING TYPE STL SW09 20X	2210360*
16	Straight Aluminum	11X	SW12	HANDLE STR AL SW12	00270100
16	Offset Aluminum	12X	SW12	HANDLE OFS AL SW12	00270381
16	Offset Steel	16X	SW12	HANDLE KIT OFS STL SW12	02064266*
16	Wing Steel	20X	SW12	HANDLE KIT WING TYPE STL SW12 20X	2206497*
20, 25	Straight Aluminum	11X	SW14	HANDLE STR AL SW14	00270101
20, 25	Offset Aluminum	12X	SW14	HANDLE OFS AL SW14	00270382
20, 25	Offset Steel	16X	SW14	HANDLE KIT OFS STL SW14	02064267*
20,25	Wing Steel	20X	SW14	HANDLE KIT WING TYPE STL SW14 20X	2210361*
32, 40, 50	Offset Steel	16X	SW17	HANDLE KIT OFS STL SW17 16X	02064268*
32, 40, 50	Offset Aluminum	12X	SW17	HANDLE OFS AL SW17	00270383
32, 40, 50	Straight Aluminum	11X	SW17	HANDLE STR AL SW17	00270311
	No Handle	09X			
	Loose Handle	0XX			

*These handles require the additional mounting hardware which is included