

2/2-way coaxial valve CX06M to CX08M pilot operated

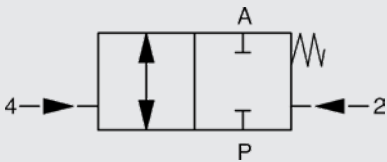

Switching function



NC (closed when de-energised)

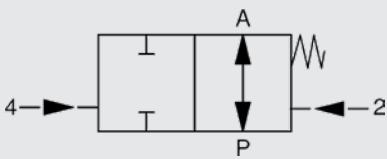

NO (open when de-energised)

Order data

- Nominal size
- Connection
- Function NC/NO
- Operating pressure
- Flow rate
- Medium
- Medium temperature
- Ambient temperature
- Supply voltage
- Number of module blocks

If order details or application data are inaccurate or incomplete, there is a risk that the technical configuration of the valves may not be correct for the desired use. This may result in the physical and/or chemical characteristics of the materials or seals used not being adequate for the intended use.

Model code (also example order)

CX06M 2/2 F C 2 10 064 014 PV

Designation

CX06M = modular series CX06M
CX07M = modular series CX07M
CX08M = modular series CX08M

Ways

2/2 = number of ways

Control

F = external pilot

Switching function

C = NC - closed when de-energised
O = NO - open when de-energised*

Body material

2 = brass (valve), aluminium (block)

Nominal size

10 = DN 10
15 = DN 15
20 = DN 20
25 = DN 25
32 = DN 32
40 = DN 40
50 = DN 50

Pressure range

064 = CX06M > 0 - 64 bar
120 = CX07M > 0 - 120 bar
160 = CX08M > 0 - 160 bar

Connection

014 = G $\frac{1}{4}$ - DN 10
038 = G $\frac{3}{8}$ - DN 10, DN 15
012 = G $\frac{1}{2}$ - DN 10, DN 15, DN 20
034 = G $\frac{3}{4}$ - DN 15, DN 20, DN 25
100 = G1 - DN 20, DN 25, DN 32
114 = G1 $\frac{1}{4}$ - DN 25, DN 32
112 = G1 $\frac{1}{2}$ - DN 32, DN 40
200 = G2 - DN 50

Option

PV... = pilot valve (... acc. to accessories)

*optional

Technical specifications

Control	2/2-way valve, pilot operated		
Nominal size	DN10 to DN50		
Pressure range (see table)	CX06M	DN 10 to DN 50	PN 0 to PN 64
	CX07M	DN 10 to DN 25	PN 0 to PN 120
	CX07M	DN 32 to DN 50	PN 0 to PN 100
	CX08M	DN 10 to DN 25	PN 0 to PN 160
Connections	Valve:	G $\frac{1}{4}$ - G2	
	Block:	G $\frac{1}{2}$ - G2 $\frac{1}{2}$	
Body material	Single valve:	brass	
	Block:	aluminium	
Material of seals	Static:	FKM	
	Dynamic:	FKM / CX06M	
		PTFE / CX07M, CX08M	
	Seat seal:	PTFE	
Back-pressure resistant	Up to 16 bar		
Vacuum	Leakage rate < 10 ⁻⁶ mbar•l/s *		
Media	Gaseous, liquid, contaminated		
Abrasive operating fluids	On request		
Direction of flow	P → A as marked		
	A → P max. 16 bar		
Temperature of medium	-10 °C to +100 °C		
Ambient temperature	-10 °C to +50 °C		
Actuating part	Dual acting piston with return spring		
Mounting position	No orientation restrictions		
Limit switch	Magnetic field sensor		
Fixing	Mounting bracket*		

Pneumatic part (for pilot valve option)

Control	5/2-way pilot valve
Mounting pattern	Namur
Control pressure	3 to 8 bar
Air requirement	approx. 7 cm ³ / stroke
Pilot ports 2+4	G $\frac{1}{8}$ at DN10
	G $\frac{1}{4}$ at DN15 to DN50
Switching speed	CX valve can be adjusted steplessly by adjusting the supply to the pilot valve
Switching times	Open/close 50 - 1000 ms depending on control pressure, pilot valve (option) and exhaust air throttle (option)

Electrical part (for pilot valve option)

Supply voltage	DC: 24 V
	AC: 230 V 40-60 Hz
Electrical part	DC: DC magnet
	AC: DC magnet with integrated rectifier
Connection	Connector plug to industrial standard, model B
	Connector plug to DESINA M12x1 *
	Connector with LED (transparent housing) with varistor*
Voltage tolerance	±10 % to VDE 0580
Duty cycle	100 % duty cycle
Protection class	IP 65 when fitted with connector plug

 The material specification refers exclusively to the valve connection parts in contact with the medium. *optional

 The valves are technically configured for specific media and applications. This may result in deviations from the general information given in the data sheet in terms of the design, sealing materials and specifications.





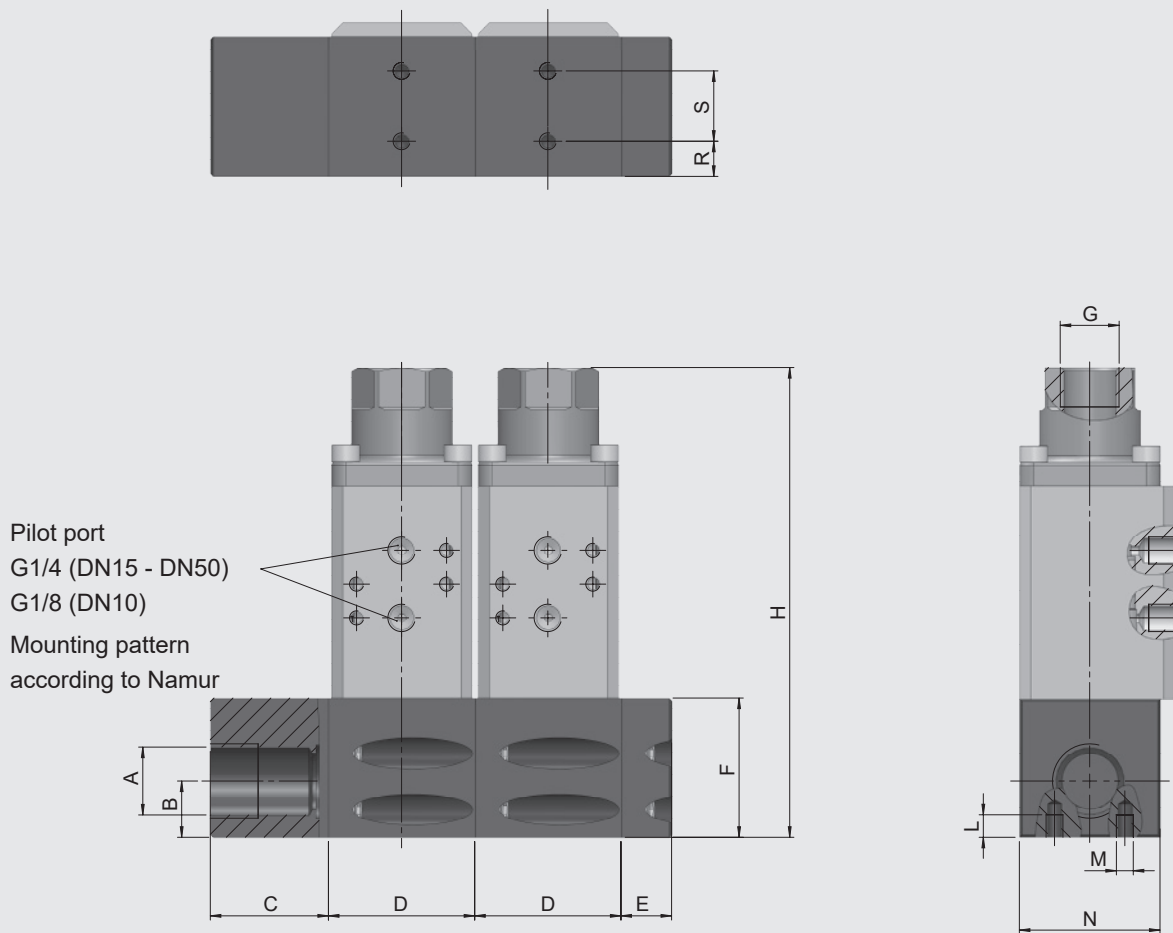

Series	DN [mm]	Pressure [bar]	Connection	Kv value [m ³ /h]	Weight [kg]
CX06M	10	0 - 64	G ¹ / ₄ , G ³ / ₈ , G ¹ / ₂	2.7	1.5
	15	0 - 64	G ³ / ₈ , G ¹ / ₂ , G ³ / ₄	7.2	3.2
	20	0 - 64	G ¹ / ₂ , G ³ / ₄ , G1	9.4	4.0
	25	0 - 64	G ³ / ₄ , G1, G1 ¹ / ₄	14.5	5.3
	32	0 - 64	G1, G1 ¹ / ₄ , G1 ¹ / ₂	20.0	6.9
	40	0 - 64	G1 ¹ / ₂	45.7	11.7
	50	0 - 64	G2	47.2	11.7
CX07M	10	0 - 120	G ¹ / ₄ , G ³ / ₈ , G ¹ / ₂	2.7	1.5
	15	0 - 120	G ³ / ₈ , G ¹ / ₂ , G ³ / ₄	7.2	3.2
	20	0 - 120	G ¹ / ₂ , G ³ / ₄ , G1	9.4	4.0
	25	0 - 120	G ³ / ₄ , G1, G1 ¹ / ₄	14.5	5.3
	32	0 - 100	G1, G1 ¹ / ₄ , G1 ¹ / ₂	20.0	6.9
	40	0 - 100	G1 ¹ / ₂	45.7	11.7
	50	0 - 100	G2	47.2	11.7
CX08M	10	0 - 160	G ¹ / ₄ , G ³ / ₈ , G ¹ / ₂	2.7	1.5
	15	0 - 160	G ³ / ₈ , G ¹ / ₂ , G ³ / ₄	7.2	3.2
	20	0 - 160	G ¹ / ₂ , G ³ / ₄ , G1	9.4	4.0
	25	0 - 160	G ³ / ₄ , G1, G1 ¹ / ₄	14.5	5.3

Dimensions

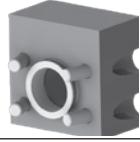
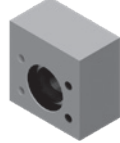
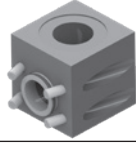
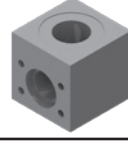
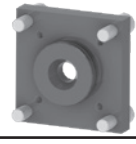
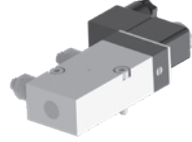
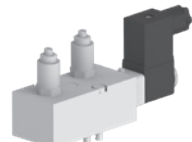
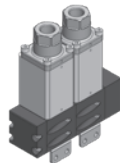

DN	A	B [mm]	C [mm]	D [mm]	E [mm]	F [mm]	H [mm]	G	L [mm]	M [mm]	N [mm]	R [mm]	S [mm]
10	G $\frac{1}{2}$, G $\frac{3}{4}$, G1	20	42	52	18	49.5	167	G $\frac{1}{4}$, G $\frac{3}{8}$, G $\frac{1}{2}$	8	M6	50	13	25
15	G $\frac{1}{2}$, G $\frac{3}{4}$, G1, G1 $\frac{1}{4}$	28	42	72	27	69.5	207	G $\frac{3}{8}$, G $\frac{1}{2}$, G $\frac{3}{4}$	8	M6	70	21	28
20	G1, G1 $\frac{1}{4}$, G1 $\frac{1}{2}$	34	32	82	32	79.5	235	G $\frac{1}{2}$, G $\frac{3}{4}$, G1	10	M8	80	25	34
25	G1, G1 $\frac{1}{4}$, G1 $\frac{1}{2}$	36	32	92	32	89.5	265	G $\frac{3}{4}$, G1, G1 $\frac{1}{4}$	10	M8	90	20	50
32	G1 $\frac{1}{4}$, G1 $\frac{1}{2}$, G2	44	34	93	34	99.5	287	G1, G1 $\frac{1}{4}$, G1 $\frac{1}{2}$	10	M8	90	21	50
40	G1 $\frac{1}{2}$, G2, G2 $\frac{1}{2}$	58	40	132	40	129.5	339	G1 $\frac{1}{2}$	21	M12	130	30	70
50	G1 $\frac{1}{2}$, G2, G2 $\frac{1}{2}$	58	40	132	40	129.5	339	G2	21	M12	130	30	70

Accessories

Joining parts	Separating plate		
	Spacer		
End caps	End cap, right		
	End cap, left		
Connection block	Connection block, right		
	Connection block, left		
	Connecting block right angled version G1 on top DN10		
	Connecting block left angled version G1 on top DN10		
Reducing adapter	Reducing adapter	DN15 to DN10 DN25 to DN10 DN25 to DN15 DN32 to DN20	
5/2-way pilot valve (NAMUR)	To use flange connection connections at side 24 V DC 230 V 50 Hz		
5/2-way pilot valve (NAMUR)	To use flange connection connections on top 24 V DC 230 V 50 Hz		
Mounting bracket			

We would be happy to discuss your requirements for further options and accessories.

Examples of ordering codes

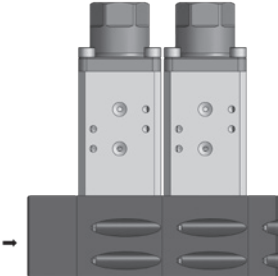
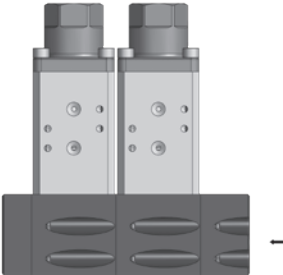
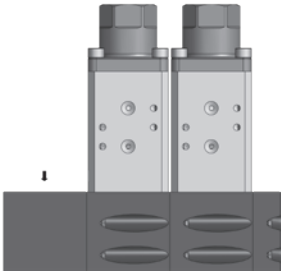
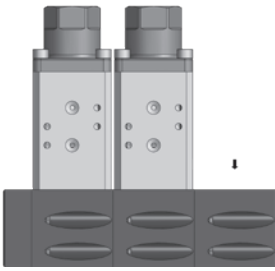
	<p>Basic valve</p>	<p>CX06M-2/2-F/C-2/10/064/014/24V</p>
	<p>Connecting block, left</p>	<p>CX06M-2/2-F/C-2/10/064/014/24V - 2XL</p>
	<p>Connecting block, right</p>	<p>CX06M-2/2-F/C-2/10/064/014/24V - 2XR</p>
	<p>Connection block, left 90° angled version, outlet on top</p>	<p>CX06M-2/2-F/C-2/10/064/014/24V - 2XLO</p>
	<p>Connection block, right 90° angled version, outlet on top</p>	<p>CX06M-2/2-F/C-2/10/064/014/24V - 2XRO</p>

NOTE

The information in this brochure relates to the operating conditions and applications described. For applications and operating conditions not described, please contact the relevant technical department.

The operator is always responsible for determining the product suitability for the specific application. Quantified values for product characteristics are average values for a new product that undergo a time deterioration process.

Subject to technical modifications and errors.

HYDAC Accessories GmbH

Hirschbachstr. 2

66280 Sulzbach/Saar

Tel.: +49 (0)6897 - 509-01

Fax: +49 (0)6897 - 509-1009

Internet: www.hydac.com

E-Mail: accessories@hydac.com