

# DIAPHRAGM ACCUMULATORS

## SBO Series

### Diaphragm Accumulators



#### Description

Diaphragm accumulators are a cost effective option for numerous functions involving energy storage, shock absorption or pulsation dampening in a hydraulic or fluid system. They are well suited for applications where smaller fluid volumes and flow rates are adequate and that require or involve:

- Compact design
- Low weight
- Flexible mounting positions
- Extremely quick shock response
- Low cost
- Low lubricity fluids, like water

Diaphragm Accumulators have been successfully applied in both industrial and mobile applications for energy storage, maintaining pressure, leakage compensation, and vehicle hydraulic systems.

HYDAC manufactures two types of diaphragm accumulators:

- Non-repairable (welded)
- Repairable (threaded)

#### Construction

Both types of diaphragm accumulators have the same basic construction. The difference is in the shell. The welded version has a shell that is electron-beam welded, and therefore cannot be repaired. The threaded type has a shell made up of two halves (*top and bottom*) which are held together by a threaded locking ring.

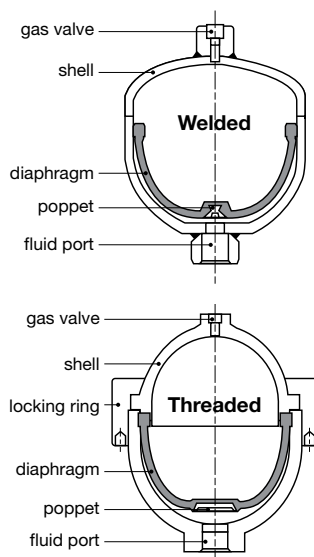

#### Diaphragm Materials

Not all fluids are compatible with every elastomer at all temperatures, therefore, HYDAC offers the following materials:

- NBR (*Standard Nitrile*)
- LT-NBR (*Low Temperature Nitrile*)
- ECO 30 (*Epichlorohydrin*)
- IIR (*Butyl*)
- FPM (*Fluoroelastomer*)
- others (*available upon request*)

*To determine which material is appropriate, always refer to fluid manufacturer's recommendation.*

#### Corrosion Protection

For use with certain aggressive or corrosive fluids, or in a corrosive environment, HYDAC offers protective coatings and corrosive resistant materials (*i.e. stainless steel*) for the parts that interface with the fluid or are exposed to the hostile environment.

#### Mounting Position

Diaphragm accumulators are designed to mount in any position. In systems where contamination is a problem, we recommend a vertical mount with the fluid port oriented downward.

#### System Mounting

HYDAC diaphragm accumulators are designed to be screwed directly onto the system. We also recommend the use of our mounting components, (detailed on page H21) to minimize the risk of failure due to system vibrations.

#### Applications

Some common applications of diaphragm accumulators are:

- Agricultural Machinery & Equipment
- Forestry Equipment
- Machine Tools
- Mining Machinery & Equipment
- Mobile & Construction Equipment
- Off-Road Equipment

For specific examples of applications using diaphragm accumulators, please see pages I2 and I3.

## Model Code

**SBO 210 - 1 E4 / 112 S - 210 CK XXX**

### Series

SBO XXX = Diaphragm Accumulator (XXX = series designation)  
(see tables on following pages for most common series and size selections)

### Size (in Liters, see tables on dimension pages to follow)

0.075 = 0.075 Liters  
...see tables on following pages for complete list of sizes, and which versions they are available in  
3.5 = 3.5 Liters

### Shell Construction and Gas Port Design

E1 = Welded Construction, rechargeable, HYDAC Gas Valve Version 1 (M 28 x 1.5)  
E2 = Welded Construction, factory precharged and sealed, (not rechargeable)  
(Not available on SBO330 or on any accumulator larger than 1.4 liters)  
E4 = Welded Construction, rechargeable, HYDAC Gas Valve Version 4 (8VI-ISO 4570)  
E9 = Welded Construction, rechargeable, Special Gas Valve  
A6 = Threaded Construction, rechargeable, HYDAC Gas Valve Version 1 (M 28 x 1.5)

### Material Code

#### Depending on Application

112 = Standard for oil service (mineral oil)

#### Fluid Port

1 = Carbon steel  
3 = Stainless steel  
4 = Chemically plated carbon steel (ONLY WETTED SURFACES for water service)  
6 = Low temperature carbon steel (< -20°F)

#### Shell

0 = Synthetic coated carbon steel (Applied internally & externally for water service)  
1 = Carbon steel  
2 = Chemically plated carbon steel (internal & external for water service)  
4 = Stainless steel (please note: MAWP decreases for most stainless models - see tables)  
6 = Low temperature carbon steel (< -20°F)

#### Diaphragm Compound

2 = NBR (Buna N)  
3 = ECO (Hydrin)  
4 = IIR (Butyl)  
5 = LT-NBR (low temp. Buna)  
6 = FPM (fluoroelastomer)  
7 = Others (available on request)

Compound	Oper. Temp Range	Typical Fluids
NBR	5° to 180°F	mineral oils
	32° to 180°F	water & water-glycols (5% minimum glycol)
Low Temp NBR	-50° to 180°F	mineral oils
ECO...113...	-20° to 250°F	mineral oils
ECO...663...	-40° to 250°F	mineral oils & water (with low temperature CS shell)
IIR	-20° to 200°F	phosphate esters & brake fluids
FPM	5° to 300°F	chlorinated hydrocarbons

#### Country of Installation

S = USA  
(for other countries see page A3 for proper code designation)

#### Maximum Working Pressure in bar (see tables on dimension pages to follow)

100 = 1500 psi  
140 = 2000 psi  
200 = 3000 psi  
210 = 3000 psi  
250 = 3600 psi  
330 = 4700 psi  
400 = 5800 psi  
450 = 6500 psi  
500 = 7200 psi  
750 = 10000 psi

#### Fluid Port Connection

AK = BSP connection  
AB = Male / Female combination connection  
CK = Standard SAE connection  
(other fluid ports available upon request — consult factory)

#### Gas Precharge Pressure (P<sub>g</sub>) in bar (always required for E2 model gas valve)

xxx = 3 digits

# DIAPHRAGM ACCUMULATORS

## Dimensions

### Non-Repairable Welded Diaphragm Accumulators

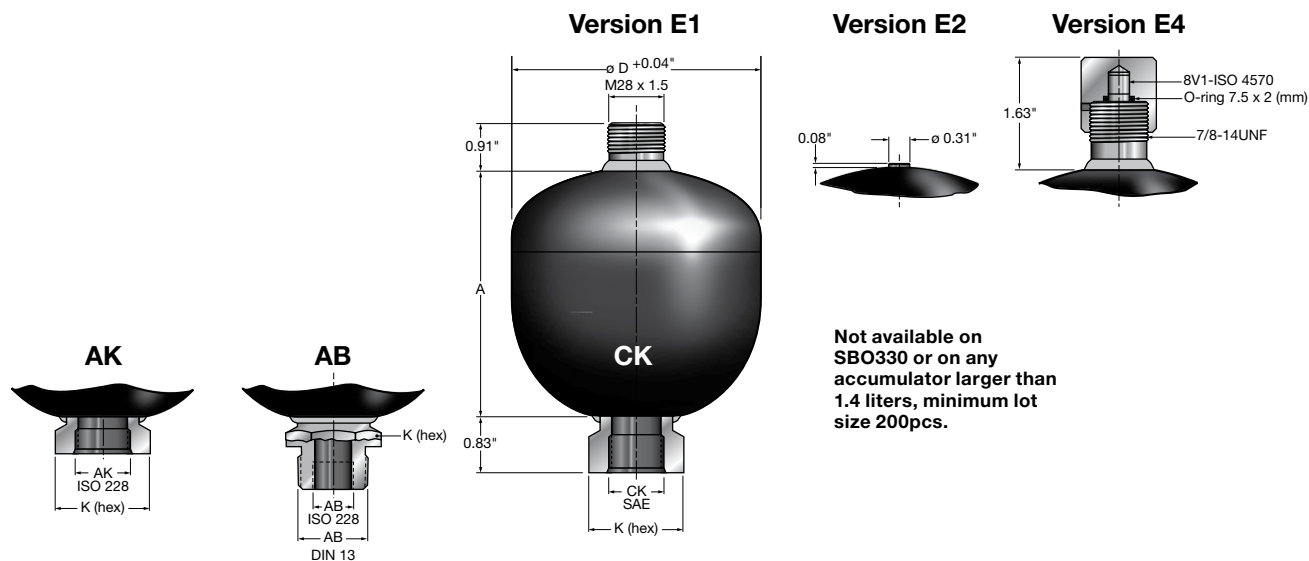

Not available on SBO330 or on any accumulator larger than 1.4 liters, minimum lot size 200pcs.

Series	Max. p2:p0	Size (L)	Eff. Gas Vol (in3)	MAWP psi/(bar)	Wt. lbs/(kg)	A in (mm)	$\phi D^{**}$ in (mm)	Thread-F				AK & CK K-Hex in (mm)	AB K-Hex in (mm)	Q gpm
								CK (SAE - female)	AK (BSPP - female)	AB (BSPP - female)	AB (DIN 13 - male)			
SBO 250	8:1	0.075	5	3600 (250)	1.5 (0.7)	2.68 (68.0)	2.52 (64.0)	9/16-18 UNF	G 1/2	N/A	N/A	1.18 (30)	N/A	10
SBO 210	8:1	0.16	10	2600/(180)*	1.8 (0.8)	3.15 (80.0)	2.91 (74.0)	9/16-18 UNF	G 1/2	N/A	N/A	1.18 (30)	N/A	10
				3000/(210)										
SBO 210	8:1	0.32	20	2400/(160)*	2.9 (1.3)	3.66 (93.0)	3.66 (93.0)	3/4-16 UNF	G 1/2	N/A	N/A	1.42 (36)	N/A	25
				3000/(210)										
SBO 210	8:1	0.5	30	3000 (210)	3.7 (1.7)	4.33 (110.0)	4.13 (105.0)	3/4-16 UNF	G 1/2	N/A	N/A	1.42 (36)	N/A	25
SBO 330	8:1	0.6	36	4700 (330)	7.3 (3.3)	5.04 (128.0)	4.53 (115.0)	3/4-16 UNF	G 1/2	G 1/2	M33 x 1.5	1.42 (36)	1.61 (41)	25
SBO 210	8:1	0.75	45	2000/(140)*	6.2 (2.8)	4.88 (124.0)	4.76 (121.0)	3/4-16 UNF	G 1/2	G 1/2	M33 x 1.5	1.42 (36)	1.61 (41)	25
				3000/(210)										
SBO 330	8:1	0.75	45	4700 (330)	8.9 (4.0)	4.78 (122.0)	4.96 (126.0)	3/4-16 UNF	G 1/2	G 1/2	M33 x 1.5	1.42 (36)	1.61 (41)	25
SBO 200	8:1	1	60	3000 (210)	7.9 (3.6)	5.39 (137.0)	5.35 (136.0)	3/4-16 UNF	G 1/2	G 1/2	M33 x 1.5	1.42 (36)	1.61 (41)	25
SBO 140	8:1	1.4	85	2000 (140)	8.6 (3.9)	5.91 (150.0)	5.71 (145.0)	3/4-16 UNF	G 1/2	G 1/2	M33 x 1.5	1.42 (36)	1.61 (41)	25
SBO 210	8:1	1.4	85	3000 (210)	11.9 (5.4)	6.14 (156.0)	5.91 (150.0)	3/4-16 UNF	G 1/2	G 1/2	M33 x 1.5	1.42 (36)	1.61 (41)	25
SBO 330	8:1	1.4	85	4700 (330)	16.6 (7.5)	6.33 (160.0)	6.1 (155.0)	3/4-16 UNF	G 1/2	G 1/2	M33 x 1.5	1.42 (36)	1.61 (41)	25
SBO 100	8:1	2	120	1500/(100)*	8.8 (4.0)	6.57 (167.0)	6.3 (160.0)	1 1/16 -12 UNF	G 3/4	G 3/4	M45 x 1.5	1.81 (46)	1.81 (46)	40
				1500/(100)										
SBO 210	8:1	2	120	3000 (210)	14.6 (6.6)	6.81 (173.0)	6.57 (167.0)	1 1/16 -12 UNF	G 3/4	G 3/4	M45 x 1.5	1.81 (46)	1.81 (46)	40
SBO 330	8:1	2	120	4700 (330)	17.7 (8.0)	7.12 (180.0)	6.77 (172.0)	1 1/16 -12 UNF	G 3/4	G 3/4	M45 x 1.5	1.81 (46)	1.81 (46)	40
SBO 210	4:1	2.8	170	3000 (210)	18 (8.2)	8.94 (227.0)	6.57 (167.0)	1 1/16 -12 UNF	G 3/4	G 3/4	M45 x 1.5	1.81 (46)	1.81 (46)	40
SBO 250	4:1	3.5	230	3000 (210)	24.6 (11.2)	11.14 (283.0)	6.69 (170.0)	1 1/16 -12 UNF	G 3/4	G 3/4	M45 x 1.5	1.81 (46)	1.81 (46)	40
SBO 330	4:1	3.5	230	4700 (330)	30.6 (13.8)	10.78 (274.0)	6.77 (172.0)	1 1/16 -12 UNF	G 3/4	G 3/4	M45 x 1.5	1.81 (46)	1.81 (46)	40

Dimensions are for general information only, all critical dimensions should be verified. Dimensions are in inches/(mm) and lbs/(kg)

\*Reduced MAWP values for stainless steel models

\*\*Diameter at electron beam weld at shell seam may be up to +0.150" larger in diameter

Model Codes containing RED selections are non-standard items – Contact HYDAC for information and availability. Not all combinations are available.

## Repairable Threaded Diaphragm Accumulators

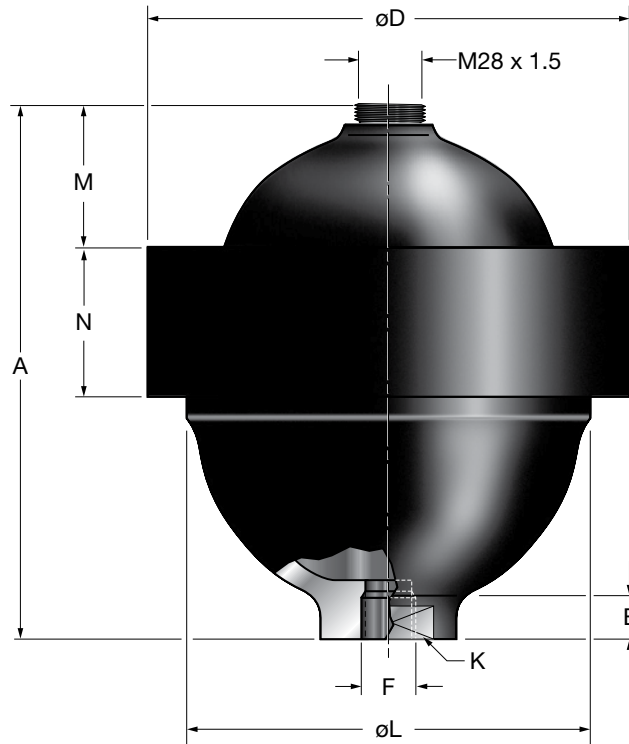

Series	Max. p2:p0	Size	Eff Gas Vol (in <sup>3</sup> )	MAWP psi (bar)	Weight lbs (kg)	A in (mm)	B in (mm)	Ø D in (mm)	Thread F		K - Hex in (mm)	Ø L in (mm)	M in (mm)	N in (mm)	Q gpm
									CK (SAE-female)	AK (BSPP-female)					
SBO 500	10:1	0.1	6	7200 (500)	4.2 (1.9)	4.33 (110)	1.18 (30)	3.74 (95)	3/4 - 16 UNF	G 1/2	1.26 (68)	2.68 (68)	0.87 (22)	1.38 (35)	25
SBO 500	10:1	0.25	15	5000/(350)*	8.6 (3.9)	5.04 (128)	0.79 (20)	4.53 (115)	3/4 - 16 UNF	G 1/2	1.42 (36)	3.62 (92)	0.71 (18)	2.17 (55)	25
				7200/(500)											
SBO 750	10:1	0.25	15	8700/(600)*	19.8 (9.0)	5.35 (136)	0.43 (11)	6.02 (153)	3/4 - 16 UNF	G 1/2	1.42 (36)	4.49 (114)	0.59 (15)	2.48 (63)	25
				10,000/(750)											
SBO 450	10:1	0.6	36	3600/(250)*	12.6 (5.7)	6.69 (170)	0.75 (19)	5.51 (140)	3/4 - 16 UNF	G 1/2	1.61 (41)	4.53 (115)	1.77 (45)	2.24 (57)	25
				4700/(330)											
SBO 210	10:1	1.3	80	3000 (210)	18.7 (8.5)	7.48 (190)	0.31 (8)	6.69 (170)	3/4 - 16 UNF	G 1/2	1.26 (32)	5.71 (145)	2.24 (57)	2.17 (55)	25
SBO 400	10:1	1.3	80	5800 (400)	24.7 (11.2)	7.75 (197)	1.1 (28)	7.91 (201)	3/4 - 16 UNF	G 3/4	1.97 (50)	6.3 (160)	1.97 (50)	2.56 (65)	25
SBO 250	10:1	2.0	120	2600/(180)*	25.1 (11.4)	8.93 (227)	0.67 (17)	7.91 (201)	1 1/16-12 UNF	G 3/4	1.61 (41)	6.61 (168)	2.44 (62)	2.52 (64)	40
				3600/(250)											

Dimensions are for general information only, all critical dimensions should be verified.

Dimensions are in inches/(mm) and lbs/(kg)

\*Reduced MAWP values for stainless steel models

# DIAPHRAGM ACCUMULATORS

## Diaphragm Spare Parts

Part Number	Item	Part Number	Item
2075359	Vent Screw M8 (w/ NBR Seal Ring) Version 1	2067728	Metal Valve Protection Cap, Version 1
2100344	Vent Screw M8 only	632865	Gas valve core (Version 4)
3878792	NBR Seal Ring, U9.3X13.3X1	237977	Valve seal cap (Version 4)
2127517	Plastic Valve Protection Cap, Version 1	626488	O-ring 7.5x2 (Buna)

## Water Service Accumulators

Size (liters)	Effective Gas Vol (in <sup>3</sup> )	MAWP psi (bar)	Model Code	Part Number	Fluid Connection Thread Size
---------------	--------------------------------------	----------------	------------	-------------	------------------------------

### Stainless Steel Port / Stainless Steel Shell

0.16	10	2600 (180)	SBO210-0.16E1/342S-180CA	3344456	SAE 3/4-16UNF-2A male
0.16	10	2600 (180)	SBO210-0.16E1/342S-180HA	2104224	1/2" NPTF male
0.16	10	2600 (180)	SBO210-0.16E1/346S-180HA	2108258	1/2" NPTF male
0.16	10	2600 (180)	SBO210-0.16E1/346U-180AK	3041996	G 1/2" BSPP female
0.25	15	5000 (345)	SBO500-0.25A6/342S-350AK	2110031	G 1/2" BSPP female
0.25	15	5000 (345)	SBO500-0.25A6/346S-350AK	2122000	G 1/2" BSPP female
0.25	15	10,800 (745)	SBO750-0.25A6/342S-750AK	2103443	G 1/2" BSPP female
0.25	15	10,800 (745)	SBO750-0.25A6/342S-750CK	2110811	SAE 3/4" -16 UNF female
0.25	15	10,800 (745)	SBO750-0.25A6/342U-750AK	3042064	G 1/2" BSPP female
0.32	20	2300 (160)	SBO210-0.32E1/342S-160HF	2111137	3/4" NPTF male
0.32	20	2300 (160)	SBO210-0.32E1/346S-160HF	2111138	3/4" NPTF male
0.6	36	3600 (250)	SBO450-0.6A6/342S-250AK	2121077	G 1/2" BSPP female
0.6	36	3600 (250)	SBO450-0.6A6/346U-250AK	3042074	G 1/2" BSPP female
0.75	45	2000 (140)	SBO210-0.75E1/342S-140HD	2108260	1" NPTF male
0.75	45	2000 (140)	SBO210-0.75E1/343S-140HD	2108850	1" NPTF male
0.75	45	2000 (140)	SBO210-0.75E1/346S-140HD	2106833	1" NPTF male
2.0	120	1450 (100)	SBO100-2E1/342S-100HC	2106047	1 1/4" NPTF male
2.0	120	1450 (100)	SBO100-2E1/342U-100AK	2105229	G 3/4" BSPP female
2.0	120	1450 (100)	SBO100-2E1/346S-100HC	2108262	1 1/4" NPTF male
2.0	120	2600 (180)	SBO250-2A6/342S-180AK	2103395	G 3/4" BSPP female
4.0	260	725 (50)	SBO50-4E1/342U-50AB	3107029	G 3/4" BSPP / M45 x 1.5
4.0	260	725 (50)	SBO50-4E1/346U1-50AB	3108261	G 3/4" BSPP / M45 x 1.5
4.0	260	2600 / 180	SBO250-4E1/344U-180CK	3586865	SAE 1 1/16" - 12 UNF female

### Plated Port / Plated Shell

0.16	10	3000 (210)	SBO210-0.16E2/422S-210HB031	2067722	1/2" NPTF male
0.16	10	3000 (210)	SBO210-0.16E2/422S-210HB034	2100033	1/2" NPTF male
0.16	10	3000 (210)	SBO210-0.16E2/422S-210HB086	2106845	1/2" NPTF male
0.75	45	5000 (340)	SBO330-0.75E1/422S-345AK	2120586	G 1/2" BSPP female

### Stainless Steel Port / Synthetic Coated Shell

0.6	36	4700 (320)	SBO330-0.6E1/302U-330AB	2111755	G 1/2" BSPP / M45 x 1.5
0.75	45	3000 (210)	SBO210-0.75E1/302S-210HD*	2114229	1" NPTF male
0.75	45	3000 (210)	SBO210-0.75E1/302S-210HD048	2084342	1" NPTF male
3.5	230	3000 (210)	SBO250-3.5E4/302S-210HC	2101745	1-1/4" NPTF male

### Fluid Port / Shell Material Combinations Which Are Not Available

32x	Stainless Steel Port	Chemically Plated Shell
40x	Chemically Plated Port	Synthetic Coated Shell
44x	Synthetic Coated Port	Chemically Plated Shell

RED selections are non-standard items – Contact HYDAC for information and availability. Not all combinations are available.