

D Piston Accumulators

A piston accumulator consists of a fluid section and a gas section with the piston acting as a gas-proof screen. The gas section is precharged with dry nitrogen gas. Auxiliary gas bottles are frequently used with piston accumulators to provide the required gas volume.

PISTON ACCUMULATORS

SK Series

Piston Accumulators



Description

Piston Accumulators are a cost effective option for numerous functions involving energy storage, and sometimes shock absorption in a hydraulic or fluid system. They are well suited for applications needing:

- High Pressure Ratios
- Large Volumes of Oil
- High Fluid flow rates
- Volume monitoring by way of piston position sensor or switch systems

Construction

HYDAC piston accumulators consist of:

- A cylinder with a finely finished internal surface
- An end cap on the gas side and fluid side, sealed with o-rings
- A lightweight metal piston
- A variety of sealing systems are available depending on the application

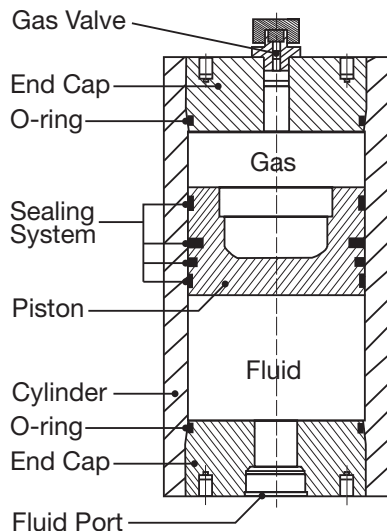

Piston Types

TYPE 2

Without Check Valves

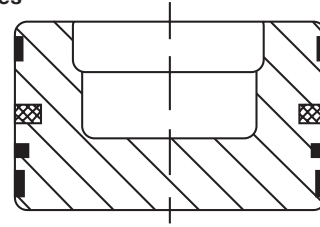

Application (without Check Valve)

Low-friction design for higher piston speeds, slow movements without stick-slip effect and high number of actuations (millions). Actual cycles achieved will vary with operating parameters.

Notes: Filtration $\leq 10 \mu\text{m}$ absolute. (ISO 17/15/12)
Max. continuous velocity = 12 ft/sec

TYPE 2

With Check Valves

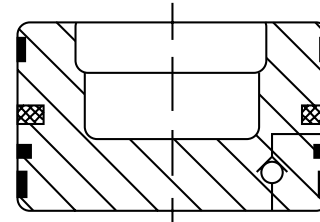

Application (with Check Valve)

The addition of a check valve drastically reduces the oil pumping to the gas side of the piston.

TYPE 3

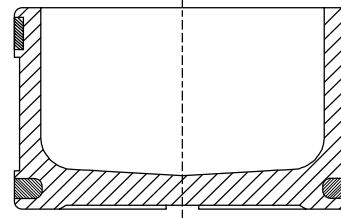

Application

Actual cycles achieved will vary with operating parameters.

Notes: Filtration $\leq 10 \mu\text{m}$ absolute. (ISO 17/15/12)

Max. continuous velocity = 3 ft/sec

Sealing Systems

Precise information about the proposed operating conditions is required in order to select the most appropriate sealing system. Important criteria for this selection are:

- Number of actuations or cycles
- Piston speed
- Temperature fluctuation
- Operating fluid
- Cleanliness of fluid
- Maintenance requirements

Seal Materials

The following sealing elastomers are available, depending on the operating conditions:

- NBR (acrylic nitrile butadiene rubber)
- FPM (fluoroelastomer)
- PUR (polyurethane)

Suitable materials are also available for low temperature applications.

Fluids

The following sealing materials are suitable for the fluids listed below:

NBR, resistant to:

- Mineral Oils (HL and HLP)
- Non-flammable fluids from groups HFA, HFB, and HFC
- Water and seawater up to approximately 100°C

NBR, not resistant to

- Aromatic hydrocarbons
- Chlorinated hydrocarbons
- Amines and ketones
- Hydraulic fluids from the HFD Groups

FPM, resistant to:

- Mineral Oils (HL and HLP)
- Hydraulic fluids from the HFD Groups
- Fuels as well as aromatic and chlorinated hydrocarbons
- Inorganic acids (but not all, please contact HYDAC)

FPM not resistant to:

- Ketones and amines
- (Anhydrous) ammonia
- Organic acids such as formic acid and acetic acid

PUR resistant to:

- Mineral Oils (HL and HLP)
- Non-flammable fluids from the HFA group

PUR not resistant to:

- Water and water-glycol mixtures
- Alkalis
- Acids

Corrosion Protection

For use with certain aggressive or corrosive fluids, or in a corrosive environment, HYDAC offers protective coatings and corrosive resistant materials (i.e. stainless steel) for the accumulator parts that come in contact with the fluid, or are exposed to the hostile environment.

System Mounting

HYDAC piston accumulators may operate in any position. Vertical installation is preferable with the gas side up. We recommend the use of our mounting components, which are detailed on page H21, to minimize risk of failure due to system vibrations.

Effects of Seal Friction

The permissible piston velocity depends on the sealing friction. Higher piston velocities are possible where there is less sealing friction.

HYDAC piston accumulators with low friction piston seals allow continuous operating velocities of up to 12 ft/sec with short bursts, up to 15 ft/sec (see type 2 piston).

Small pressure differentials between gas and oil side improve the effectiveness of HYDAC piston accumulators. To emphasize the friction effect on the pressure curve during an accumulation cycle, measurements with various sealing systems are illustrated.

The measurement graphs below are a true representation of the gas and oil pressure of piston accumulators with different sealing systems. The comparison of these two measurements clearly shows the difference in the pressure differential between gas and oil side:

Graph 1: Δp max. \approx 125 psi

Graph 2: Δp max. \approx 14.5 psi

The effect of the sealing friction on the working pressure is particularly striking in traditional piston designs. Abrupt piston movements (*the stick-slip effect*) are caused by the seal friction as shown in Graph 1. The low sealing friction of HYDAC type 2 pistons drastically reduces the stick-slip effect therefore maximizing piston responsiveness.

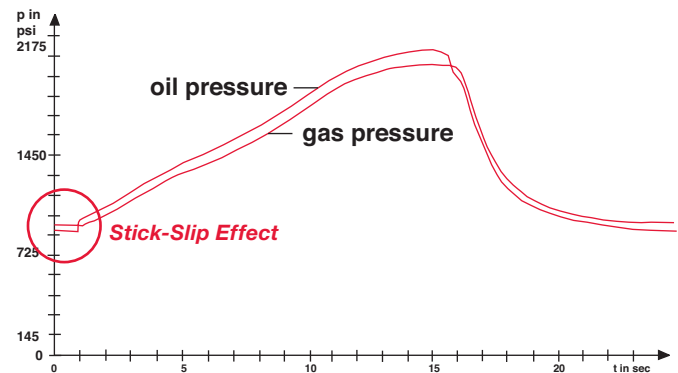

Graph 1: Traditional piston designs

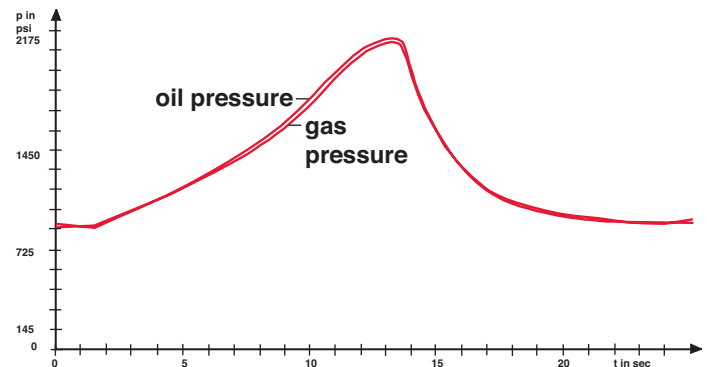

Graph 2: Piston Type 2 and Type 3 (low friction model)

Advantages of Using the Low-friction Sealing System (type 2):

- Minimum friction.
- Suitable for low pressure differentials.
- No start-up friction, no stick-slip.
- Low noise, no vibration.
- High piston speeds up to 12 ft/sec continuous.
- Improved accumulator efficiency.
- High life expectancy, low maintenance requirements.

Advantages of HYDAC Piston Accumulators

- Complete size range from 1 qt. to 100 gallons nominal volume.
- High ratios possible between precharge pressure and maximum working pressure.
- High flow rates - up to 4700 gpm from one accumulator.
- Power savings.
- Gas-proof and leak-free.
- No sudden discharge of gas when seal is worn.
- Space efficient.
- Piston location monitoring available.

SK 210 Series (Non-ASME) 3000 psi

Advantages

The piston accumulator series SK210 is an intermediate bore diameter with repairable design. They are HYDAC certified, designed in accordance with ASME pressure code. Features of this series are:

- Bore Diameter up to 6" ID
- Sizes from 1 quart to 15 gallons
- Largest range of standard models for quick delivery times
- Military Style Gas Valve, repairable

Application

- Mobile Hydraulic
- Industrial Hydraulic

SK 280 Series (Non-ASME) 4000 psi

Advantages

The piston accumulator series SK280 is a weight optimized, non-repairable design. The non-repairable design and special production process of these HYDAC accumulators save cost, making this series an economic option.

- Cost-effective – due to the non-repairable design and an optimized production process
- Weight reduced series
- Reduced installation space
- Standard-gas valve (HYDAC Version 1) with integrated M28x1.5 male thread
- Quick delivery for models with standard connection
- SAE fluid ports are available
- PED/CE pressure code certification

Application

- Mobile Hydraulic
- Weight Sensitive Industrial Hydraulic

SK 350 Series (Non-ASME) 5000 psi

Advantages

The piston accumulator series SK350 are an intermediate bore diameter with repairable design. They are HYDAC certified, designed in accordance with ASME pressure code. Features of this series are:

- Bore Diameter up to 6" ID
- Sizes from 1 quart to 15 gallons
- Largest range of standard models for quick delivery times
- Military Style Gas Valve, repairable

Application

- Mobile Hydraulic
- Industrial Hydraulic

SK 350 & 600 Series (ASME) 3000 psi & 5000 psi

Advantages

The piston accumulator series SK350 & 600 are HYDAC's most versatile series with a repairable design and large selection of options. The largest range of possible sizes, material construction, and other options are offered. Standard and Low Friction piston designs are available for superior performance and flow rates. Features of this series are:

- Bore Diameters from 2.4" ID to 19.3" ID
- Sizes from 1 quart to 200 gallons
- Largest range of possible sizes and material options
- Standard and Low Friction piston designs available
- Largest variety of gas and fluid port options
- A variety of piston position sensor monitoring systems are available
- ASME, CRN, PED/CE and other pressure code certifications are available

Application

- Heavy Mobile Hydraulic
- Industrial Hydraulic

Piston Position Indicators

Examples of piston monitoring devices.

Further options for determining the piston position and detailed technical data available on request.

Electrical limit switch

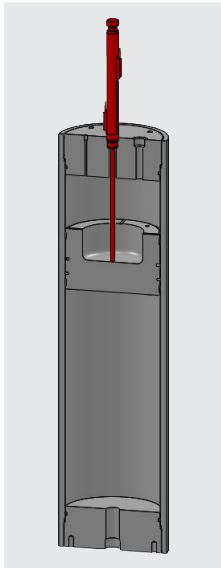

What is measured?

Max. or set fill level of the piston accumulator

How are measurements taken?

As point measurements

Where to measure?

Gas side

Identification in the model code:

A, B, C, ..., depending on stroke

Product information:

No. 10000769094

Piston position switch

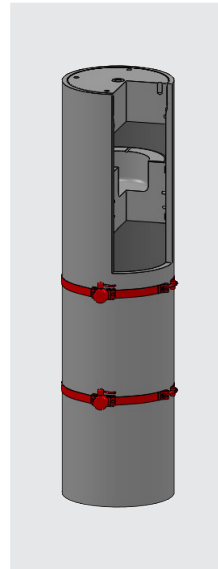

What is measured?

Piston position via ultrasonic measurement

How are measurements taken?

As point measurements

Where to measure?

Fluid side

Identification in the model code:

UP...

Product information:

No. 10000769179

Magnetic flap indication

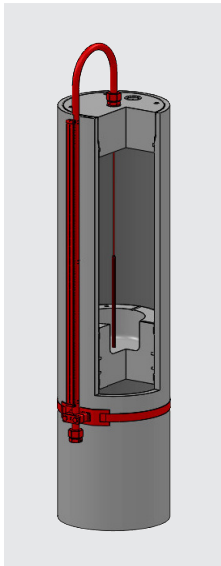

What is measured?

Piston position via a magnet fastened to the cable that moves coloured flaps that can be read from the outside

How are measurements taken?

Continuously

Where to measure?

Gas side

Identification in the model code:

M

Product information:

No. 10000769200

Linear position measurement system

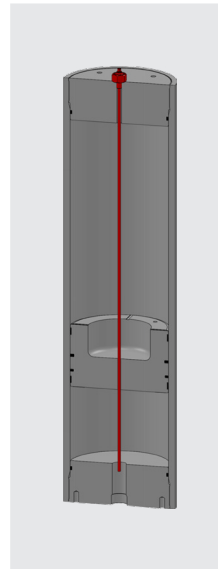

What is measured?

Piston position via elapsed time measurement

How are measurements taken?

Continuously

Where to measure?

Gas side

Identification in the model code:

L

Product information:

No. 10000810655

Cable tension measurement system

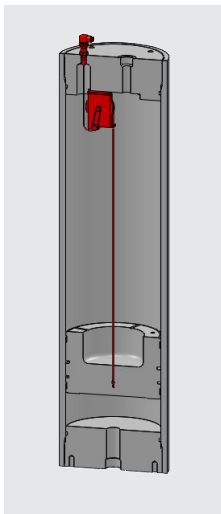

What is measured?

Piston position via a cable fastened to the piston

How are measurements taken?

Continuously

Where to measure?

Gas side

Identification in the model code:

S

Product information:

No. 10000641374

Laser linear position measurement system

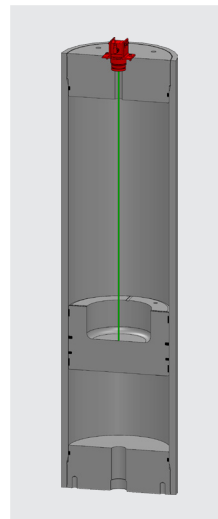

What is measured?

Piston position via laser elapsed time measurement

How are measurements taken?

Continuously

Where to measure?

Gas side

Identification in the model code:

LA

Product information:

No. 10000810664

PISTON ACCUMULATORS

Model Code

SK 210 - 20 / 2112 S - 210 F C F - V E - 18 - H

Series

- SK 210 = Piston Accumulator (3000 psi, Typically) - Non-ASME
- SK 280 = Piston Accumulator (4000 psi, Typically) - Non-Repairable
- SK 350 = Piston Accumulator (3000 psi, Typically) - ASME
- SK 350 = Piston Accumulator (5000 psi, Typically) - Non-ASME
- SK 600 = Piston Accumulator (5000 psi, Typically) - ASME

Size (in Liters, see tables on dimension pages to follow)

- 20 = 20 Liters

...see tables on following pages for complete list of sizes, and which versions they are available in

Material and Piston Type

For series SK 280, only material combinations 3218, 3268 are available

Piston Type (see page D2)

- 2 = Low Friction Model
- 3 = General Duty

Piston Material

- 1 = Aluminum
- 2 = Carbon steel (machined)
- 3 = Stainless steel
- 4 = Carbon steel with internal surface protection (machined)
- 5 = Steel (cold impact formed)

Cylinder and End Cap Material

- 1 = Carbon steel (machined)
- 2 = Carbon steel with external surface protection (machined)
- 3 = Stainless steel
- 6 = Low temperature carbon steel (< -20°F)

Seal Material (including piston seals)

- 2 = NBR (-4 to 180°F)
- 5 = Low Temperature NBR (-50 to 180°F)
- 6 = FPM fluoroelastomer (5 to 320°F)
- 8 = PUR Polyurethane (-22 to 180°F)

Country of Installation

- S = USA
 - S1 = Canada (CRN registered)
 - U = PED/CE
- (for other countries see page 3 for proper code designation)

Maximum Working Pressure in bar (based upon first choice - SERIES)

- 210 = 3000 psi
- 280 = 4000 psi (SK 280 typically)
- 345 = 5000 psi

Fluid Port Connection

Type of Connection (refer to tables on the following page)

- A = Threaded, Female
- F = Flanged

Standard / Specification of Type of Connection (refer to tables on the following page)

- A, B, C, D

Size of Connection (refer to tables on the following page)

- A, B, C, D, E, ...

Gas Side Connection

Type of Connection (refer to tables on the following page)

- A = Threaded, Female
- F = Flanged
- V = Gas Valve
- KCH = 2 PC Gas Valve (with protective cover) Requires an FPO Charging Kit
- 000 = Factory Precharged and sealed (not rechargeable) for SK280 series only. Required min order qty. 200

Standard/Specification of Type of Connection (OMIT if V was selected from Type of Connection, refer to tables on the following page)

- (omit), A, B, C, D

Size of Connection (refer to tables on the following page)

- A, B, C, D, E, ...

Piston Diameter (Some piston diameters are only available in certain series)

- | | | |
|------------|------------|------------|
| 05 = 50mm | 12 = 125mm | 25 = 250mm |
| 06 = 60mm | 15 = 150mm | 35 = 355mm |
| 08 = 80mm | 18 = 180mm | 49 = 490mm |
| 10 = 100mm | | |

Supplementary Equipment (only available for series SK350 & SK600)

- | | |
|---|---|
| A = Electrical Limit Switch (35mm stroke) | LA = Laser linear position measurement system |
| B = Electrical Limit Switch (200mm stroke) | M = Magnetic flapper indication |
| C = Electrical Limit Switch (500mm stroke) | S = Cable tension measurement system |
| E... = Special switch1 (fixed and adjustable) | U = Ultrasonic measurement system |
| K = Protruding Piston Rod | UP.. = Piston position switch (e.g. UP2=2 position switches, UPEX=ATEX version) |
| L = Linear position measurement system | W = limit switch with linear distance sensor |

Safety Devices

- 1 = Burst Disc (see page A10)
- 2 = Gas safety valve (see page A10)
- 3 = Thermal fuse cap (see page H2 and H3)

H = Made in the USA (not available for series SK280)

1) Consult HYDAC for assistance with specifying switch details

Model Codes containing RED selections are non-standard items – Contact HYDAC for information and availability. Not all combinations are available.

Connections Model Code Support Tables for Fluid Connections

Female Threaded Connections: A⁽¹⁾ Sample Code = A⁽¹⁾ A⁽²⁾ A⁽³⁾

Code	Type of Connection	Code, Size											
		A	B	C	D	E	F	G	H	J	K	L	M
A	BSPP (ISO 228)	G1/8	G1/4	G3/8	G1/2	G3/4	G1	G1 1/4	G1 1/2	G2	G2 1/2	G3	N/A
B	DIN 13 or ISO 965/1 (Metric)	M10x1	M12x1.5	M14x1.5	M16x1.5	M18x1.5	M22x1.5	M27x2	M33x2	M42x2	M48x2	M60x2	N/A
C	ANSI B1.1 (UN...2B) Seal SAE J 514	SAE-2 5/16- 24UNF	SAE-3 3/8- 24UNF	SAE-4 7/16- 20UNF	SAE-5 1/2- 20UNF	SAE-6 9/16- 18UNF	SAE-8 3/4- 16UNF	SAE-10 7/8- 14UNF	SAE-12 1 1/16- 12UN	SAE-14 1 3/16- 12UN	SAE-16 1 5/16- 12UN	SAE-20 1 5/8 12UN	SAE-24 1 7/8 12UN
D	ANSI B1.20.3	1/16-27	1/8-27	1/4-18	3/8-18	1/2-14	3/4-14	1-11 1/2	1 1/4-11 1/2	1 1/2-11 1/2	2-11 1/2	2 1/2-8	N/A

- 1) use "A" as the first character of the connection code for all Female Threaded Connections.
 2) Enter the letter of the ROW (red) as the second character of the connection code.
 3) Enter the letter of the COLUMN (gray) as the third character of the connection code.

Flange Connections: F⁽⁴⁾ Sample Code = F⁽⁴⁾ C⁽⁵⁾ B⁽⁶⁾

Code	Type of Connection	A	B	C	D	E	F	G	H	J	K	L	M
A	DIN Standards	DN15	DN25	DN40	DN50	DN65	DN80	DN100	DN125	DN150	DN200	N/A	N/A
B	ANSI B 16.5	1/2"- 1500 PSI	1"-1500 PSI	1 1/2"- 1500 PSI	2"-1500 PSI	2 1/2"- 1500 PSI	3"-1500 PSI	1/2"- 2500 PSI	1"-2500 PSI	1 1/2"- 2500 PSI	2"-2500 PSI	2 1/2"- 2500 PSI	N/A
C	SAE Code 61 (3000 psi)	1/2"	3/4"	1"	1 1/4"	1 1/2"	2"	2 1/2"	3"	3 1/2"	4"	5"	N/A
D	SAE Code 62 (6000 psi)	1/2"	3/4"	1"	1 1/4"	1 1/2"	2"	2 1/2"	3"	N/A	N/A	N/A	N/A
E	High Pressure Bosch PN320	DN32	DN40	DN50	DN65	DN80	DN100	DN125	DN150	N/A	DN25	N/A	N/A
F	High Pressure AVIT, HAVIT	DN32	DN40	DN50	DN65	DN80	DN100	DN125	DN150	N/A	DN25	N/A	N/A

- 4) Use "F" as the first character of the connection code for all Flange Connections.
 5) Use "C" as the second character of the connection code for all flange connections.
 6) Enter the letter of the COLUMN (gray) as the third character of the connection code.

Gas Valve Connections: V or K⁽⁷⁾ Sample Code = V⁽⁷⁾ (omit)⁽⁸⁾ A

Code	Type of Connection
VA	G 3/4 male with M28x1.5/M8 (standard HYDAC gas valve version 1)
VB	M28 x 1.5 / M8 Integrated in gas side end-cap
VC	1/2"-20UNF male with M16x2 (ISO 10945)
VD	M14x1.5 male with male M16x1.5 (Minimess)
VE	G 3/4 male with 7/8-14 UNF-VG8 (standard HYDAC gas valve version 4)
VF	M42x1.5/M12 in end cap
KCH	2 Piece gas valve

- 7) use "V" as the first character of the connection code for all Gas Valve Connections.
 8) OMIT the second character of the connection code.

Other Connections & Custom Solutions are Available:

HYDAC has the capabilities to produce accumulators with many other types of connections. The options listed above are simply the most common, and most readily available. Other connection options include:

- Male threads
- Protruding flanges
- Autoclave

Custom solutions that incorporate valve/manifold assemblies are also available, for more information on special connections and custom solutions, consult factory.

PISTON ACCUMULATORS

Dimensions

SK 210 Series (Non-ASME) 3000 psi

SK 350 Series (Non-ASME) 5000 psi

Series	Nominal Size gal.	Effective Gas Volume in ³ /L	Weight lbs / (kg)	A in / (mm)	ø D1 in / (mm)	ø D2 in / (mm)
SK 210	0.25	77.5 / 1.27	38 / 17	18 / 457	4 / 100	4.92 / 125
	0.5	138 / 2.27	50 / 23	22 / 569		
	1	260 / 4.27	71 / 32	31 / 791		
	2	504 / 8.27	107 / 49	45 / 1131		
	1	294 / 4.82	94.7 / 43	17.1 / 435	6 / 150	6.89 / 175
	1.5	416 / 6.82	107.4 / 48.8	21.7 / 550		
	2.5	660 / 10.82	132 / 60.1	30.5 / 775		
	5	1270 / 20.82	1945 / 88.4	52.8 / 1340		
	7.5	1759 / 28.82	245.2 / 111.4	70.9 / 1800		
10	2491 / 40.82	319.6 / 145.3	97.4 / 2475			

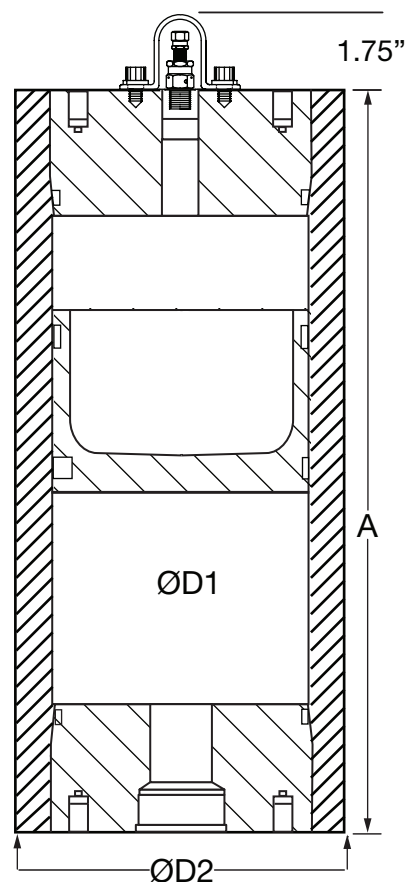

Series	Nominal Size gal.	Effective Gas Volume in ³ /L	Weight lbs / (kg)	A in / (mm)	ø D1 in / (mm)	ø D2 in / (mm)
SK 350	0.2	0.05	15 / (7)	8.6 / (218)	2.36 (60)	3.15 (80)
	0.5	0.125	20 / (9)	12.8 / (325)		
	1	0.25	26 / (12)	19.8 / (502)		
	0.5	0.125	24 / (11)	9.8 / (250)	3.15 (80)	3.94 (100)
	1	0.25	29 / (13)	13.8 / (350)		
	2	0.5	40 / (18)	21.7 / (550)		
	2.5	0.625	62 / (28)	20.9 / (532)	3.94 (100)	4.96 (126)
	5	1.25	88 / (40)	33.5 / (850)		
	7.5	1.875	115 / (52)	46.1 / (1170)		
	2	0.5	82 / (37)	13.6 / (345)	4.92 (125)	6.30 (160)
	5	1.25	115 / (52)	23.2 / (590)		
	15	3.75	225 / (102)	55.3 / (1405)		
	6	1.5	128 / (58)	21.5 / (545)	5.91 (150)	7.09 (180)
	20	5	231 / (105)	52.6 / (1335)		
	40	10	386 / (175)	97.2 / (2470)		

Note: Other sizes available on request. Intermediate sizes are possible, depending on the length/diameter required. Please consult factory for details on special sizes.

Dimensions are for general information only, all critical dimensions should be verified.

Standard Product Offering

Nom. Size (gal.)	øD1 (in Nom.) / (mm)	Fluid Port	Model Code	Max Working Pressure (psi)
0.25	4 / (100)	SAE-20 (1 5/8-12 UN)	SK210-1/3218S-210-ACL-KCH-10H	3000
0.50	4 / (100)	SAE-20 (1 5/8-12 UN)	SK210-2/3218S-210-ACL-KCH-10H	3000
1	4 / (100)	SAE-20 (1 5/8-12 UN)	SK210-4/3218S-210-ACL-KCH-10H	3000
2	4 / (100)	SAE-20 (1 5/8-12 UN)	SK210-8/3218S-210-ACL-KCH-10H	3000
1	6 / (150)	SAE-24 (1 7/8-12 UN)	SK210-4/3218S-210ACM-KCH-15H	3000
1.5	6 / (150)	SAE-24 (1 7/8-12 UN)	SK210-6/3218S-210ACM-KCH-15H	3000
2.5	6 / (150)	SAE-24 (1 7/8-12 UN)	SK210-10/3218S-210ACM-KCH-15H	3000
5	6 / (150)	SAE-24 (1 7/8-12 UN)	SK210-20/3218S-210ACM-KCH-15H	3000
7.5	6 / (150)	SAE-24 (1 7/8-12 UN)	SK210-28/3218S-210ACM-KCH-15H	3000
10	6 / (150)	SAE-24 (1 7/8-12 UN)	SK210-40/3218S-210ACM-KCH-15H	3000

Standard Dimensions SK 280 Series (Non-ASME) 4000 psi (Non-repairable)

Nominal Volume (L)	A +/- 3 (mm)	Thread F		Weight (kg)	D1 (mm)	D2 (mm)
		BSPP female	SAE female			
0.16	160	G 1/2	9/16-18-2B	2	50	60
0.32	240	G 1/2	9/16-18-2B	2.5		
0.5	335	G 1/2	3/4-16-2B	3.1		
0.75	460	G 1/2	3/4-16-2B	4		
1	590	G 1/2	3/4-16-2B	4.8		
0.32	205	G 1/2	3/4-16-2B	4	60	75
0.5	265	G 1/2	3/4-16-2B	4.7		
0.75	355	G 1/2	3/4-16-2B	5.8		
1	445	G 1/2	3/4-16-2B	6.9		
1.5	620	G 1/2	3/4-16-2B	9.1		
2	800	G 1/2	3/4-16-2B	11.4		
2.5	975	G 1/2	3/4-16-2B	13.6	80	95
0.5	210	G 3/4	1 1/16-12-2B	6.5		
0.75	260	G 3/4	1 1/16-12-2B	7.2		
1	310	G 3/4	1 1/16-12-2B	8		
1.5	410	G 3/4	1 1/16-12-2B	9.5		
2	510	G 3/4	1 1/16-12-2B	11.5		
2.5	605	G 3/4	1 1/16-12-2B	13		
3	705	G 3/4	1 1/16-12-2B	14.5		
3.5	805	G 3/4	1 1/16-12-2B	16		
4	905	G 3/4	1 1/16-12-2B	17.5		
0.75	235	G 1	1 5/16-12-2B	11.7	100	125
1	265	G 1	1 5/16-12-2B	12.5		
1.5	330	G 1	1 5/16-12-2B	14.3		
2	395	G 1	1 5/16-12-2B	16		
2.5	460	G 1	1 5/16-12-2B	18		
3	520	G 1	1 5/16-12-2B	19.5		
3.5	585	G 1	1 5/16-12-2B	21.5		
4	650	G 1	1 5/16-12-2B	23		
5	775	G 1	1 5/16-12-2B	26.3	125	150
6	900	G 1	1 5/16-12-2B	30		
4	445	G 1	1 5/16-12-2B	29		
5	528	G 1	1 5/16-12-2B	32.5		
6	609	G 1	1 5/16-12-2B	36		
7	691	G 1	1 5/16-12-2B	39.5		
8	772	G 1	1 5/16-12-2B	43		
9	854	G 1	1 5/16-12-2B	46.5	150	175
10	935	G 1	1 5/16-12-2B	50		
6	467	G 1	1 5/16-12-2B	39.4		
8	581	G 1	1 5/16-12-2B	45.1		
10	695	G 1	1 5/16-12-2B	50.8		
12	809	G 1	1 5/16-12-2B	56.5		
14	980	G 1	1 5/16-12-2B	65.1		

Dimensions 000 Connection - Not Rechargeable

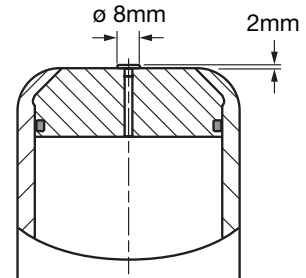

VB Connection - Refillable

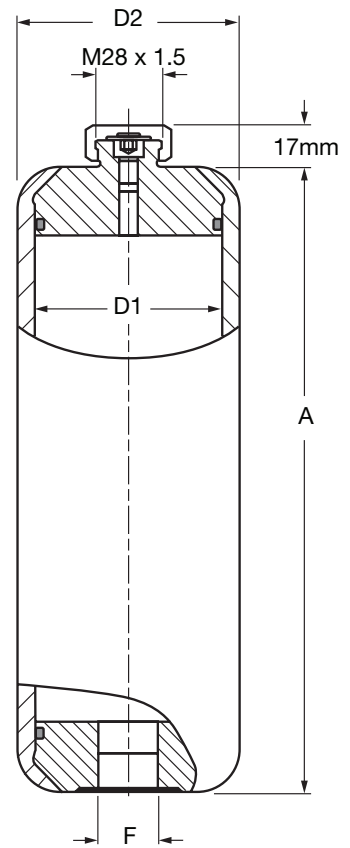

Clamps for D1=50mm D2=60mm Part Number 3018442
 Clamps for D1=60mm D2=75mm Part Number 444912
 Clamps for D1=80mm D2=95mm Part Number 444995
 Clamps for D1=100mm D2=120mm Part Number 444505
 Clamps for D1=125mm D2=150mm Part Number 444321
 Clamps for D1=150mm D2=175mm Part Number 444402
 see page H22 for details

Dimensions are for general information only, all critical dimensions should be verified.

PISTON ACCUMULATORS

Type 2 Dimensions

SK 350 Series (ASME) 3000 psi

Gas Valve Version 1 (code designation VA)
Uses Charging Unit FPK

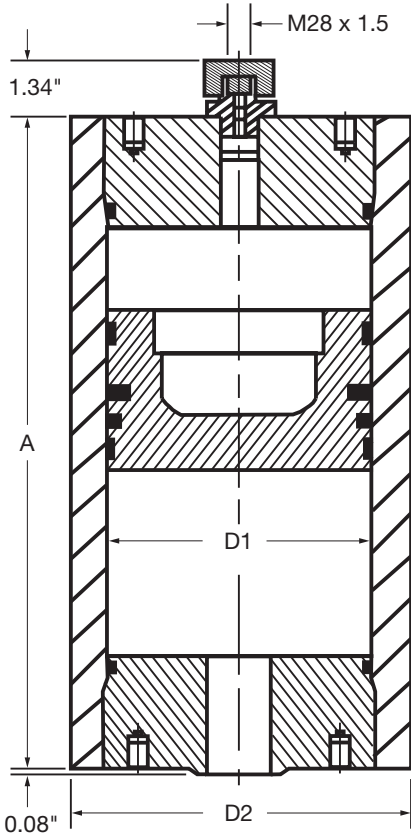

Flange Connection (code designation F_ _)
(specified by model code)

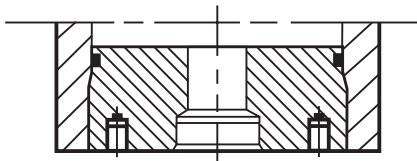

Threaded Connection (code designation A_ _)
(specified by model code)

Gas Valve Version 4 (code designation VE)
Uses Charging Unit FPS

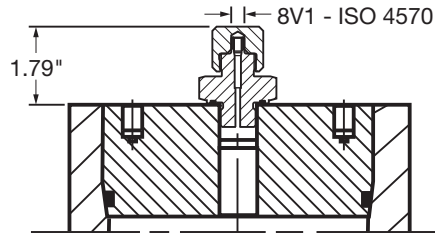

Gas Valve 2 PC (code designation KCH)
Uses Charging Unit FPO

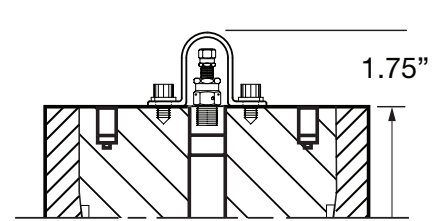

3000 psi maximum working pressure

Size liters	Effective Gas Volume gal	Weight lbs / (kg)	A in / (mm)	ø D1 in / (mm)	ø D2 in / (mm)
10	2.5	235 / (106)	28 / (710)	7.09 (180)	8.62 (219)
20	5	318 / (144)	43.4 / (1103)		
28	7.5	383 / (174)	55.8 / (1418)		
38	10	465 / (211)	71.3 / (1811)		
47	12.5	540 / (245)	85.2 / (2165)		
57	15	622 / (282)	100.7 / (2558)	9.84 (250)	12.21 (310)
40	10	788 / (357)	49 / (1245)		
50	12.5	882 / (400)	57.1 / (1450)		
60	15	974 / (442)	65 / (1651)		
75	20	1114 / (505)	77.1 / (1958)		
100	25	1347 / (611)	97.1 / (2466)		
115	30	1488 / (675)	109.2 / (2774)		
135	35	1676 / (760)	125.3 / (3183)	13.98 (355)	17.09 (434)
150	40	1816 / (824)	137.4 / (3490)		
170	45	2004 / (909)	152.4 / (3871)		
190	50	2194 / (994)	168.4 / (4277)		
100	25	1859 / (843)	61.9 / (1572)		
115	30	1986 / (901)	67.9 / (1725)		
150	40	2287 / (1037)	81.8 / (2078)		
190	50	2630 / (1193)	97.7 / (2482)	121.6 / (3089)	141.5 / (3594)
250	65	3144 / (1426)	121.6 / (3089)		
300	80	3572 / (1620)	141.5 / (3594)		

Clamps for D1=180mm Part Number 237401 see page H22

Clamps for D1=250mm Part Number 237389 see page H22

Clamps for D1=355mm (refer to factory)

Type 2 Dimensions SK 600 Series (ASME) 5000 psi

Gas Valve Version 1 (code designation VA)
Uses Charging Unit FPK

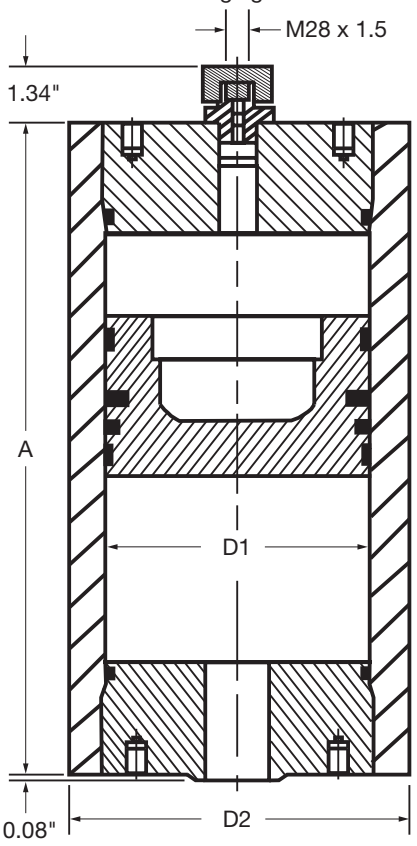

Flange Connection (code designation F__)
(specified by model code)

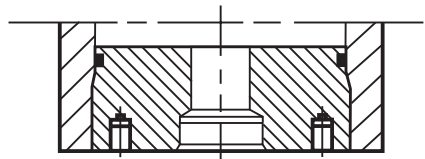

Threaded Connection (code designation A__)
(specified by model code)

Gas Valve Version 4 (code designation VE)
Uses Charging Unit FPS

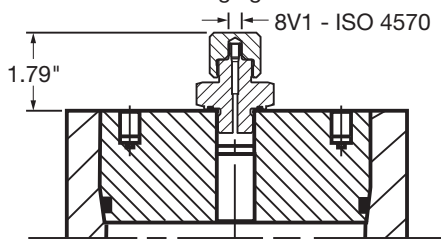

Gas Valve 2 PC (code designation KCH)
Uses Charging Unit FPO

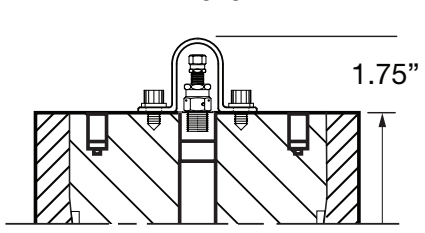

5000 psi maximum working pressure

Size liters	Effective Gas Vol gal	Weight lb (kg)	A in (mm)	ø D1 in / (mm)	ø D2 in / (mm)
10	2.5	302 / (137)	28 / (711)	7.09 (180)	9.61 (244)
16	4	402 / (182)	37.2 / (945)		
20	5	447 / (203)	43.4 / (1102)		
30	7.5	606 / (275)	58.9 / (1496)		
40	10	736 / (334)	74.4 / (1890)		
50	12.5	884 / (401)	89.9 / (2283)	9.84 (250)	13.31 (338)
40	10	1110 / (503)	49 / (1245)		
50	12.5	1254 / (569)	57.1 / (1450)		
60	15	1396 / (633)	65 / (1651)		
75	20	1611 / (731)	77.1 / (1958)		
100	25	1969 / (893)	97.1 / (2466)		
115	30	2184 / (990)	109.2 / (2774)		
135	35	2472 / (1121)	125.3 / (3183)		
150	40	2689 / (1220)	137.4 / (3490)		
170	45	2977 / (1350)	153.5 / (3899)		
190	50	3265 / (1481)	169.5 / (4305)		

Dimensions are for general information only, all critical dimensions should be verified. Consult factory for clamps on these accumulators.

PISTON ACCUMULATORS

Spare Parts

Seal Kits & Replacement Pistons

For seal kits other than Buna N, and for sizes not listed please consult factory.

Example: SK 350 - 20 / 2112 S - 210 FCF - VE - 18 E - 1 (see page D12 for details)

Piston Type

Diameter

Piston Seal Kits

Diameter	Type 2 (NBR)	Type 3 (PUR/NBR)
60	3090507	3016210
80	3041573	3013230
100	3671731	2123414
125	3116665	2128104
150	3355275	3145418
180	0363270	2123415
200	3110810	3113127
250	3671733	3016213
310	3016200	4374872
355	0363272	3726888
490	3104100	3894300

Replacement Pistons - with Seals

Diameter	Type 2 (NBR)	Type 3 (PUR/NBR)
60	3183495	3009372
80	3183496	2119931
100	3175476	2115547
125	3016232	3016150
150	3016228	3016231
180	2118451	3046277
200	-	-
250	0353980	3016171
310	3016195	-
355	0356382	4323005
490	3128989	4323006

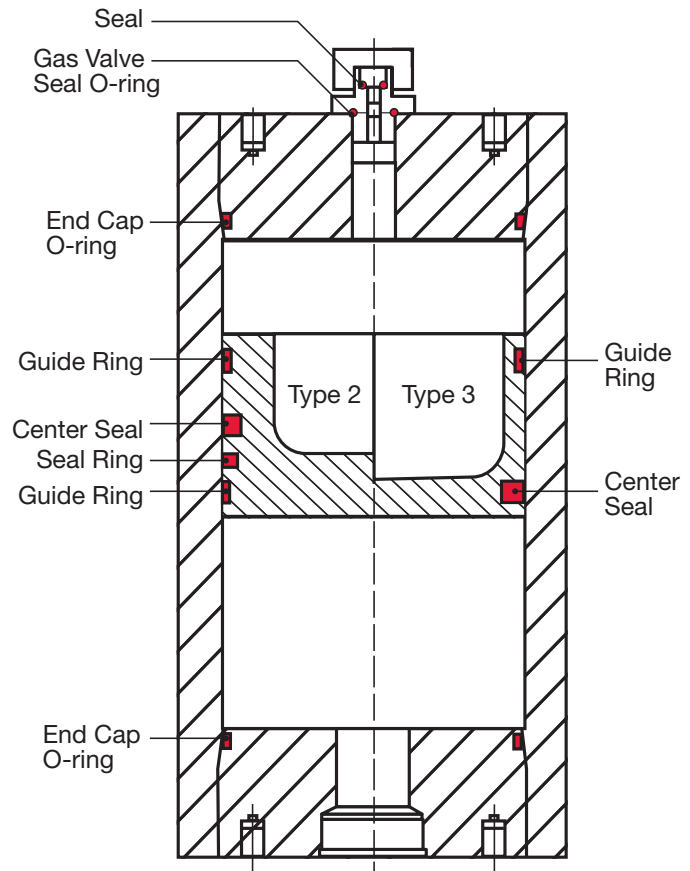

Tools

When repairing a piston accumulator, it is critical to use the appropriate tools to avoid seal damage.

There are two tools required:

Seal Assembly Tool: allows for gradual and even stretching of the seals when installing them onto the piston.

Piston Insertion Tool: a tapered shroud that protects the seals from the threaded portion of the shell, and provides even seal compression and piston alignment when inserting the piston into the shell.

Diameter	Seal Assembly	Piston Insertion
06 (60 mm)	297430	2120188
08 (80 mm)	244991	359614
10 (100 mm)	352198	2117672
12 (125mm)	370734	2128223
15 (150 mm)	2124157	3680195
18 (180 mm)	3713269	3028679
25 (250 mm)	3715658	3026807
31 (310 mm)	3721000	3027403
35 (355 mm)	3728790	3389677
49 (490mm)	3114220	3440695

For items not listed please contact HYDAC.

Parts containing RED apply to piston accumulators built in the USA. Different country of origin may require a different part. Consult HYDAC for assistance with specifying piston insertion tool.

WARNING: Only qualified persons should perform maintenance on any type of accumulator. Complete maintenance instructions are available - Contact HYDAC.

