

# SOLENOID VALVES

## WK08C-01

### Spool Type, Direct Acting

Up to 5 gpm (19 l/min) • 5000 psi (350 bar)

#### Hydraulic Symbol

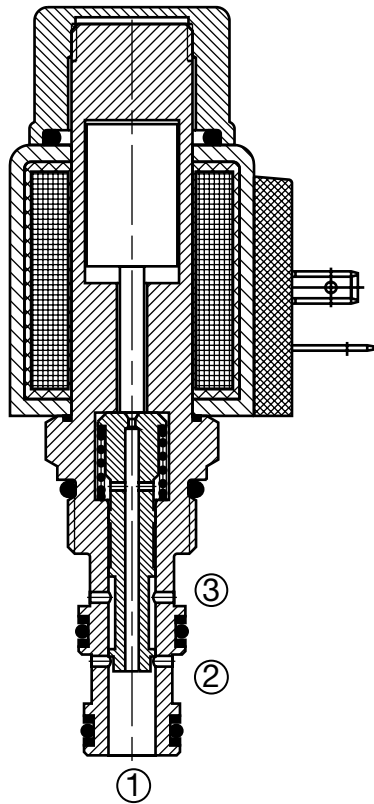
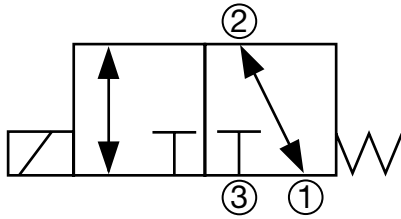

#### Description

A screw-in cartridge, solenoid operated, 3-way, 2 position, direct acting, spool type valve.

#### Operation

When de-energized the WK08C allows flow from port 2 to port 1 bi-directionally, while blocking flow at port 3. When energized the spool shifts and opens flow from port 2 to port 3 bi-directionally, while blocking flow at port 1.

**Operation of Manual Override Option:** To override, push and hold the override button. The override is not detented. The manual override option is intended for emergency use, not for continuous duty operation.

#### Features

- Push type manual override button, protected by rubber cap

#### Specifications

Operating Pressure	5000 psi (350 bar)
Nominal Flow	5 gpm (19 l/min)
Internal Leakage	5.5 cu in/min. at 3600 psi and 158 SUS (90 cc/min at 250 bar and 34 cSt)
Fluid Operating Temp. Range	-4° to 248°F (-20° to 120°C) <i>(Consult factory for usage at temp. outside range.)</i>
Ambient Temperature Range	-4° to 140°F (-20° to 60°C)
Coil Duty Rating	Continuous from 85% to 115% of nominal voltage
Current Draw @ 68°F (20°C)	1.5 A at 12VDC; 0.8 A at 24VDC
Min. Pull-in Voltage @ 68°F (20°C)	85% of nominal @ 5000 psi (350 bar)
Fluid Compatibility	Mineral-based or synthetics with lubricating properties
Viscosity	50 to 2000 SUS (7.4 to 420 cSt)
Filtration	21/19/16 or cleaner (per ISO 4406). Use with filter rated $\beta_{10} \geq 200$ .
Installation	No orientation restrictions
Cavity	FC08-3 (see <i>Line Bodies &amp; Cavities</i> section)
Cavity Tools	Rougher: 02580086 Finisher: 02580087
Cartridge Weight	0.40 Lbs. (0.18 kg)
Coil Weight	0.42 Lbs. (0.19 kg)
Cartridge Material	Steel with hardened work surfaces. Zinc-plated exposed surfaces. Buna N or Viton® o-rings. PTFE back-up rings.
Coil Material	Class N high temperature magnet wire, steel shell, polyamid encapsulation.
Seal Kits	Buna-N P/N: 03054795 Viton® P/N: 02591059

#### Performance

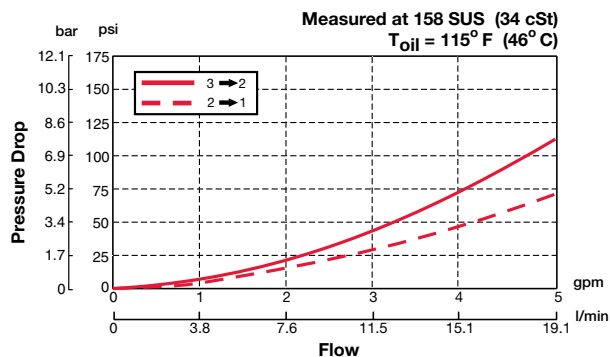

## Dimensions

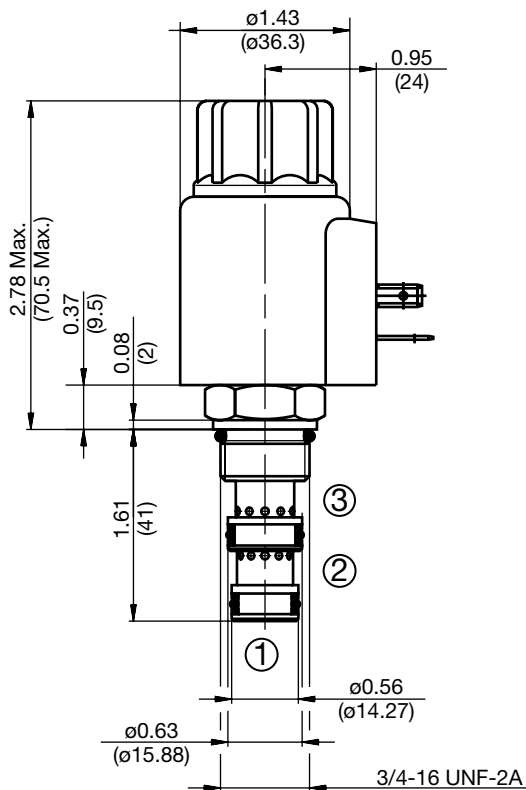
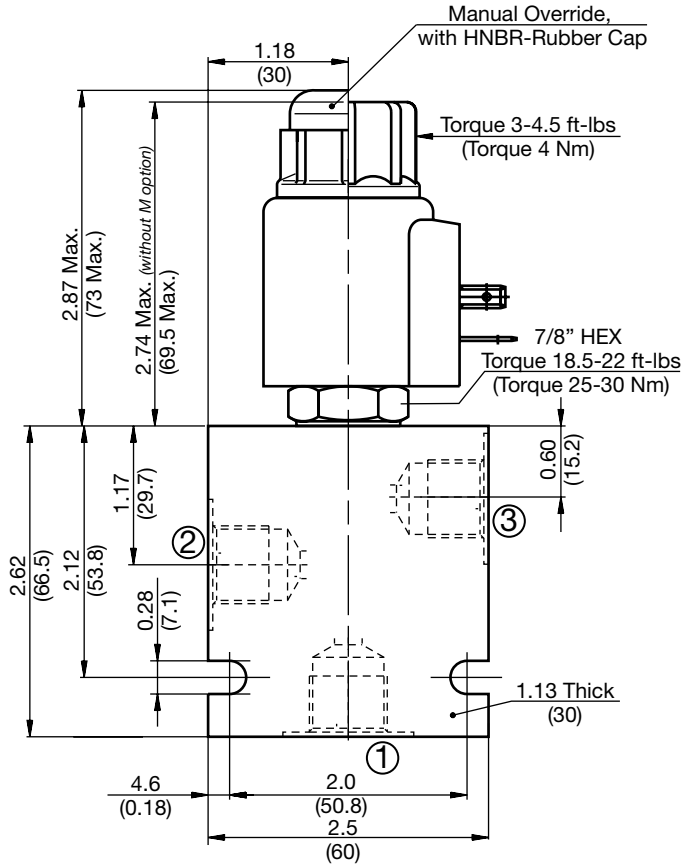

All measurements in inches (mm).  
Subject to technical modifications

## Model Code

**WK08C-01 M-C-N-24 DN**

### Valve Model

### Override Option

- blank = No manual override
- M = Manual override, push type

### Body & Ports

- C = Cartridge only
- AS6 = SAE-6 Ports, aluminum body
- SS6 = SAE-6 Ports, steel body

### Seals

- N = Buna-N
- V = Viton®

### Coil Voltage

- 0 = No coil, cartridge only

### DC

- 12 = 12 VDC
- 24 = 24 VDC
- 36 = 36 VDC
- 110 = 110 VDC (only available with connector DG)

### AC

- 24 = 24 VAC
- 115 = 115 VAC (AC coils internally full wave rectified)
- 230 = 230 VAC

### Coil Connector

- DC DG = EN 175301-803-A
- DS = Dual spade (SAEJ858a)\*
- DL = Leadwires (2) - 18" long (46 cm)\*
- DW = WeatherPak™ on leadwires - 9.5" long (24 cm)\*
- DN = Deutsch™ DT04-2P, molded, axial (IP69K Rated)\*
- DT = Amp Junior Timer™, molded, radial mount\*

### AC AG = EN 175301-803-A

### Coil Model 40-1836

For other coil connector types consult factory

\*Coils with internal diode are available, consult factory.

## Operating Limits

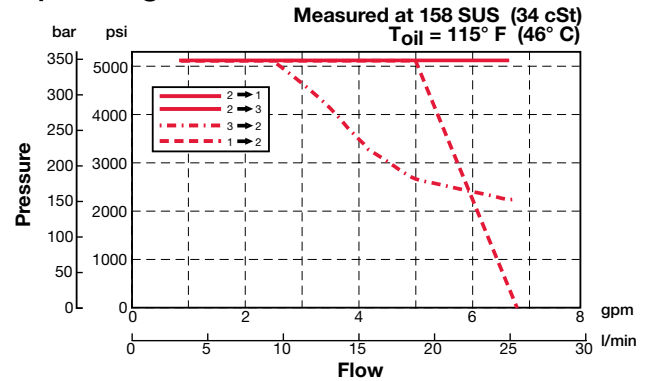

## Standard Line Bodies\*

Code	Part No	Material	Pressure Rating	Weight
FH083-AS6	03011424	Aluminum, anodized	3500 psi (245 bar)	0.58 lbs (0.26 kg)
FH083-SS6	00560920	Steel, zinc plated	6000 psi (420 bar)	1.7 lbs (0.77 kg)

\*Please refer to Line Bodies & Cavities section for details