



Electronic Temperature Switch ETS 3800 for Separate Temperature Probe

Description:

The ETS 3800 is a compact electronic temperature switch with a 4-digit display.

The version for a separate temperature probe has a measuring range of $-22..+302^{\circ}\text{F}$ and is used primarily with the TFP 100 temperature probe which was specially developed for tank installation.

It is also possible, however, to evaluate commonly-available PT 100 temperature probes.

Different output versions with one or two switching outputs, and with the possible option of an additional analog output signal, offer a variety of application possibilities.

The switching points and the associated hysteresis can be adjusted very quickly and easily using the keypad.

For optimum adaptation to the particular application, the instrument has many additional adjustment parameters (e.g. switching delay times, N/C / N/O function, etc.).

Special features:

- 2 switching outputs, up to 1.2 A load per output
- Optional analog output signal selectable (4 .. 20 mA / 0 .. 10 V)
- 4-digit digital display
- Optimum alignment - display can be rotated in two planes (axes)
- Switching / switch-back points and many useful additional functions can be set using keypad
- Display of temperature and unit of measurement in $^{\circ}\text{C}$ or $^{\circ}\text{F}$

Technical data:

Input data	
Measuring range ¹⁾	$-22..+302^{\circ}\text{F}$ ($-30..+150^{\circ}\text{C}$)
Connection, separate temperature probe	Female cable connection M12x1, 4 pole
Output data	
Accuracy (display, analog output)	$\pm 2.0^{\circ}\text{F}$ (+ PT100 error)
Temperature drift (environment)	$\leq \pm 0.0085\%$ FS/ $^{\circ}\text{F}$ max. zero point $\leq \pm 0.0085\%$ FS/ $^{\circ}\text{F}$ max. range
Analog output (optional)	
Signal	selectable: 4 .. 20 mA load resist. max. 500 Ω 0 .. 10 V load resistance min. 1 k Ω corresponds in each case to $-22..+302^{\circ}\text{F}$
Switch outputs	
Type	PNP transistor switching outputs
Switching current	max. 1.2 A per output
Switching cycles	> 100 million
Environmental conditions	
Ambient temperature range	$-13..+176^{\circ}\text{F}$ ($-13..+140^{\circ}\text{F}$ acc. to UL spec.)
Storage temperature range	$-40..+176^{\circ}\text{F}$
CE mark	EN 61000-6-1 / 2 / 3 / 4
UL mark ²⁾	Certificate No. E318391
Vibration resistance to DIN EN 60068-2-6 (0 .. 500 Hz)	≤ 10 g
Shock resistance to DIN EN 60068-2-29 (11 ms)	≤ 50 g
Protection class to IEC 60529	IP 67
Other data	
Supply voltage	9 .. 35 V DC without analog output 18 .. 35 V DC with analog output - limited energy - according to 9.3 UL 61010; Class 2; UL 1310/1585; LPS UL 60950
for use acc. to UL spec.	
Current consumption	max. 2.455 A total max. 35 mA with inactive switch outputs max. 55 mA with inactive switch outputs and analog output
Residual ripple of supply voltage	$\leq 5\%$
Display	4-digit, LED, 7 segment, red, height of digits 7 mm
Weight	~ 87 g

Note: Reverse polarity protection of the supply voltage, excess voltage, override and short circuit protection are provided.

FS (Full Scale) = relative to complete measuring range

¹⁾ Depending on the temperature range of the connected temperature sensor, the indication range of the ETS 3800 may be reduced.

²⁾ Environmental conditions according to 1.4.2 UL 61010-1; C22.2 No 61010-1

Setting options:

All the settings available on the ETS 3800 are combined in 2 easy-to-navigate menus. To prevent unauthorized adjustment of the instrument, a programming lock can be set.

Setting ranges of the switching points and switch-back hysteresis:

Switching point function

Unit	Switching point	Hysteresis	Increment*
°C	-27.0 .. 150.0	1.0 .. 178.0	0.5
°F	-17 .. 302	2 .. 320	1

Window function

Unit	Lower switch value	Upper switch value	Increment*
°C	-27.0 .. 146.5	-25.5 .. 148.0	0.5
°F	-17 .. 296	-14 .. 298	1

* All ranges given in the table are adjustable by the increments shown.

Additional functions:

- Switching mode of the switching outputs adjustable (switching point function or window function)
- Switching direction of the switching outputs adjustable (N/C or N/O)
- Switch-on and switch-off delay adjustable from 0.00 .. 99.99 seconds
- Choice of display (actual temperature, peak temperature, switching point 1, switching point 2, display off)

Pin connections:

M12x1, 4 pole

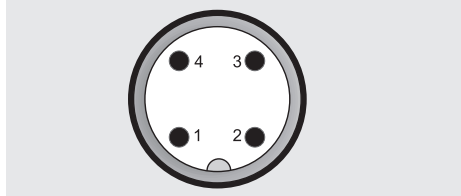

Pin	ETS 3866-2	ETS 3866-3
1	+U _B	+U _B
2	SP 2	Analog
3	0 V	0 V
4	SP 1	SP 1

M12x1, 5 pole

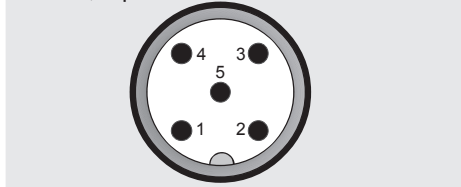

Pin	ETS 3868-5
1	+U _B
2	Analog
3	0 V
4	SP 1
5	SP 2

Model code:

ETS 3 8 6 X - X - 000 - 400

Mechanical connection

6 = Female cable connection M12x1, 4 pole

Electrical connection

6 = Male M12x1, 4 pole

only possible on output models "2" and "3"

8 = Male M12x1, 5 pole

only possible on output model "5"

Output

2 = 2 switching outputs

only in conjunction with electrical connection type "6"

3 = 1 switching output and 1 analog output

only in conjunction with electrical connection type "6"

5 = 2 switching outputs and 1 analog output

only in conjunction with electrical connection type "8"

Probe length in mm

000 = Separate temperature probe

Modification number

400 = Standard in °F

Accessories:

A male cable connector M12x1, 4 pole, to connect the separate temperature probe and a 3 m sensor cable, LIYCY 4 x 0.25 mm² are supplied with the instrument. Other accessories, such as electrical connectors, splash guards, clamps for wall-mounting, etc. can be found in the Accessories brochure.

Separate temperature probe:

(not supplied with the instrument)

- TFP 104 - 000 with male electr. conn. 4 pole Binder series 714 M18 Part no. 904696 (connector supplied)
- TFP 106 - 000 with male electr. conn. 4 pole M12x1 Part no. 921330 (connector not supplied)
- Tank installation sleeve for TFP 100 Part no. 906170

Dimensions:

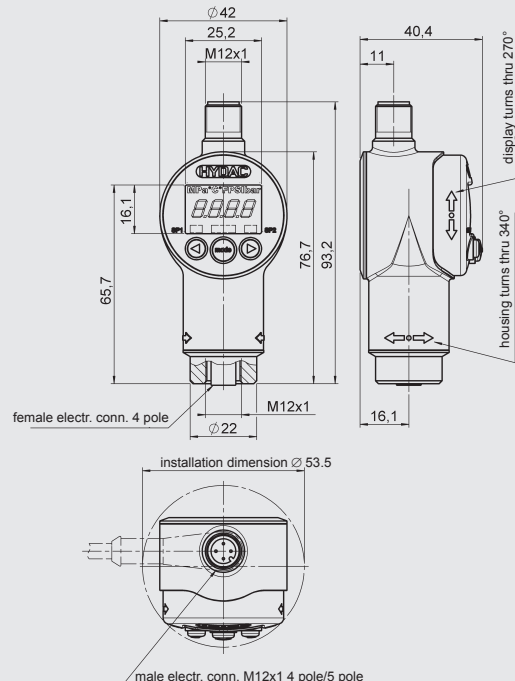

Note:

The information in this brochure relates to the operating conditions and applications described. For applications or operating conditions not described, please contact the relevant technical department. Subject to technical modifications.

HYDAC ELECTRONICS

90 Southland Dr. Bethlehem, PA 18017

Telephone +1 (610) 266-0100

E-mail: electronics@hydacusa.com

Internet: www.hydacusa.com