



Electronic Speed Sensor HSS 120

Description:

The contact-free speed sensors of the HSS 120 series detect the movement of ferromagnetic structures, such as gear wheels, gear rims or perforated discs, using the changes in magnetic flux.

So each sensor has two Hall elements and the differential between the two signals is detected, evaluated and then converted into an output signal suitable for processing.

The instruments are available for different insertion depths. For integration into standard controls, standard output signals are available.

Due to their extremely compact design, the robust housing and protection class IP 69K, the instruments can be used in almost any application and any mounting position.

The main fields of application are detection of speed and rotation direction on gear wheels with a small module and high resolution, especially in vehicles and mobile machines with hydraulic drives.

Special features:

- 2-channel Hall differential sensor
- Wide frequency range
- Alignment required when installing
- Large air gap

Technical data:

| Input data | |
|--|---|
| Frequency range | 0.1 .. 20,000 Hz |
| Probe length | 30; 35; 45 mm |
| probe diameter | 15 / 12 mm |
| Max. pressure on sensing surface | 217.55 psi, dynamic |
| Air gap / installation distance | Probe length: 30 mm 35 / 45 mm Module 1: 0.2 .. 1.0 mm 0.2 .. 1.3 mm Module 1.25: 0.2 .. 1.5 mm 0.2 .. 1.8 mm Module 1.5: 0.2 .. 1.7 mm 0.2 .. 2.0 mm Module 2: 0.2 .. 2.2 mm 0.2 .. 2.5 mm Module 2.5: 0.2 .. 3.2 mm 0.2 .. 3.5 mm |
| Mechanical connection | Flange, single, asymmetrical, cable outlet 90° (30 mm) / axial (35, 45 mm) |
| Type of installation | Dependent on direction (with asymmetrical flange) |
| Torque value | 10 Nm |
| Housing material | Brass |
| Seal | FPM |
| Output data | |
| Variant | 2-channel speed (90° / 270° phase shift for module 2) |
| Type | 2 NPN frequency outputs |
| Switching capacity | ≤ 50 mA ≥ 10 kΩ ohmic load ≤ 2.2 nF capacitive load |
| Direction of rotation | Flange on left, gear turns to right: channel A lagging; channel B leading |
| Signal level | LOW: ≤ 0.5 V HIGH: +U _B |
| Environmental conditions | |
| Operating temperature range | -40 .. +284 °F (-40 .. +320 °F for max. 500 operating hours) |
| Media resistance of housing | Salt water; various hydraulic oils; diesel oils; cleaning agent; salt spray |
| CE mark | DIN EN 60947-5-2 |
| Vibration resistance to EN 60068-2-64 | 30 g, 10 .. 500 Hz, 100 min in each direction |
| Shock resistance to EN 60068-2-27 / -29 | 50 g, 11 ms, 3x in each direction 100 g, 6 ms, 3x in each direction |
| Protection class to IEC 60529 to ISO 20653 | IP 67 IP 69K |
| Other data | |
| Electrical connection | Flying leads, 4-core, cable length 1 m |
| Supply voltage | 7 .. 30 V DC |
| Residual ripple of supply voltage | ≤ 5 % |
| Current consumption | < 30 mA at 30 V DC |
| Average life expectancy | 200,000 h (MTTF) |
| Weight | ~ 80 g |

Note: Reverse polarity protection of the supply voltage and short circuit protection (max. 50 mA) are provided

Pin connections:

| | |
|-------|-----------------|
| Core | HSS 120-2 |
| brown | +U _B |
| blue | Frequency 1 (A) |
| black | 0 V |
| white | Frequency 2 (B) |

Adjustment angle for other modules:

It is possible to achieve a 90° phase shift of the two frequency signals by turning the sensor through the angle indicated in the table below.

| | |
|------|-----------------|
| | |
| -20° | Module 1 |
| -15° | Module 1.25 |
| -10° | Module 1.5 |
| ± 0° | Module 2 ± 0° |
| | Module 2.5 +15° |

Specification for installation cavity:

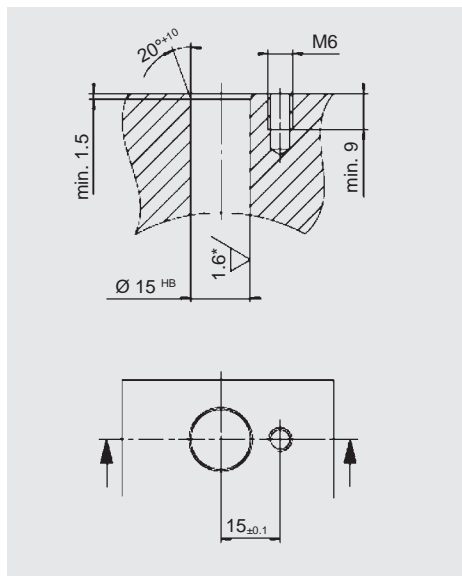

* For sealing function RA 1.6, otherwise 3.2

Model code:

HSS 1 2 0 - 2 - XXX - 000

Signal technology

2 = Outputs 1 and 2: Frequency (90° phase shift)

Probe length

030 = 30 mm

035 = 35 mm

045 = 45 mm

Modification number

000 = Standard

Dimensions:

Probe length (A): 35 mm, 45 mm

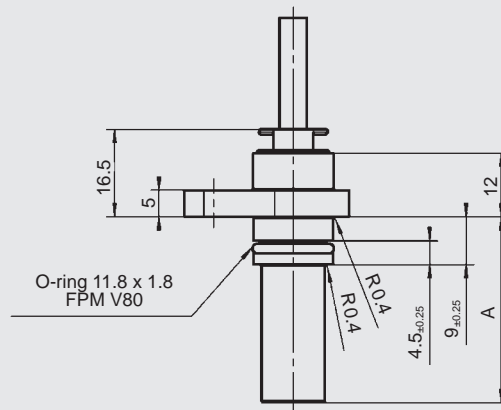
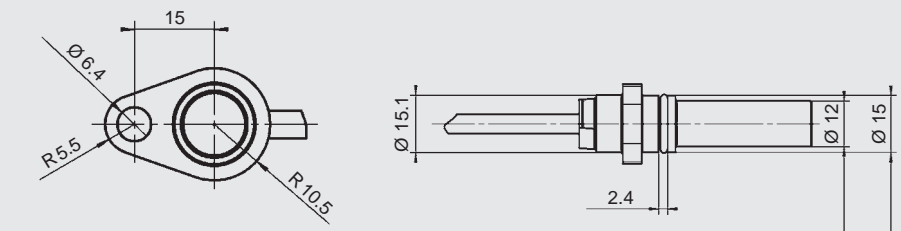

Probe length: 30 mm

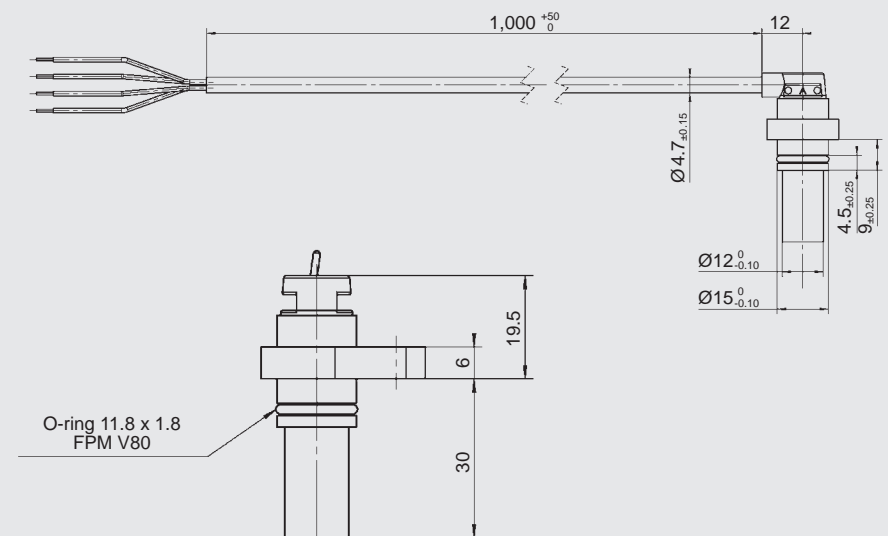

Note:

The information in this brochure relates to the operating conditions and applications described. For applications and operating conditions not described, please contact the relevant technical department. Subject to technical modifications.

HYDAC ELECTRONICS

90 Southland Dr. Bethlehem, PA 18017
Telephone +1 (610) 266-0100
E-mail: electronics@hydacusa.com
Website: www.hydacusa.com