



Electronic Speed Sensor HSS 130

Description:

The contact-free speed sensors of the HSS 130 series detect the movement of ferromagnetic structures, such as gear wheels, gear rims or perforated discs, using the changes in magnetic flux.

So each sensor has two Hall elements and the differential between the two signals is detected, evaluated and then converted into an output signal suitable for processing.

The instruments are available in different insertion depths. For integration into standard controls, standard output signals are available.

Due to their extremely compact design, the robust housing and protection class IP 69K, the devices can be used in almost any application and any mounting position.

These devices are mainly used for detection of speed and rotation direction on rotary sensors, also under extreme environmental conditions.

Special features:

- 2-channel Hall differential sensor
- Single-core seal
- Very high EMC resistance
- Large air gap

Technical data:

Input data	
Frequency range	0.1 .. 20,000 Hz
Probe length	16; 32 mm
probe diameter	18 mm
Max. pressure on sensing surface	145.04 psi, dynamic
Air gap / installation distance	Module 1: 0.2 .. 1.3 mm Module 1.25: 0.2 .. 1.8 mm Module 1.5: 0.2 .. 2.0 mm Module 2: 0.2 .. 2.5 mm Module 2.5: 0.2 .. 3.5 mm
Mechanical connection	Double flange, asymmetrical, cable outlet at 90°
Type of installation	Dependent on direction (with asymmetrical flange)
Torque value	10 Nm
Housing material	Brass / plastic (PA6 GF30)
Seal	FPM
Output data	
Variants	2-channel speed (90° phase shift) or 2-channel speed / direction of rotation
Types	2 NPN frequency outputs or 1 NPN frequency output + 1 NPN direction of rotation output
Switching capacity	≤ 500 mA
Direction of rotation	Cable outlet at 90°, gear rotation to right: channel A leading; channel B lagging or rotational direction signal (right: HIGH / left: LOW)
Signal level	LOW: ≤ 2 V HIGH: ≥ U _B - 2 V
Environmental conditions	
Operating temperature range	-40 .. +257 °F
Media resistance of housing	Saltwater, various hydraulic oils
CE mark	DIN EN 60947-5-2
Vibration resistance to EN 60068-2-36	5 .. 57 Hz (1.5 mm p-p) 57 .. 2000 Hz (10 g)
Shock resistance to EN 60068-2-27	15 g, 11 ms, in each direction 25 g, 6 ms, in each direction
Protection class to IEC 60529 to ISO 20653	IP 67 IP 6K9K
Other data	
Electrical connection	Flying leads, 4-core, 43 cm cable length
Supply voltage	8 .. 32 V DC
Residual ripple of supply voltage	≤ 5 %
Current consumption	< 33 mA at 24 V, both outputs LOW < 23 mA at 24 V, both outputs HIGH
Average life expectancy	120,000 h (MTTF)
Weight	~ 110 g

Note: Reverse polarity protection of the supply voltage and short circuit protection are provided.

Pin connections:

Core	HSS 130-2	HSS 130-3
brown	+U _B	+U _B
blue	0 V	0 V
black	Frequency 1	Frequency
white	Frequency 2	Direction of rotation

Adjustment angle for other modules:

It is possible to achieve a 90° phase shift of the two frequency signals by turning the sensor through the angle indicated in the table below.

-12°	Module 1	
- 9°	Module 1.25	
- 7°	Module 1.5	
- 3°	Module 1.75	
± 0°	Module 2	± 0°
	Module 2.25	+ 4°
	Module 2.5	+ 8°
	Module 2.75	+13°
	Module 3	+17°

Specification for installation cavity:

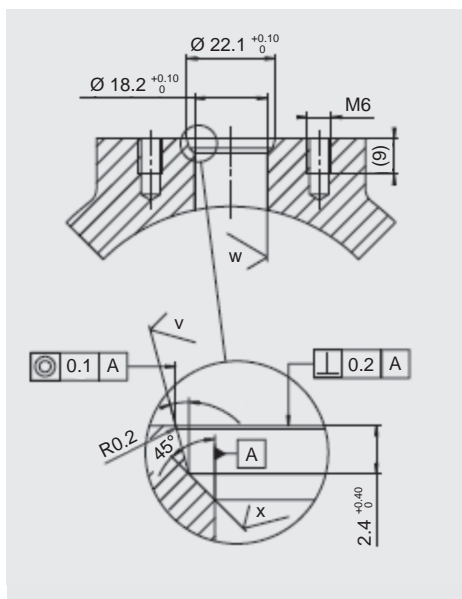

- General tolerances for chipping processes: ISO 2768-mH
- Tolerance: ISO 8015
- Surface quality: ISO 1302

Model code:

HSS 1 3 0 - X - XXX - 000

Signal technology

- 2 = Outputs 1 and 2: Frequency (90° phase shift)
- 3 = Output 1: Frequency
Output 2: Direction of rotation

Probe length

- 016 = 16 mm
- 032 = 32 mm

Modification number

- 000 = Standard

Dimensions:

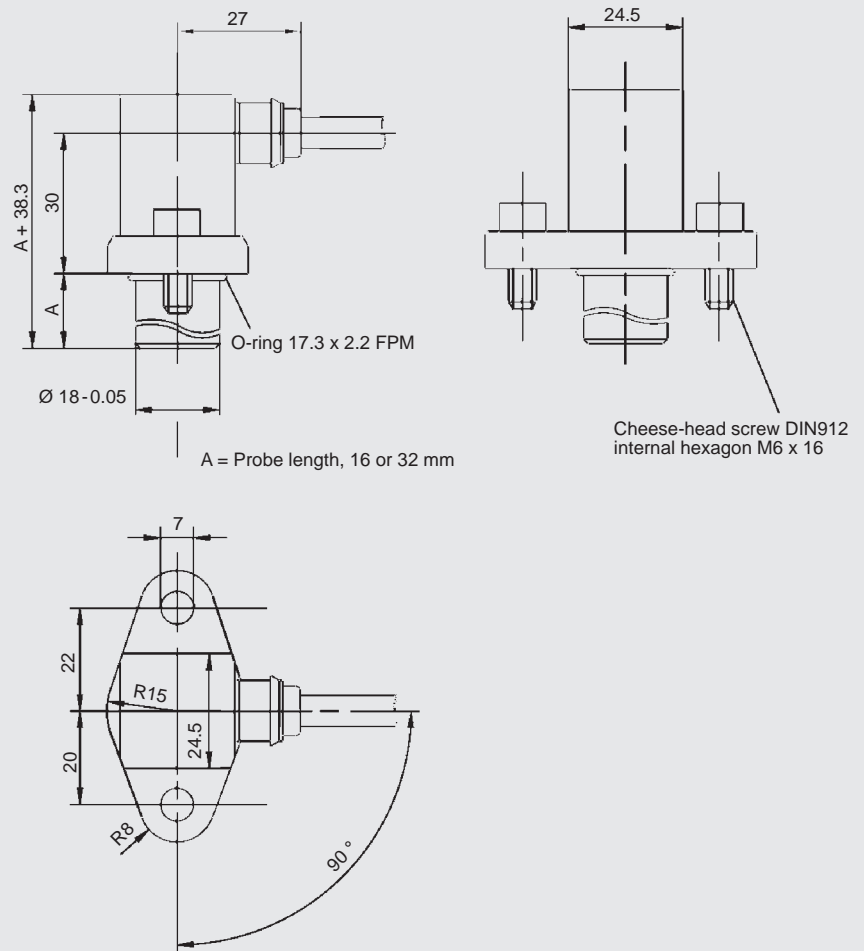

Note:

The information in this brochure relates to the operating conditions and applications described. For applications and operating conditions not described, please contact the relevant technical department. Subject to technical modifications.

HYDAC ELECTRONICS
90 Southland Dr. Bethlehem, PA 18017
Telephone +1 (610) 266-0100
E-mail: electronics@hydacusa.com
Website: www.hydacusa.com