

**HYDAC** INTERNATIONAL

**Fluid Analysis Services**  
Clean Oil For Predictive Maintenance

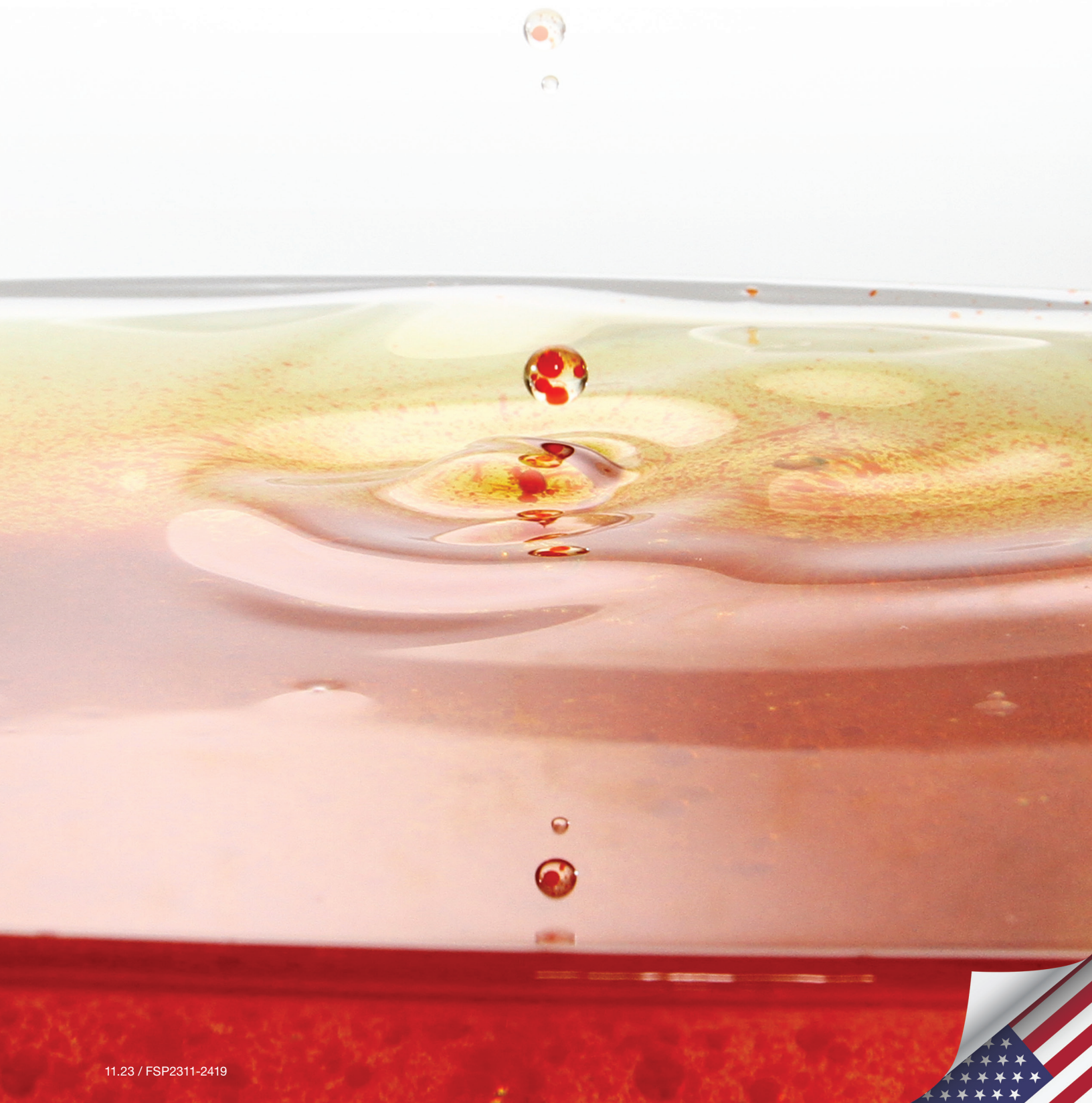

# FLUID ANALYSIS SERVICES

Oil analysis is a condition monitoring tool designed to monitor:

- Fluid properties, or the condition of the oil and the additives
- Fluid contamination
- Machine wear

## What is the purpose of taking oil samples?

Oil samples can provide insight into the fluid and machine condition at a given point in time. Proper sampling is important in the process of taking bottle samples. The sample taken needs to be representative of the fluid in the system as it is only a small sample of the total oil volume present. Proper sampling of system is dependent upon the following factors:

- Sampling point location
- Sampling equipment used to take the sample
- Sampling method
- Frequency of sampling
- Recent maintenance completed on the system



## DO's and DON'T's for Oil Sampling

- ✓ **DO** sample from running machines.
- ✗ **DO NOT** sample “cold” systems.
  - Best time to sample a system is when the system is under normal working load and normal conditions.
- ✓ **DO** sample upstream of filters and downstream of machine components.
  - Taking a sample before and after a filter for a simple particle count will allow you to see how well the filter is currently operating.
- ✓ **DO** create specific written procedures for each system sampled.
  - Identify the sample location
  - Amount of flush volume
  - Frequency of sampling
  - Timing within a cycle to sample
  - Indicate what tools and accessories to use on that specific sample point based on lubricant type, pressure and amount of fluid required.
- ✓ **DO** ensure that sampling valves and sampling devices are thoroughly flushed prior to taking the sample.
  - Cross-contamination has always been a problem in oil sampling. Failure to flush the sample location properly will produce a sample with a high degree of noise.
- ✓ **DO** ensure that samples are taken at proper frequencies.
- ✗ **DO NOT** sample “as time permits”.
  - Setting up the appropriate sampling frequency and adhering to it will allow for precise analysis and sound maintenance decisions.
- ✓ **DO** forward samples immediately to the oil analysis lab after sampling
  - If a problem is detected in a system, the earlier it is detected, the less catastrophic potential it may have.

## Oil Sampling Location

In addition to using a clean oil sample bottle, any sampling equipment must also be clean. New microbore hose should be used with each sample that is taken to avoid cross contamination of the sample. The sample needs to be taken from an area of turbulent flow rather than a stagnant location.

Turbulent flow ensures that the sample taken is representative of the fluid in the reservoir.

Samples can be taken from a Sampling or Test Point that can be accessed with a sampling probe or a hand-held vacuum pump. The test point should be one that has been permanently installed at a location where such turbulent flow exists. The test point should be flushed prior to filling the sample bottle per the method outlined below.

Samples can also be taken directly from the hydraulic reservoir using a sampling tube. The sample should be taken a mid point of the reservoir to ensure a representative sample is taken. Samples taken from the top of the reservoir will be significantly cleaner while samples from the bottom of the reservoir will contain significantly higher amounts of contamination.



## Oil Sampling Procedure – ISO4021

- Clean all surfaces of sampling point thoroughly
- Operate system for minimum 30 minutes
- Open lock or throttle valve, adjust a flow of about 500 ml/min, flush sampling point with minimum 1 litre (capture oil in a waste reservoir)
- Open lid of sampling bottle now, hold bottle downwards until sampling, fill bottle to 75% level, close lid immediately after sampling. Do not touch sampling outlet in the meantime!
- Close lock or throttle valve
- Label bottle (date, number, fluid type, fluid temperature,

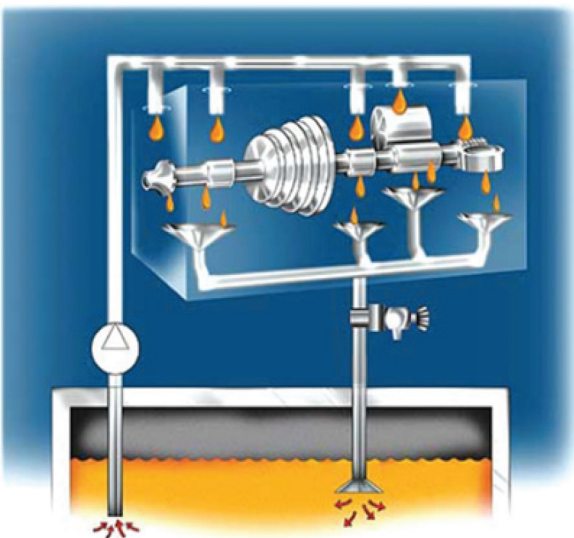
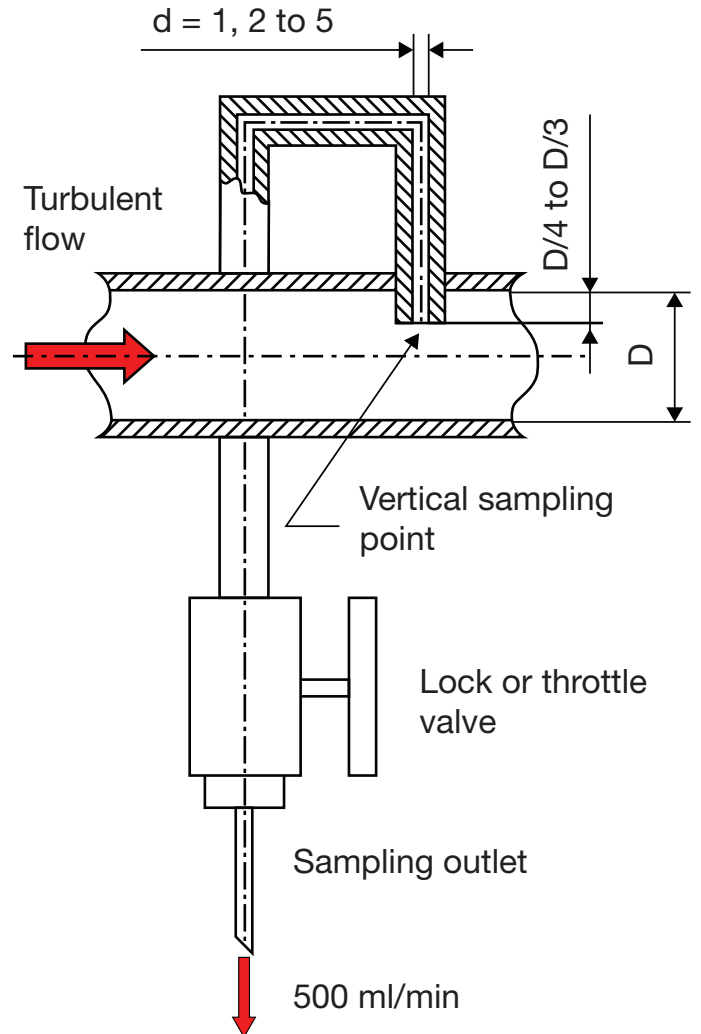
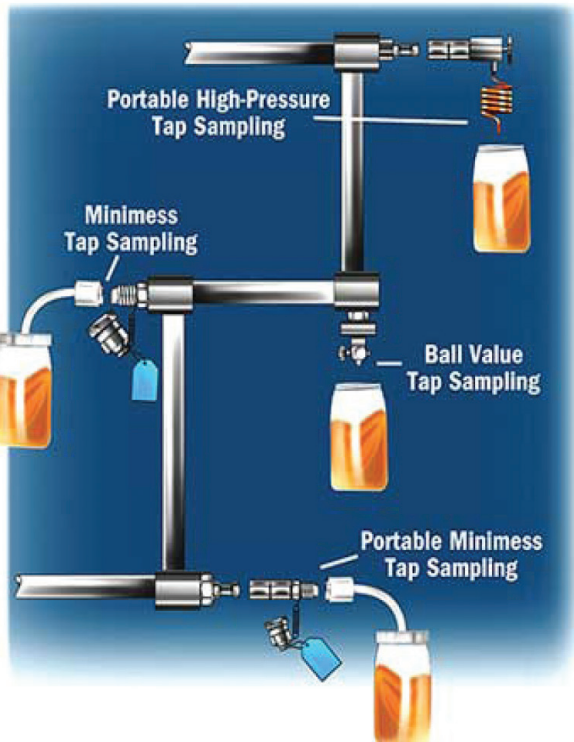

Figure 2. Return or Drain Line

# FLUID ANALYSIS SERVICES

## Introduction

Clean oil is the key to long equipment life, precision operation, lower maintenance costs and decreased downtime. HYDAC's Fluid Analysis Services can unlock the door to increased savings by detecting potential problems early, so that service/downtime can be scheduled and catastrophic failures/costs can be avoided.

**HYDAC's** Fluid Analysis Services provide users of industrial and mobile hydraulic equipment with a complete analytical report including:

- System status (rated as Normal, Caution or Critical).
- Graphs of sample and limit data for easy detection of abnormal results.
- Comments and recommendations (where applicable).
- Photo of the contamination contained in the current oil sample. Kits including patch photo are available.
- An oil analysis report will be sent via email to the address provided on the component registration form or is readily available on-line
- Early warning limits based on industry standards, provided targets or a provided baseline.
- Current sample data displayed with up to 10 previous sample results.

## A Typical Fluid Analysis Program

**HYDAC's** Fluid Analysis Services can be used to implement a preventative maintenance program for each critical piece of equipment. The program should begin with a complete examination of the equipment by the customer to determine system criticality and sensitivity, as well as collecting a baseline sample to compare against.

## New Oil/Baseline Samples

A sample of new oil should be sent to the lab for analysis. This sample will act as a baseline for comparison with subsequent sample results. New oil/Baseline samples should be taken from the tote after filtering, this will provide the most accurate representation of the oil properties before it is used.

Below is a listing of commonly cited sampling frequencies. These are given as a starting point only. Sampling frequency should be increased as environment severity and system criticality increases.

## Sampling Frequency

Equipment Type	Hours
Hydraulics - Industrial	700
Hydraulics - Mobile	200
Hydraulics - Aviation	150
Steam Turbines	500
Transmissions	300
Air/Gas Compressors	500
Chillers	500
Gear Boxes - High Speed/Duty	300
Gear Boxes - Low Speed/Duty	1000
Bearings - Journal and Rolling Element	500

## Sampling Information

The Fluid Analysis Sample Form must be filled out as completely and accurately as possible. Accurate laboratory assessment of your sample depends on it. The most important information is:

- Your Company
- Your Name
- Your Email / Contact Information
- Unit ID / Name
- Date of Sample
- Type of oil (*Manufacturer & Brand*) should be included for most accurate information about your oil sample

HYDAC's Fluid Analysis Services offer our customers a valuable means of extending equipment life, lowering maintenance costs, and decreasing downtime by improving overall system performance using preventative maintenance strategies. To choose the correct program for you please contact your HYDAC distributor or HYDAC directly.

## HYDAC Sample Kits and Laboratory Reports

### Prepaid Sample Kits

Our Fluid Analysis Service includes testing for mineral oil based fluids, water glycol fluids, grease testing, MPC varnish potential testing, and diesel fuel test kits. Each kit is supplied with a clean sample bottle with mailer bottle, component registration form and prepaid Fluid Analysis Service.

### Fluid Analysis Laboratory Reports

For each sample submitted to the lab, our customers will receive complete analytical lab reports including system status and recommendations.



## Understanding Your Fluid Analysis Laboratory Report

### Status and Recommendations

Corrective actions are recommended when applicable. The status of the sample is rated in three categories:

- **Normal**
  - System is operating within the parameters established by provided limits and/or baseline data.
  - System requires no immediate action.
- **Caution**
  - System is operating outside of caution limits in one or more areas.
  - System requires scheduled maintenance.
- **Critical**
  - System is operating outside of critical limits in one or more areas.
  - System requires immediate attention.

### Fluid Laboratory Tests

Using a 100 mL minimum sample, the following tests can be performed:

#### Particle Count

- Particle Count – ISO CODE representing the number of particles of solid contamination present in a given oil sample
- Water Content – Determination of the amount of water present in a given sample; reported as ppm or percent
- Viscosity – Physical property of a given oil where changes can indicate extent of contamination or degradation; Reported in cSt at 40°C
- TAN – Total Acid Number – Determination of presence of oxidation/organic acids leading to oil degradation; Reported as mg KOH/g
- Spectrographic Analysis – Concentration of additive components, wear metals and contaminate levels reported as ppm

# ISO 4406

Most Sensitive System Component	Low/Medium Pressure Under 2000 psi (moderate conditions)		High Pressure 2000 to 2999 psi (low/medium with severe conditions*)		Very High Pressure 3000 psi and over (high pressure with severe conditions*)	
	ISO Target Levels	Micron Ratings	ISO Target Levels	Micron Ratings	ISO Target Levels	Micron Ratings
<b>Pumps</b>						
Fixed Gear or Fixed Vane	20/18/15	20	19/17/14	10	18/16/13	5
Fixed Piston	19/17/14	10	18/16/13	5	17/15/12	3
Variable Vane	18/16/13	5	17/15/12	3	<i>not applicable</i>	<i>not applicable</i>
Variable Piston	18/16/13	5	17/15/12	3	16/14/11	3**
<b>Valves</b>						
Check Valve	20/18/15	20	20/18/15	20	19/17/14	10
Directional (solenoid)	20/18/15	20	19/17/14	10	18/16/13	5
Standard Flow Control	20/18/15	20	19/17/14	10	18/16/13	5
Cartridge Valve	19/17/14	10	18/16/13	5	17/15/12	3
Proportional Valve	17/15/12	3	17/15/12	3	16/14/11	3**
Servo Valve	16/14/11	3**	16/14/11	3**	15/13/10	3**
<b>Actuators</b>						
Cylinders, Vane Motors, Gear Motors	20/18/15	20	19/17/14	10	18/16/13	5
Piston Motors, Swash Plate Motors	19/17/14	10	18/16/13	5	17/15/12	3
Hydrostatic Drives	16/15/12	3	16/14/11	3**	15/13/10	3**
Test Stands	15/13/10	3**	15/13/10	3**	15/13/10	3**
<b>Bearings</b>						
Journal Bearings	17/15/12	3	—	—	—	—
Industrial Gearboxes	17/15/12	3	—	—	—	—
Ball Bearings	15/13/10	3**	—	—	—	—
Roller Bearings	16/14/11	3**	—	—	—	—

\* Severe conditions may include high flow surges, pressure spikes, frequent cold starts, extremely heavy duty use, or the presence of water.

\*\* Two or more system filters of the recommended rating may be required to achieve and maintain the desired Target Cleanliness Level.

# FLUID ANALYSIS SERVICES

## Fluid Laboratory Services List

HYDAC offers various types of prepaid sample kits to meet your different testing requirements.

The purchase price of each kit includes:

- All costs of analysis
- Sample bottle, sampling instructions, fluid analysis sample form, shipping canister
- Computerized data storage, trending report (up to 3 years).

### Premium Oil Analysis Kit without Patch Photo

This kit is designed to include all relevant tests.

Tests include:

- Particle Count
- Water Content by Karl Fisher
- Total Acid Number
- Viscosity
- Spectrographic Analysis

Kit Type	Part Number
Box of 10 Sample Bottle Kit	2702060

### Premium Oil Analysis Kit with Patch Photo

This kit is designed to include all relevant tests.

Tests include:

- Particle Count
- Water Content by Karl Fisher
- Total Acid Number
- Viscosity
- Patch Test/Photo
- Spectrographic Analysis

Kit Type	Part Number
Box of 10 Sample Bottle Kit	2095151

### Water Glycol Analysis Kit

This kit is designed exclusively for water glycol systems. Contamination, water content and viscosity are monitored.

Tests include:

- Water Content by Karl Fisher
- Viscosity
- Patch Test/Photo
- Estimated ISO 4406 cleanliness code

Kit Type	Part Number
Water Glycol Analysis Kit	2702057

### Basic Grease Testing Kit

This kit is designed for testing greases commonly used in plant applications.

Tests include:

- Color – ASTM D7918
- Ferrous Debris
- Full FTIR Spectrum Scan
- Water Percent
- Grease Kit with sampler and soft mailer

Kit Type	Part Number
Basic Grease Testing Kit	2215398

### MPC Varnish Potential Analysis Kit

This kit is for determination of fluid potential for developing varnish.

Tests include:

- MPC Varnish Test

Kit Type	Part Number
MPC Varnish Potential Analysis Kit	2703453

### Fluid Analysis Sets

The Fluid Analysis Set from HYDAC provides the necessary tools to determine levels of solid particulate contamination present in a particular fluid sample. Using the vacuum pump contained in the kit, the fluid sample is drawn through a membrane patch. The residual dirt left on the patch is viewed under a microscope and compared to photos of known contamination levels in the HYDAC Contamination



Handbook (included) for a visual assessment.

Tests include:

- Hand-held vacuum pump
- Syringe, 30 mL
- Disposable Petri Dishes
- Forceps
- Membrane patches, 0.45 µm, 25 mm, (100 pack)
- Membrane patches, 0.8 µm, 25 mm, (100 pack)
- Carrying Case
- Microscope, 10x - 200x
- Plastic funnel
- Solvent dispenser bottle
- Solvent Dispenser bottle cap
- Plastic sample bottle, 4 oz.
- Solvent patch holder
- Tubing, Tygon 3"
- 10' section of 1/4" LDPE tubing
- Fluid Control Contamination Handbook!

Kit Type	Part Number
Fluid Analysis Kit	2086847



Global Headquarters  
HYDAC INTERNATIONAL  
GMBH

Industriegebiet  
D – 66280 Sulzbach/Saar  
Germany

Tel.: +49 6897 509-01

Fax: +49 6897 509-577

Internet: [www.hydac.com](http://www.hydac.com)  
Email: [info@hydac.com](mailto:info@hydac.com)

## North America Locations

### USA

[www.HYDAC.com/EN-US](http://www.HYDAC.com/EN-US)

**North America Headquarters**  
**HYDAC TECHNOLOGY CORPORATION**  
**Filter Division**

2260 City Line Road  
Bethlehem, PA 18017  
**+1.610.266.0100**

**HYDAC TECHNOLOGY CORPORATION**  
**Electronic Division**  
**Process Filter Division**

**HYDAC CORPORATION**  
**Accumulator Division**  
90 Southland Drive  
Bethlehem, PA 18017  
**+1.610.266.0100**

**HYDAC TECHNOLOGY CORPORATION**  
**Accessory Division**

2204 Avenue C  
Bethlehem, PA 18017  
**+1.610.266.0100**

**HYDAC TECHNOLOGY CORPORATION**  
**Filter System Division**  
**Process Filter Division**  
**Fuel Filtration Division**

580 West Park Road  
Leetsdale, PA 15056  
**+1.724.318.1100**

**HYDAC TECHNOLOGY CORPORATION**  
**Hydraulic Division –**  
**Compact Hydraulics**

450 / 445 Windy Point Drive  
Glendale Heights, IL 60139  
**+1.630.545.0800**

**HYDAC TECHNOLOGY CORPORATION**  
**Hydraulic Division – Tech Center**

430 Windy Point Drive  
Glendale Heights, IL 60139  
**+1.630.545.0800**

**HYDAC TECHNOLOGY CORPORATION**  
**Cooling System Division**

1051 Airlie Parkway  
Denver, NC 28037  
**+1.610.266.0100**

**HYDAC TECHNOLOGY CORPORATION**  
**Mobile Hydraulic Division**

4047 Lincoln Way E • Building D  
Wooster, OH 44691  
**+1.610.266.0100**

**HYDAC CYLINDERS LLC**

540 Carson Road North  
Birmingham, AL 35217  
**+1.205.520.1220**

**HYDAC TECHNOLOGY CORPORATION**  
**HYDAC CORPORATION**  
**Sales Office & Operations**

510 Stonegate Drive  
Katy, TX 77494  
**+1.281.579.8100**

**HYDAC TECHNOLOGY CORPORATION**  
**HYDAC CORPORATION**  
**NW Sales Office & Operations**

1201 NE 144th St. Bldg. B • Suite 111  
Vancouver, WA 98685  
**+1.610.266.0100**

**HYDAC TECHNOLOGY CORPORATION**  
**HYDAC CORPORATION**  
**NE Sales Office**

4047 Lincoln Way E • Building D  
Wooster, OH 44691  
**+1.610.266.0100**

**HYDAC TECHNOLOGY CORPORATION**  
**HYDAC CORPORATION**  
**SE Sales Office**

1051 Airlie Parkway  
Denver, NC 28037  
**+1.610.266.0100**

**HYDAC TECHNOLOGY CORPORATION**  
**HYDAC CORPORATION**  
**NC Sales Office**

300 N. Corporate Drive • Suite 215  
Brookfield, WI 53045  
**+1.610.266.0100**

### Canada

[www.HYDAC.com/EN-US](http://www.HYDAC.com/EN-US)

**HYDAC CORPORATION**

14 Federal Road  
Welland, Ontario, Canada L3B 3P2  
**+1.905.714.9322**

**HYDAC CORPORATION**  
**Sales Office**

5160 75 Street NW  
Edmonton, Alberta, Canada T6E 6W2  
**+1.780.484.4228**

**HYDAC CORPORATION**  
**Sales Office**

Montreal, Québec, Canada J2M 1K9  
**+1.877.539.3388**

### Mexico

**HYDAC INTERNATIONAL SA de CV**

Calle Alfredo A Nobel No 35  
Col Puente de Vigas  
Tlalnepantla, Edo Mexico  
CP 54090  
Mexico  
**+011.52.55.4777.1262**