

OFFLINE FILTRATION SYSTEMS

HFS-15 Series

Mobile Filter Unit



Hydraulic Schematic

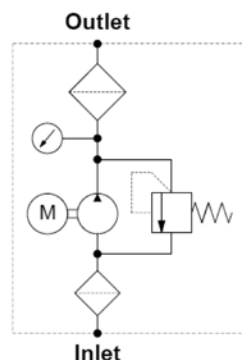

HFS-15-E-...

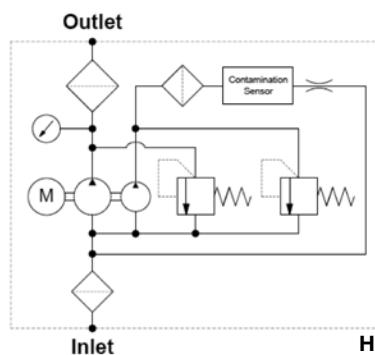

HFS-10-P-...

Description

The HFS Hand Held Portable filter unit is used as a service unit for filling hydraulic systems, flushing small hydraulic systems as well as for cleaning in bypass flow. Solid particle contamination as well as free water can be removed by the filter elements.

The HFS can also be supplied with a CS 1000 ContaminationSensor. This allows the solid particle contamination in the oil to be monitored at the same time. The cleanliness class results are displayed according to ISO and SAE classifications.

Features

- Improvement in service life for components and system filters
- Increased oil service life
- Increased machine availability
- Simple operation
- Compact design
- Integrated dry running protection
- Option: CS 1000 ensures continuous monitoring of oil cleanliness during cleaning

Applications

- Filtered and unfiltered filling of hydraulic systems
- Temporary offline filtration of hydraulic systems
- Filtered or unfiltered fluid transfer
- Unfiltered drainage of hydraulic tanks
- Leakage oil recirculation at test benches

Technical Specifications

Maximum Flow Rating	HFS-15-E-... 4 gpm (15 l/min; @ 50Hz)	HFS-10-P-... 2.6 gpm (10 l/min; @ 50Hz)
Pump type	Vane pump	
Maximum operating pressure	58 psi (4.0 bar)	
Maximum permissible inlet pressure	-5.8 to 8.7 psi (-0.4 bar to + 0.6 bar)	
Permissible viscosity range	HFS-15-E-... 42 SUS 1623 SUS (5 to 350cSt)	HFS-10-P-... 42 SUS 927 SUS (5 to 200cSt)
Length of power cable	9.8' (3 m) (incl. plug)	
Permissible fluid temp.	14-176°F (-10 ... +80 °C)	
Permitted ambient temperature range	14-104°F (-10 to +40°C)	
Seal material	FKM (Viton®)	
Empty weight	HFS-15-E-... 30.9 lb (14 kg)	HFS-10-P-... 36.4 lb (16.5 kg)
Hoses w/ crimped wands (standard)	Suction hose length: 8.2' (2.5m) Return hose length: 8.2' (2.5m) Hose material: PVC Wand material: Zinc-plated steel	

Model Code

HFS - 15 - E - 9 - NX - 10 - - E

- Series**
HFS = Mobile Filter Unit
- Size**
15 = 4 gpm (15 L/min) (for type "E" only)
10 = 2.6 gpm (10 L/min) (for type "P" only)
- Type**
E = Economy
P = Premium (with Condition Monitoring)
- Element length**
9 = 9"
- Filter Media**
NX = Particulate removal element
AM = Water Removal element
- Filtration Rating**
1, 3, 5, 10, 25
- Power supply**
OMIT = 120V-60Hz-1Ph (0.25kW)
M = 230V, 50Hz, 1pH (0.25kW)
- Clogging indicator**
E = Back-pressure indicator

Scope of delivery

- HFS (with filter element and hose/wand assembly)
- Operating and maintenance instructions

Filtration	Part no.	Filtration rating
HFS-15-001	7642315	1 µm
HFS-15-003	7642316	3 µm
HFS-15-005	7642317	5 µm
HFS-15-010	7642314	10 µm
HFS-15-025	7642318	25 µm
HFS15-AM	7642319	Water Removal

Hoses with threaded connection (depressurized suction up to max. 350 mm ² /s)				
Description	Part no.	Suction hose/ Pressure Hose	Thread	Material Section/ Pressure Hose
MFU-15-SKDK5F	4270516	2.5 m / 5 m	M30x2 / M26x1.5	1SN / 2TE

Accessories for hoses with threaded connection		
Description	Part no.	Function
MFU-15-SKDK-LF	4270559	Lance ¹ (length of 1.30 m)
MFU-15-SKDK-SF	4270560	Suction filter ¹
MFU-15-SKDK-ZWF	4270518	Counter
MFU-15-SKDK-ZPF	4270561	Pump nozzle ²
MFU-15-SKDK-ZPWF	4270519	Pump nozzle + counter ²

¹max. viscosity 200 mm²/S

²max. operation duration of the unit with closed pump nozzle of 5-10 min.

Dimensions – HFS-15E

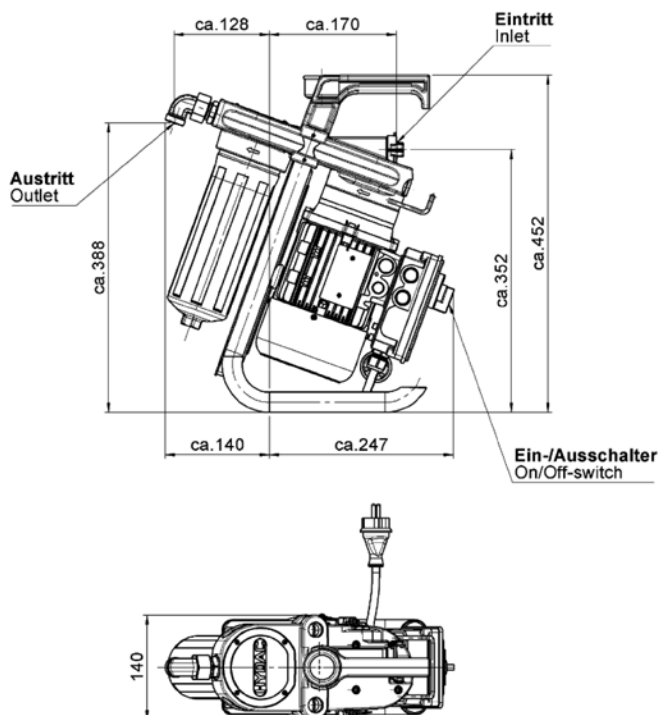

Dimensions – HFS-10P

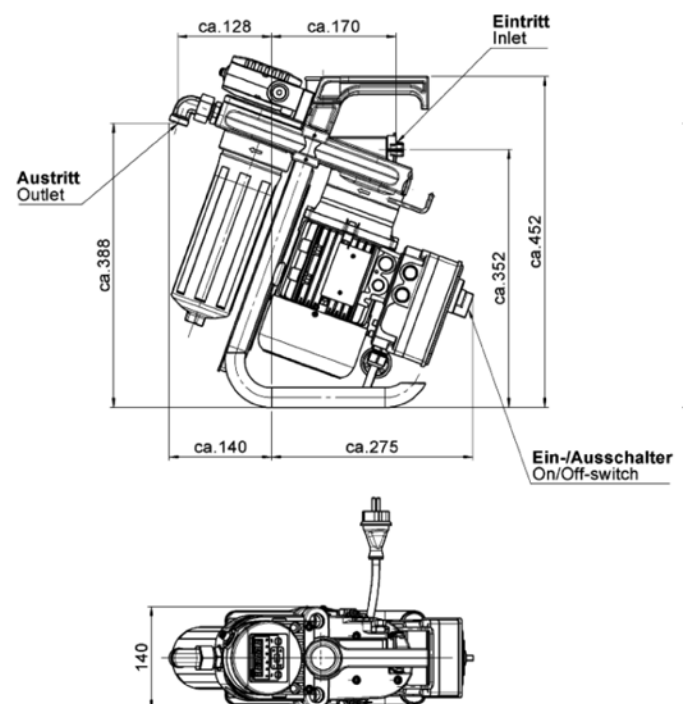

Dimensions are millimeters and for general information only, all critical dimensions should be verified by requesting a certified print.