

OFFLINE FILTRATION SYSTEMS

NAV Series

North American Vacuum Dehydrator



Description

The North American Vacuum Dehydrator (NAV) uses vacuum dehydrating technology to remove both free and dissolved water, and gases, from oil. In addition to water and gas, the NAV also removes solid contaminants from the oil with the use of highly efficient filter elements installed on the unit. The NAV is designed for use with larger applications, such as the conditioning of oil in larger hydraulic and lube reservoirs.

Features and Benefits

- Water Sensor standard on all units to show percent saturation
- Removes 100% of free and over 90% of dissolved water, as well as 100% of free and over 90% of dissolved gases
- Maintenance, operating, troubleshooting instructions are in HMI (touchscreen)
- Automatic mode enables user-defined system shutdowns
- Use of a low maintenance, dry running claw vacuum pump helps to avoid any dangerous, chemically reactive by-products

Applications

- Steel Mills
- Pulp and Paper Plants
- Power Generation Plants
- Any customer with a water problem in a large reservoir

Technical Specifications

Model	NAV30	NAV5
Overall Dimensions <i>(height x width x length)</i>	39" W x 76" L x 74" H	36" W x 67" L x 78" H
Dry Mass	1990 lbs (903 kg)	1500 lbs
Inlet Connections	2" NPT	1 1/2" NPT
Outlet Connections	1 1/2" NPT	1" NPT
Flow Rate	30 gpm (114 L/min)	5 gpm
Inlet Pressure	22 in. Hg - 10 psi	
Outlet Pressure	110 psi (7.6 bar)	
Fluid Service Temperature	39°F to 170°F (3.8°C to 77°C)	
Operating Temperature	39°F to 105°F (3.8°C to 40.6°C)	
Fluid Viscosity	150-3280 SUS (23-700 cSt)	
Power Supply	460V	
Attainable Water Content	<10ppm	
Relative Humidity Display	Standard, 0 - 99%	
Seals	FKM	
Constructions	Base Frame: Carbon Steel Vessel: Carbon Steel Seals: Viton	
Protection Class	NEMA 4	

Model Code

NAV - 30 - M - 2 - A - H - 10

Series

NAV = North American Vacuum Dehydrator

Flow Rate

30 = 30 gpm

5 = 5 gpm

Operating Fluid

M = Mineral Oils (including oils w/ max. Viscosity as identified in specifications)

Type

1 = Stationary

2 = Mobile

Voltage/Frequency

A = 460V / 60Hz / 3Ph+PE

Heater

H = Standard

Filtration Rating

3 = 3 Micron

5 = 5 Micron

10 = 10 Micron

25 = 25 Micron

Model Codes containing RED are non-standard items – Minimum quantities and longer lead times may apply - Contact HYDAC for information and availability

Dimensions

NAV North American Vacuum Dehydrator

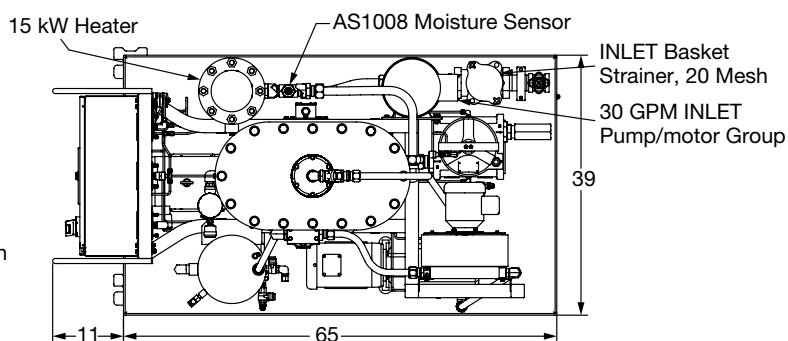
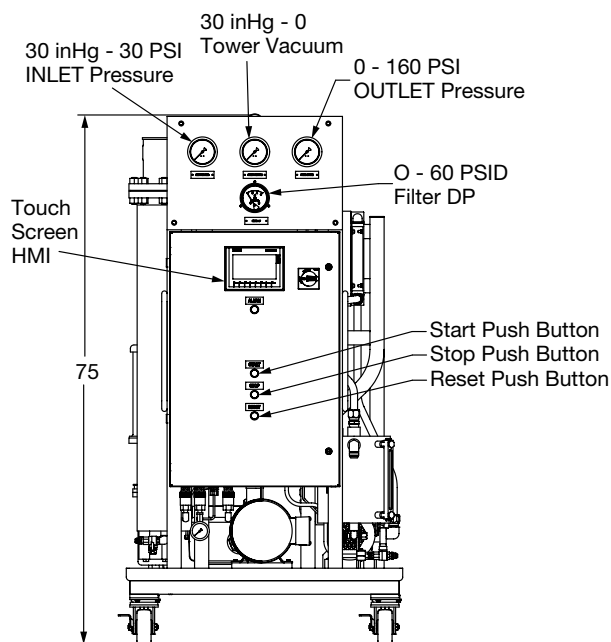

Dimensions are for general information only, all critical dimensions should be verified by requesting a certified print.