

# OFFLINE FILTRATION SYSTEMS

## OLF Compact Series



### Features

The OLF Compact filter is designed to be used offline to efficiently and cost effectively filter standard hydraulic oils which are highly contaminated. The OLF Compact is specifically designed to be used on hydraulic systems with a reservoir volume of up to 1000 gallons. The standard filters can be supplied as ready to install offline units complete with motor and pump units as shown or as individual filters.

### Benefits

- Lower operating costs
- Extended element service life
- Extended fluid life
- Cleaner, more efficient systems
- Incinerable elements
- Easy installation

### Applications

Typical applications include:

- Injection molding machinery
- Machine tools
- Gear boxes
- Mobile equipment
- Filtration of fluids for intermittently operated hydraulic systems and test stands

### Technical Specifications

Operating Range	
Viscosity: <i>(see pressure drop curves)</i>	to 700 SUS (150 cSt) (OLF-5) to 3000 SUS (650 cSt) (OLF-5/15) to 10,000 SUS (2160 cSt) (OLF-5/4)
Operating Pressure:	45 psi (3 bar) max up to 87 psi (-0.4 to 6 bar)
Suction Pressure:	11" Hg (-0.4 to 6 bar) max
Inlet Pressure <i>(Model with flow control valve):</i>	145 psi (10 bar) min / 725 psi (50 bar) max
Fluid Temperature:	32° to 175°F (0 to 80°C)
Ambient Temperature:	-4° to 104°F (-20 to 40°C)
Seals:	NBR <i>(standard)</i>
Maximum Flow Rate:	OLF-5 = 1.6 gpm (6.1 lpm) OLF-5/15 = 4.9 gpm (18.6 lpm) OLF-5/4 = 1.3 gpm (4.9 lpm)
Fluids	Standard Mineral Oils / Water/Oil based fluids <i>(Minimum 40% Oil in Fluid)</i> <i>(Consult factory for other fluids.)</i>
Elements	
Media:	Dimicron - 2µm, 20µm / Water Removal - 2µm, 20µm
Number required:	OLF-5, 5/15, and 5/4 = 1
Dirt Holding Capacity - ΔP = 36 psi (2.5 bar)	200g ISO MTD <i>(N5DM...)</i> / 185g ISO MTD <i>(N5AM...)</i>
Water Retention - ΔP = 36 psi (2.5 bar):	Approximately 0.5 quarts (0.5 liters)
Beta Ratio:	β <sub>x</sub> > 1000 <i>(absolute value)</i>
Maximum ΔP:	45 psi (3 bar)
Connections <i>(All Female)</i>	
OLF-5 with motor/pump:	Inlet & Outlet: 3/4 - 16UNF (SAE 8) (BSPP G1/2)
OLF-5/15 & 5/4:	Inlet & Outlet: 1 5/16-12UN (SAE 16) (BSPP G1)
OLF-5 without motor/pump:	Inlet: 9/16-18UNF (SAE 6) (BSPP G3/8) Outlet: 3/4-16UNF (SAE 8) (BSPP G1/2)
Weight	OLF-5-S = 15.5 lbs. (7.0 kg) OLF-5-E = 5.5 lbs. (2.5 kg) OLF-5/15 = 24.3 lbs. (11 kg) OLF-5/4 = 24.3 lbs. (11 kg)

Housing drain standard on all units

Black = SAE connections when using supplied adapters (standard)

Red = BSPP connections if supplied adapters are not used

## Model Code

**OLF-5 - S - 120 - K - N5DM002 - E / 12 / CD**

### Series

- OLF-5 = Series 5 (1.6 gpm)
- OLF-5/15 = Series 15 (4.9 gpm)
- OLF-5/4 = Series 15 (1.3 gpm)
- OLFCM-5/15 = With Fluid Condition Monitoring

### Pump Type

- S = Vane Pump\* (standard)
- E = Flow Control Valve (series 5 only)
- TV = Toploader with Motor (available for OLF-5/15 & OLFCM-5/15 only)

### Power Consumption

- 120 = 120W for all OLF 5
- 200 = 200W for all 24VDC
- 370 = 370W for all Series 5/15 & 5/4
- Z = Without motor-pump unit (series 5 only)

### Voltage

- K = 115V single phase
- M = 220V single phase
- N = 440V 3 phase
- T = 12VDC
- U = 24VDC
- Z = Without motor-pump unit

### Element

- N5DM002 = 2 micron
- N5DM005 = 5 micron
- N5DM010 = 10 micron
- N5DM020 = 20 micron
- N5AM002 = 2 micron with water removal
- N5AM020 = 20 micron with water removal

### Clogging Indicator

- E = Standard gauge (series 5 & 5/4 only)
- F = Static electrical switch VMF2F.0 (series 5 & 5/4 only)
- BM = Differential visual VM2BM.1 (series 5/15 & 5/4 only)
- C = Differential electrical VM2C.0 (series 5/15 & 5/4 only)
- D = Differential electrical/visual VM2D.0/L... (series 5/15 & 5/4 only)

### Mechanical Connections

- 12 = SAE Connections (standard)

### Supplementary Details

- L24, L48, L115, L230 = Lamp for D-type clogging indicator (LXX, XX = voltage)
- C = with ContaminationSensor CS 1310 (without display; OLFCM only)
- CD = with ContaminationSensor CS 1320 (with display; OLFCM only)
- AC = with ContaminationSensor CS 1310 and AquaSensor AS 1000 (without display; OLFCM only)
- ACD = with ContaminationSensor CS 1320 and AquaSensor AS 3000 (with display; OLFCM only)

Consult Factory for special options.

Not all combinations available.

\*Choose "S" for model without motor-pump and without flow control valve.

For replacement element part numbers, please see Section E - REPLACEMENT ELEMENTS of this catalog.

*Model Codes Containing RED are non-standard items – Minimum quantities and longer lead times may apply - Contact HYDAC for information and availability.*

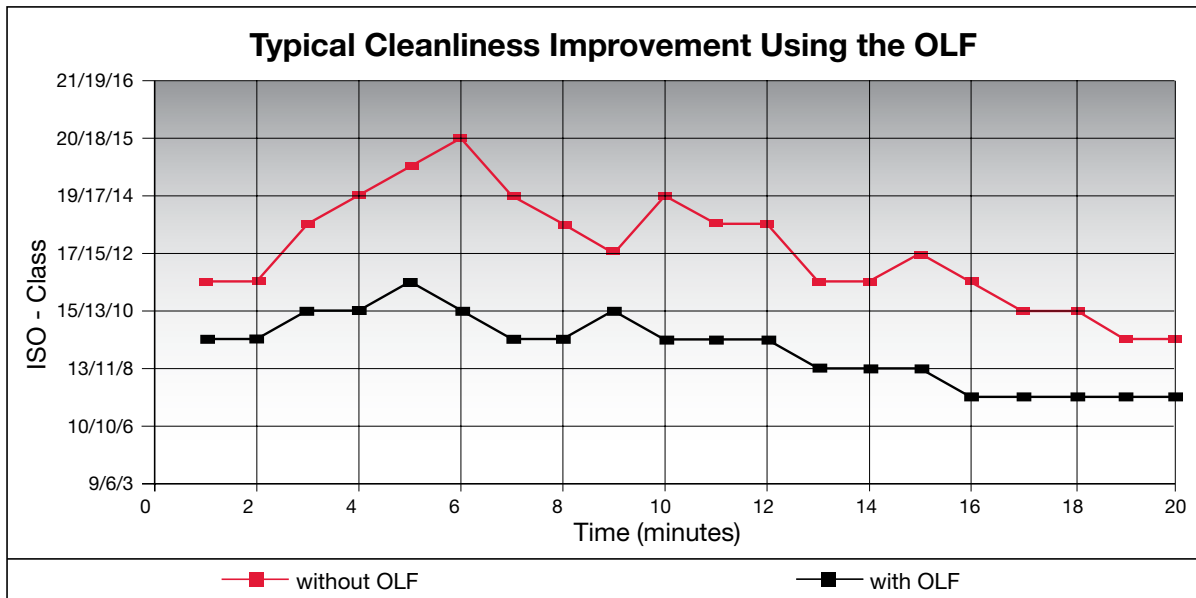

# OFFLINE FILTRATION SYSTEMS

## Dimensions

### OLF-5-S-...

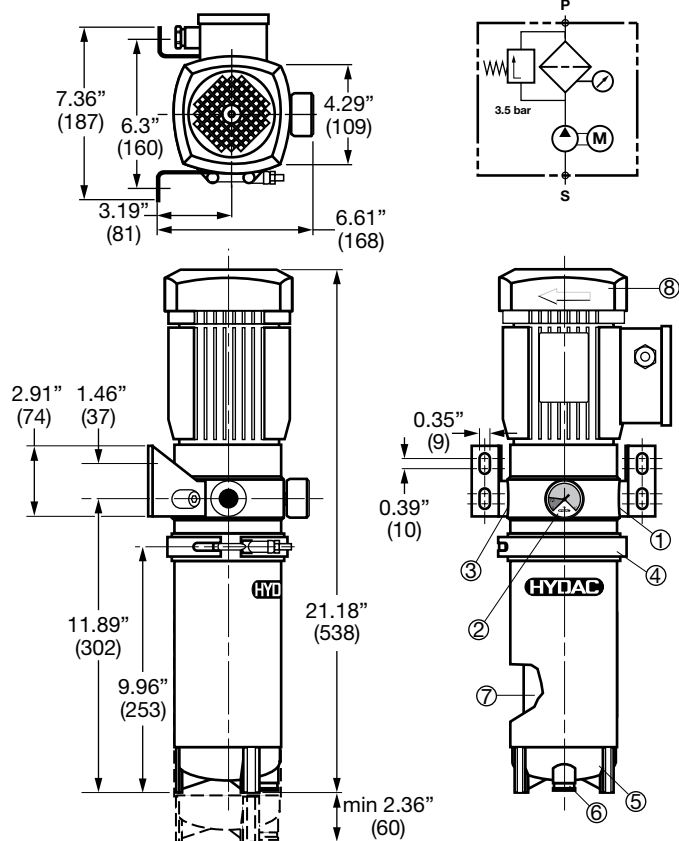

### OLF-5-E-...

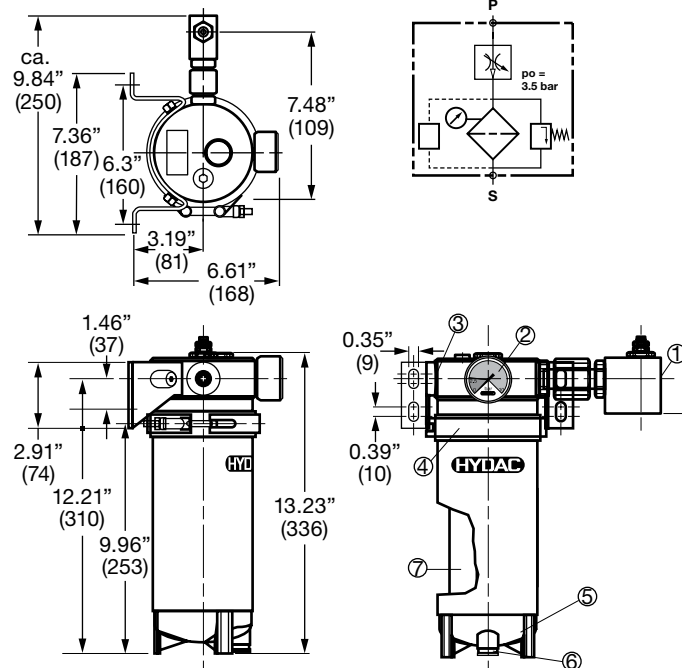

#### Key

- |                        |                    |
|------------------------|--------------------|
| 1 = Inlet              | 5 = Filter Bowl    |
| 2 = Clogging Indicator | 6 = Drain          |
| 3 = Outlet             | 7 = Filter Element |
| 4 = Clamp              | 8 = Electric Motor |

### OLF-5/4-S-... and OLF-5/15-S-...

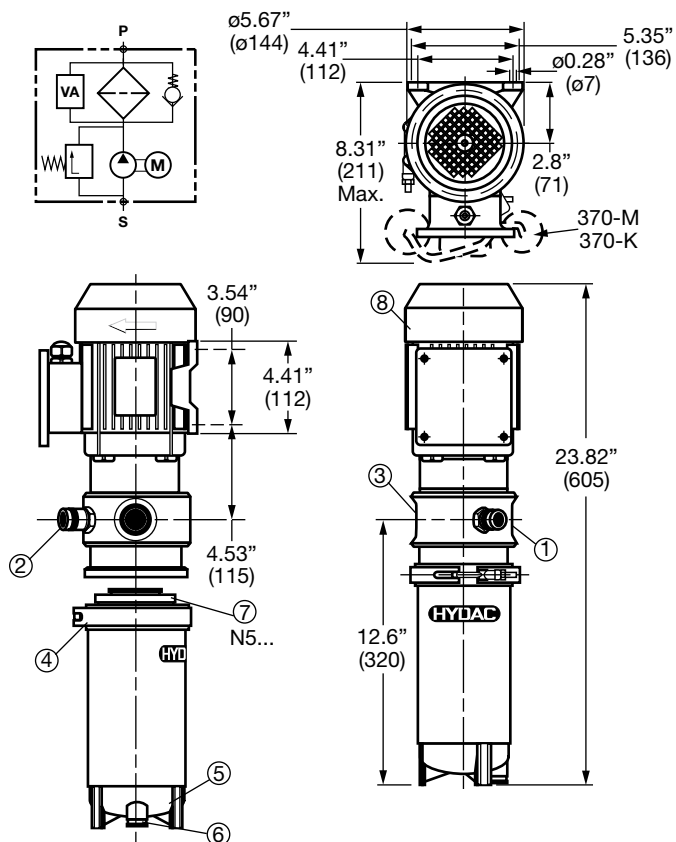

### OLF-5/4-SP-...

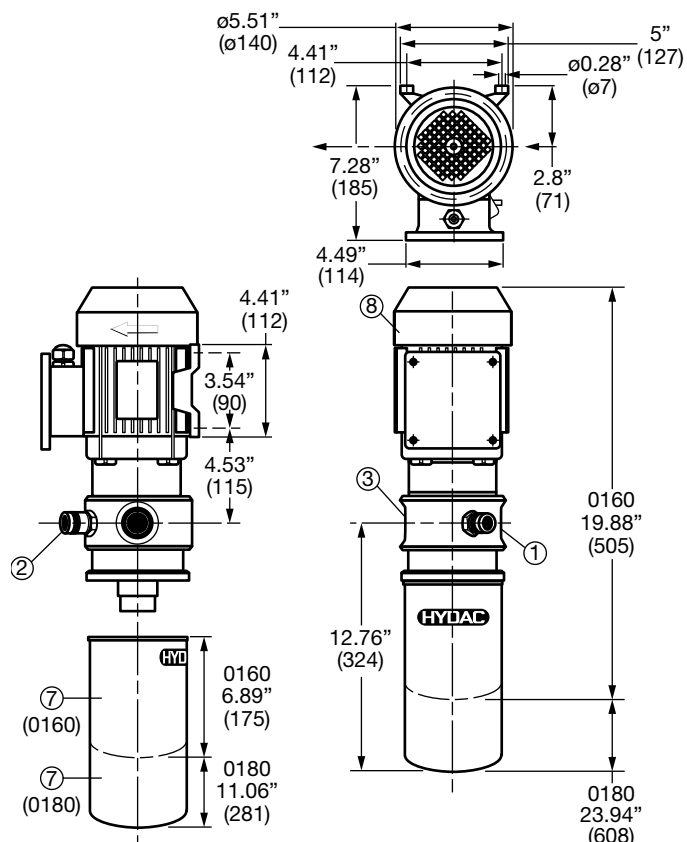

Dimensions are for general information only, all critical dimensions should be verified by requesting a certified print.

## Differential Pressure

**N5DM002**

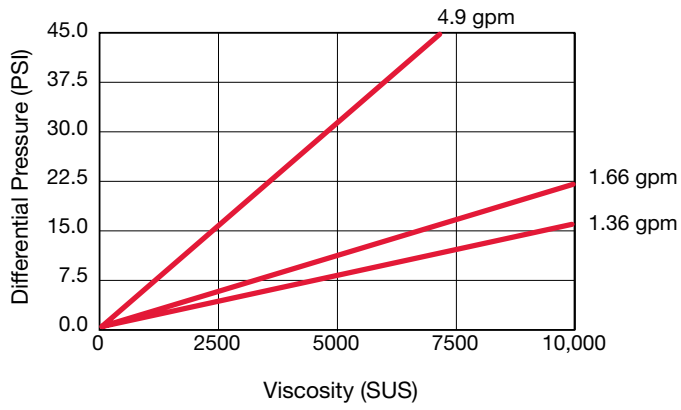

**N5DM020**

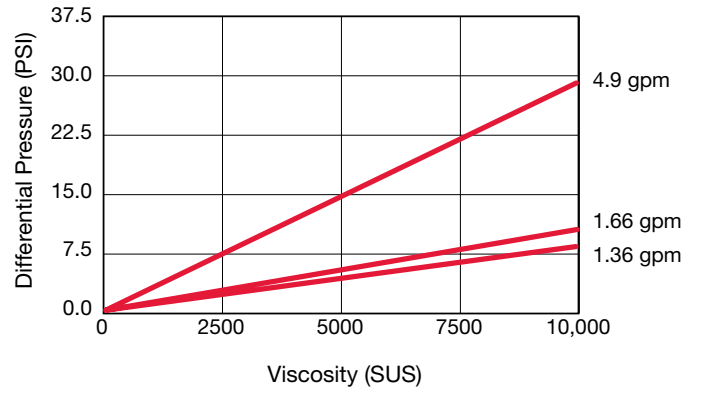

## SRV Flow Control Valve Curve



## Application

- Tank capacity to approx. 200 gallons
- Tank capacity to approx. 525 gallons

