

HIGH PRESSURE FILTERS

CF Series

Manifold Cartridge Filters
3000 psi • up to 25 gpm

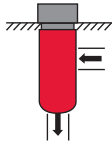

CFxx20



CFxx45

Hydraulic Symbol

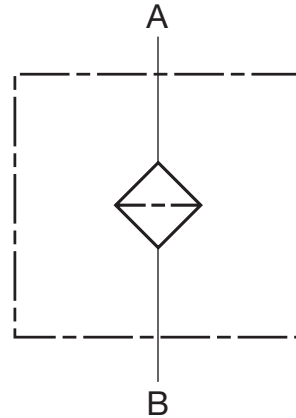

Features

- Made of aluminum for light weight and low cost.
- Made to dispose of when fully clogged.
- Low price - market competitive.

Technical Specifications

Port Connections	CF20	SAE-16 Modified Cavity
	CF45	SAE-20 Cavity (VC20-S3)
Direction of Flow	Outside to Inside flow	
Materials of Construction	Aluminum	
Flow Capacity		
CF20	5 GPM (15 micron - fiberglass media) 2.5 GPM recommended design flow max. - for high efficiency media	
CF45	12 GPM (25, 149 micron - wire screen media) 12 GPM (15 micron - fiberglass media) 6 GPM recommended design flow max. - for high efficiency media 25 GPM (25, 149 micron - wire screen media)	
Housing Pressure Rating		
Max. Allowable Working Pressure:	3000 psi (207 bar)	
Proof Pressure:	4500 psi (310 bar)	
Element Performance Rating		
MM, W	290 psid (20 bar)	
Fluid Temperature Range		
	-22°F to 250°F (-30°C to 121°C) Consult HYDAC for applications operating below -22°F (-30°C)	
Fluid Compatibility		
Compatible with all hydrocarbon based, synthetic, water glycol, oil/water emulsion, and high water based fluids when the appropriate seals are selected.		

Applications



Agricultural



Construction



Industrial



Commercial
Municipal



Railways

Model Code

CF W 20 G 25 W 1 . 0 / 12

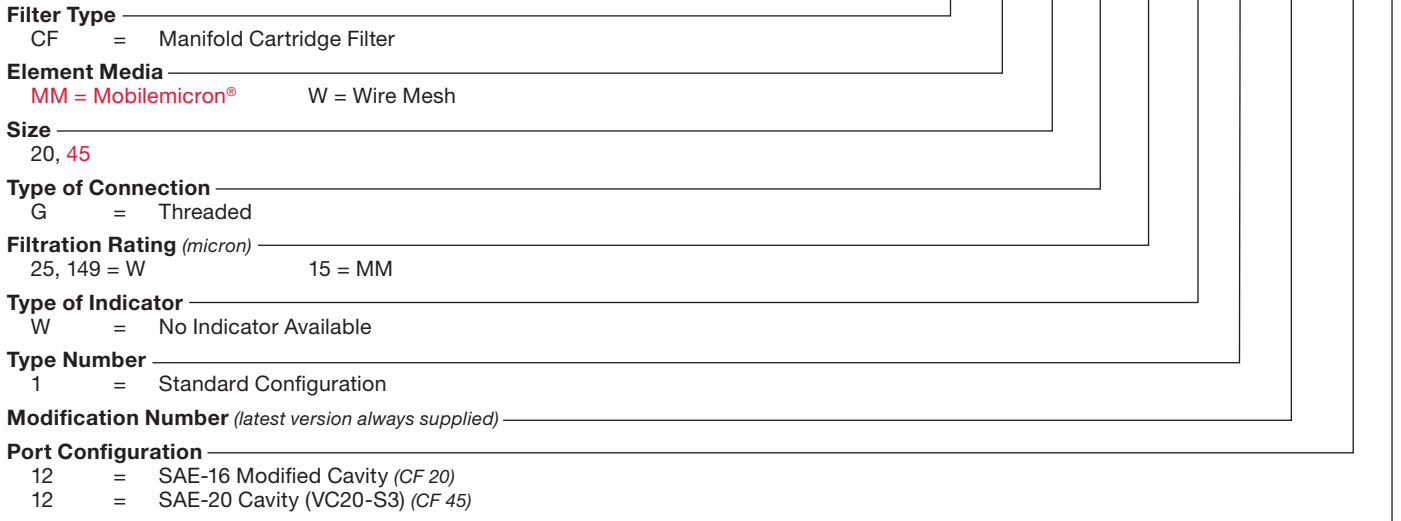

Model Codes Containing RED are non-stock items — Minimum quantities may apply — Contact HYDAC for information and availability

Pressure Drop Curves

CFMM20G15W1.0/12

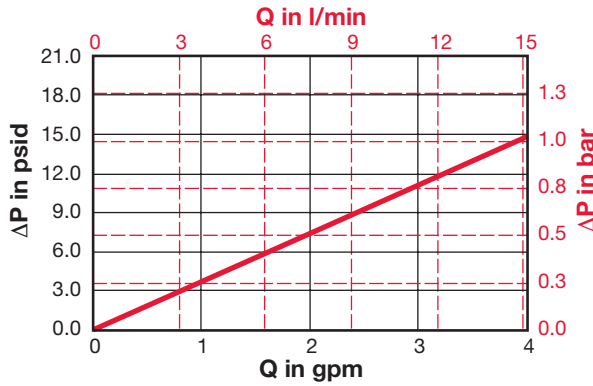

CFW20G25/149W1.0/12

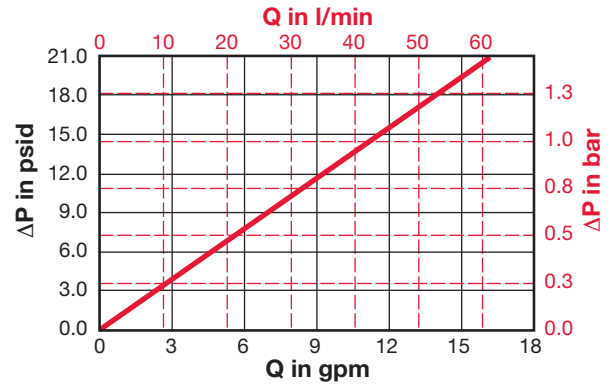

CFMM45G15W1.0/12

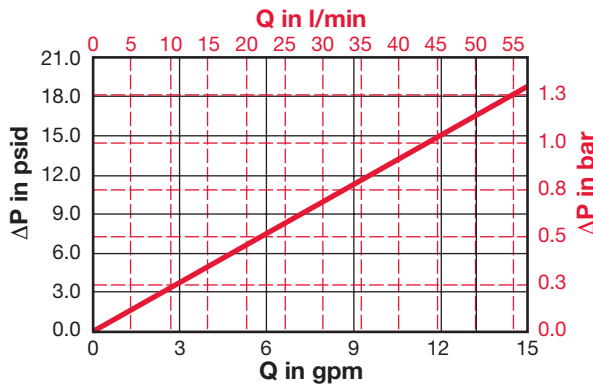

CFW45G25/149W1.0/12

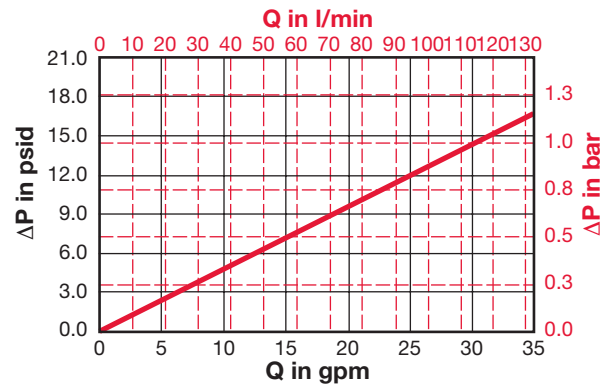

HIGH PRESSURE FILTERS

Dimensions
CFxx20

Installation Torque:
CF20 – 60 Lbf-ft (80 N-m)

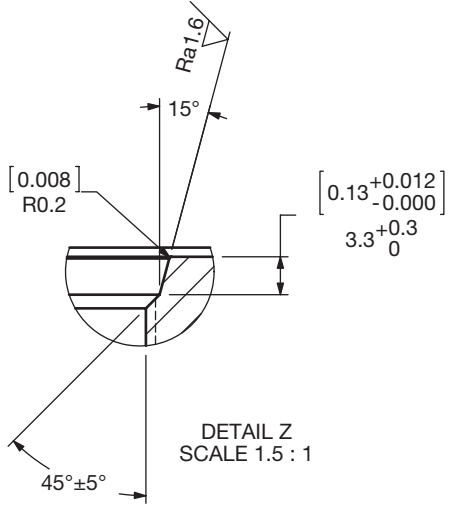
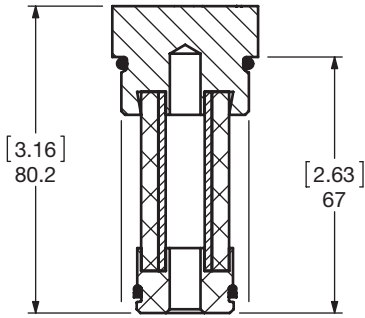
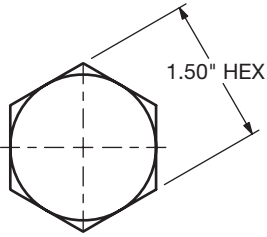

Ø 1-5/16-12UN-2A IN.

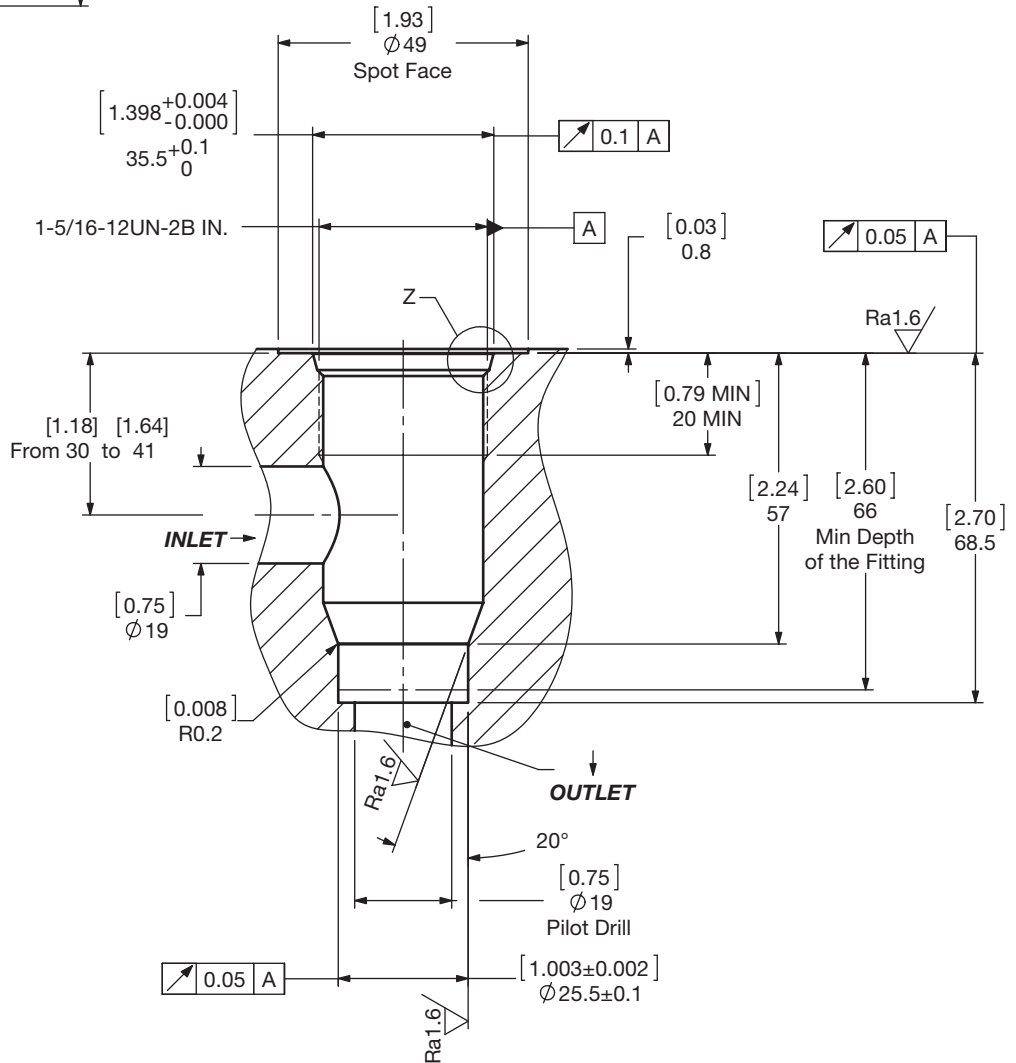

Size	20
Weight (lbs.)	0.5

Dimensions shown are [inches] millimeters for general information and overall envelope size only. Weights listed include element.
For complete dimensions please contact HYDAC to request a certified print.

Dimensions CFxx45

Installation Torque:
CF45 – 90 Lbf-ft (120 N-m)

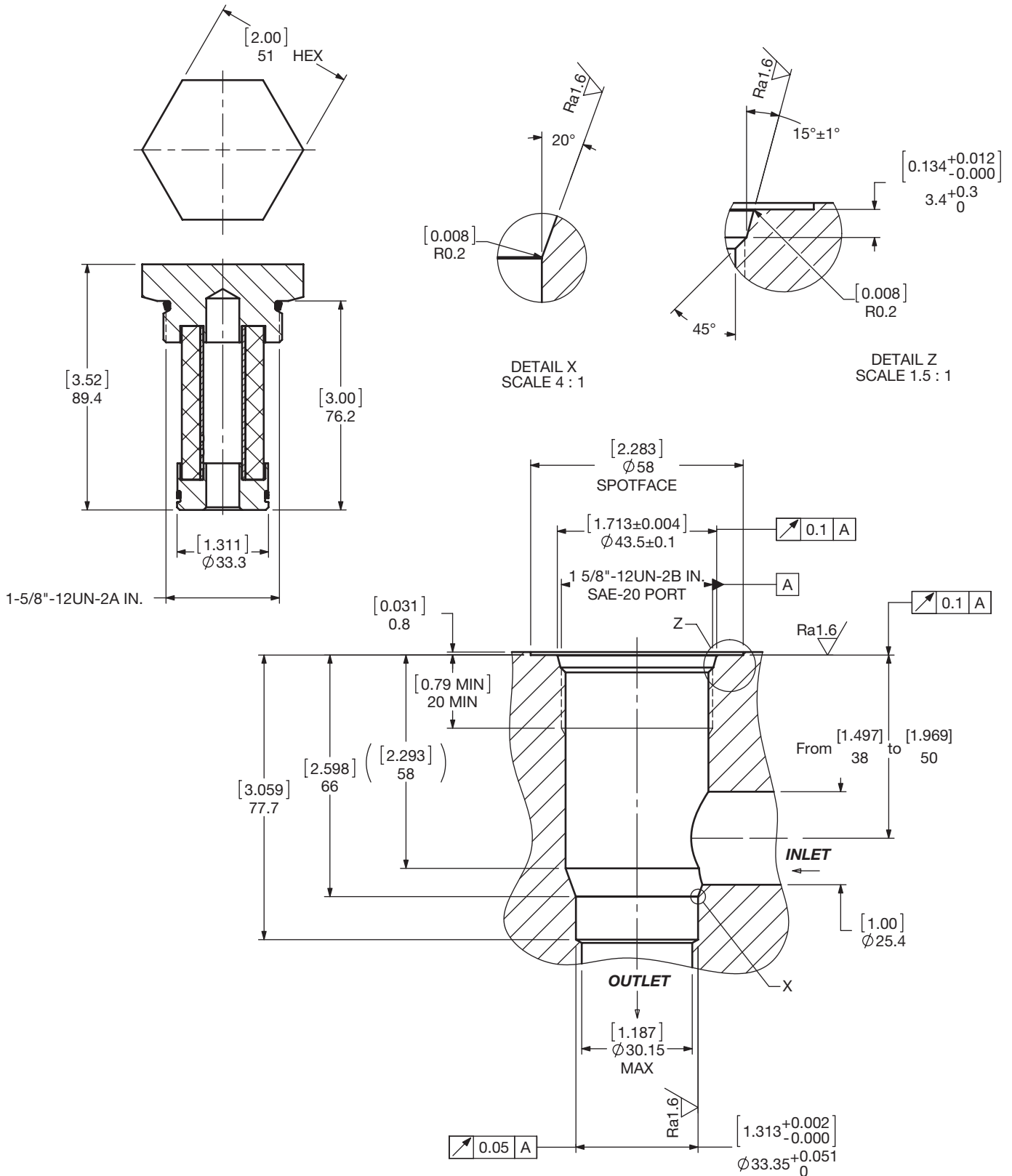

Size	45
Weight (lbs.)	0.5

Dimensions shown are [inches] millimeters for general information and overall envelope size only. Weights listed include element. For complete dimensions please contact HYDAC to request a certified print.