

LOW PRESSURE FILTERS

RFLD Cast Series

Inline Duplex Filters

580 psi • up to 340 gpm

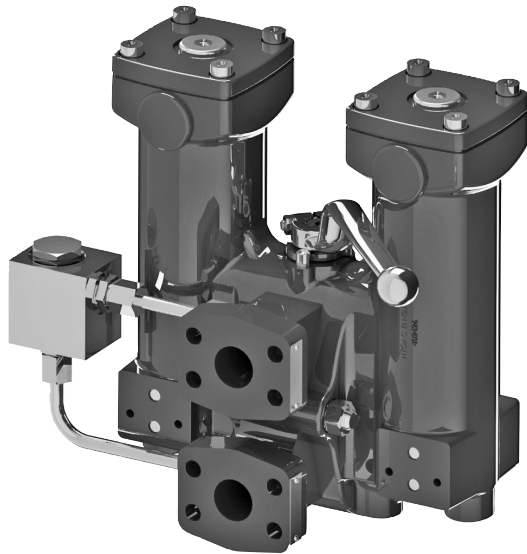

Features

- Inlet and outlet connections are located on the same side of the transfer valve. Inlet on top and the outlet on bottom.
- Transfer valve and pressure equalization line allows easy changeover between filter housings without costly system shutdown. (standard with 851, 951 & 1301)
- Clogging indicators have no external dynamic seal. High reliability is achieved and magnetic actuation eliminates a leak point.

Note: This filter is configured with anR.... type (return/low pressure) element, so if the filter requires a bypass, the bypass is located in the closed end cap of the cartridge element.

Hydraulic Symbol

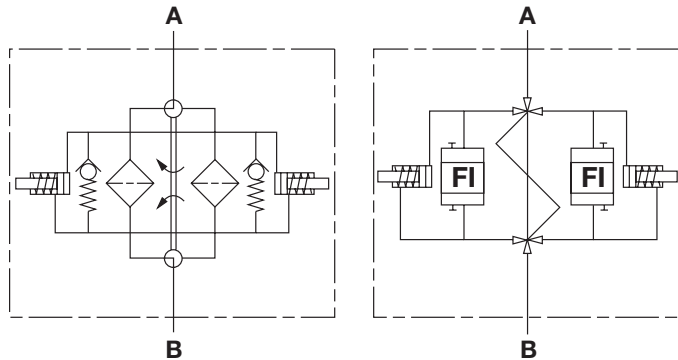

Technical Specifications

Mounting Method	Mounting holes on opposite side from Inlet/Outlet port faces	
Port Connection	Flange ports with metric threads	
111	1" SAE DN 25 Code 61	
241	1 1/2" SAE DN 38 Code 61	
331	1 1/2" SAE DN 38 Code 61, 2" SAE DN 51 Code 61	
501	1 1/2" SAE DN 38 Code 61, 2" SAE DN 51 Code 61	
661	2" SAE DN 51 Code 61, 2 1/2" SAE DN 64 Code 61	
851	2" SAE DN 51 Code 61, 2 1/2" SAE DN 64 Code 61	
951	3" SAE/DIN DN 76 Code 61	
1301	3" SAE/DIN DN 76 Code 61, 4" SAE/DIN DN 102 Code 61	
Flow Direction	Inlet: Front Top	Outlet: Front Bottom
Construction Materials		
Head, Lid, Elbow	Ductile iron	
Flow Capacity		
111	29 gpm (110 lpm)	
241	63 gpm (240 lpm)	
331	87 gpm (330 lpm)	
501	132 gpm (500 lpm)	
661	174 gpm (660 lpm)	
851	225 gpm (850 lpm)	
951	251 gpm (950 lpm)	
1301	343 gpm (1300 lpm)	
Housing Press. Rating	111 - 241	501 - 1301
Max. Allowable Working Pressure	580 psi (40 bar)	360 psi (25 bar)
Fatigue Pressure	580 psi (40 bar)	360 psi (25 bar)
Burst Pressure	>2320 psi (160 bar)	>1440 psi (100 bar)
Element Collapse Pressure Rating		
ON, W/HC	290 psid (20 bar)	
ECON2, BN4AM, AM, P/HC	145 psid (10 bar)	
Fluid Temp. Range	14°F to 212°F (-10°C to 100°C)	
Consult HYDAC for applications below 14°F (-10°C)		
Fluid Compatibility		
Compatible with all hydrocarbon based, synthetic, water glycol, oil/water emulsion, and high water based fluids when the appropriate seals are selected.		
Indicator Trip Pressure		
ΔP = 29 psid (2 bar) -10% (standard)		
ΔP = 72 psid (5 bar) -10%		
Bypass Valve Cracking Pressure		
ΔP = 43 psid (3 bar) +10% (standard)		
ΔP = 87 psid (6 bar) +10%		

Applications



Automotive



Gearboxes



Industrial



Power Generation



Pulp & Paper



Railways



Shipbuilding



Steel / Heavy Industry

Model Code

RFLD ON 1301 D A T 10 D 1 . X / V

Filter Type _____
 RFLD = Duplex Inline Filter

Element Media _____
 ON = Optimicron® XSX = Stat-X®
 BN/AM = Betamicron®/Aquamicron®
 ECON2 = ECOmicron® AM = Aquamicron®
 W/HC = Wire Mesh P/HC = Polyester

Sizes _____
 111, 241, 331, 501, 661, 851, 951, 1301

Operating Pressure _____
 D = 25 bar (sizes 331, 501, 661, 851, 951, 1301)
 E = 40 bar (sizes 111, 241)

Type of Change-over _____
 A = ball type change-over valve

Type of Connection / Connection Sizes _____
 I = 1" SAE DN 25 Code 61 (size 111 only) M = 2 1/2" SAE DN 64 Code 61 (sizes 661, 851)
 K = 1 1/2" SAE DN 38 Code 61 (sizes 241, 331, 501) S = 3" SAE/DIN DN 76 Code 61 (sizes 661, 851, 951, 1301)
 L = 2" SAE DN 51 Code 61 (sizes 331, 501, 661, 851) T = 4" SAE/DIN DN 102 Code 61 (sizes 951, 1301)

Filtration Rating (microns) _____
 1, 3, 5, 10, 15, 20 = ON 3, 5, 10, 20 = XSX 3, 10 = BN4AM
 40 = AM 25, 50, 100, 200 = W/HC 10, 20 = P/HC 3, 5, 10, 20 = ECON2

Type of ΔP Clogging Indicator _____
 A, B, BM, C, D (Others available upon request, see Clogging Indicators section.)

Type Code _____
 1

Modification Number (latest version always supplied) _____

Seals _____
 (omit) = Nitrile rubber (NBR) (standard) V = Fluorocarbon elastomer (FKM) EPR = Ethylene propylene rubber (EPR)

Bypass Valve _____
 (omit) = 43 psid (3 bar) (standard)
 B1 = 14.5 psid (1 bar) (tube or coolant)
 B6 = 87 psid (6 bar) (return line extended life)
 KB = no bypass (flushing systems)] not available with ECON2

Supplementary Details _____
 SO263 = Modification of elements for Skydrol or HYJET phosphate ester fluids
 L24, L48, L110, L220 = Lamp for D-type clogging indicator (LXX, XX = voltage)
 cRUus = Electrical Indicator with underwriter's approval
 DE = Dual Indicator Option (one indicator per duplex side)
 SB = Pressure equalization line (sizes 111 - 661; included standard on larger sizes)
 SFREE = Element specially designed to minimize electrostatic charge generation
 SO376 = Modification of ON and W/HC elements for HFA, HFB, HFC, and HFD flame retardant liquids

Replacement Element Model Code

0110 R 010 ON / V B6

Size _____
 0110, 0240, 0330, 0500,
 0660, 0850, 0950, 1300

Filtration Rating (micron) _____
 1, 3, 5, 10, 15, 20 = ON
 3, 5, 10, 20 = XSX 3, 10 = BN4AM
 3, 5, 10, 20 = ECON2 40 = AM
 25, 50, 100, 200 = W/HC 10, 20 = P/HC

Element Media _____
 ON, XSX, BN4AM, ECON2, AM, W/HC, P/HC

Seals _____
 (omit) = Nitrile rubber (NBR) (standard)
 V = Fluorocarbon elastomer (FKM)
 EPR = Ethylene propylene rubber (EPR)

Bypass Valve _____
 (omit) = 43 psid (3 bar) (standard)
 B1 = 14.5 psid (1 bar)
 B6 = 87 psid (6 bar)
 KB = No Bypass

Supplementary Details _____
 SO263 = (same as above)
 SFREE = (same as above)
 SO376 = (same as above)

Clogging Indicator Model Code

VM 2 B . X / V

Indicator Prefix _____
 VM = G 1/2 3000 psi

Trip Pressure _____
 2 = 29 psid (2 bar) (standard)
 5 = 72 psid (5 bar) (optional)

Type of Indicator _____
 A = No indicator, plugged port
 B = Pop-up indicator (auto reset)
 BM = Pop-up indicator (manual reset)
 C = electric switch - SPDT
 D = electric switch & LED light - SPDT

Modification Number _____

Supplementary Details _____

Seals _____
 (omit) = Nitrile (NBR) (standard)
 V = Fluorocarbon elastomer (FKM)
 EPR = Ethylene propylene rubber (EPR)

Light Voltage (D type indicators only) _____
 L24 = 24V L110 = 110V

Thermal Lockout (VM type C, D, J, J4 only) _____
 T100 = Lockout below 100°F

Underwriter's Approval (VM type C, D, J, J4 only) _____
 cRUus = Electrical Indicator with underwriter's approval

(For additional details and options, see Clogging Indicators section.)

Model Codes Containing RED are non-stock items — Minimum quantities may apply — Contact HYDAC for information and availability

LOW PRESSURE FILTERS

Dimensions

RFLD 111 - 1301

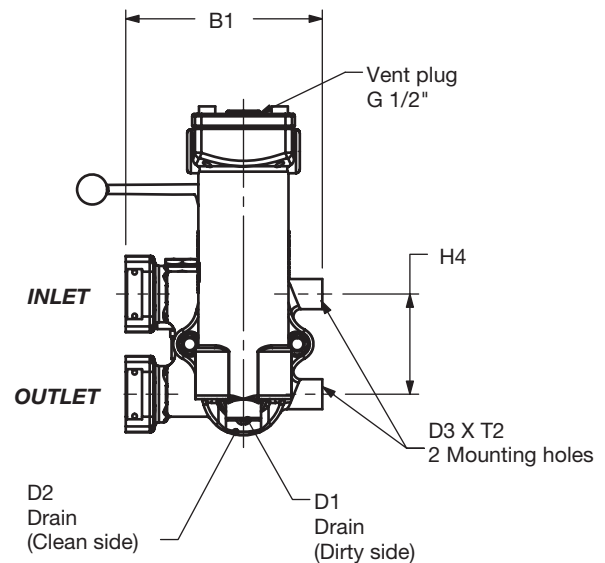
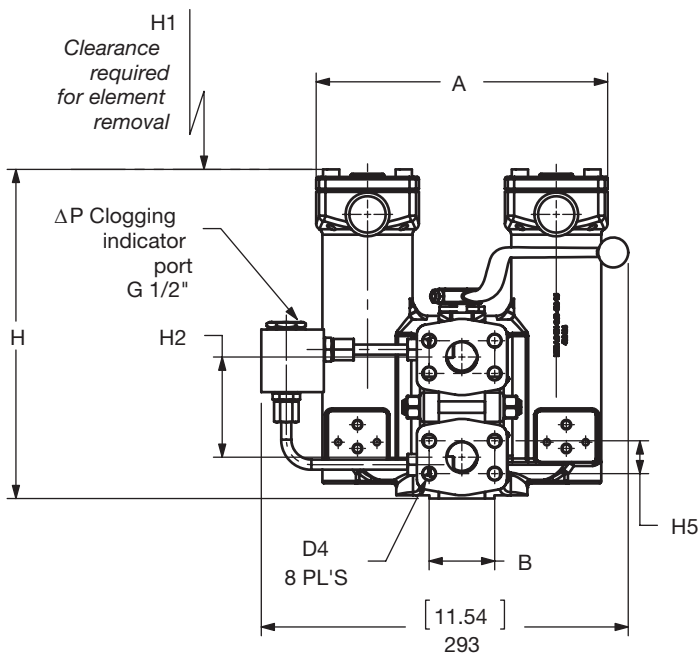
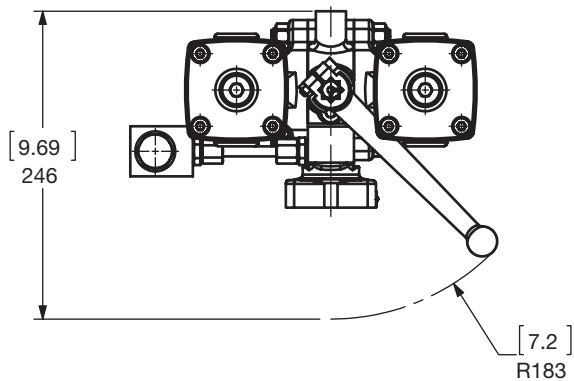

Size	A	B	B1	H	H1	H2	H4	H5	D1	D2	D3	D4	T2	Wt. (lbs)
RFLD 111 EAI (DN 25)	[9.17] 233	[2.06] 52.4	[6.18] 157	[10.35] 263	[6.89] 175	[3.15] 80	[3.15] 80	[1.03] 26.2	G 1/4	G 1/4	M12	M10	[0.98] 25	37.4
RFLD 241 EAK (DN 40)	[11.89] 302	[2.75] 69.8	[6.57] 167	[12.28] 312	[8.27] 210	[3.74] 95	[5.51] 140	[1.41] 35.7	G 1/4	G 1/4	M12	M12	[0.71] 18	59.4
RFLD 331 DAL (DN 50)	[14.96] 380	[3.06] 77.8	[7.36] 187	[12.72] 323	[7.87] 200	[4.33] 110	[6.50] 165	[1.69] 42.9	G 1/2	G 1/4	M12	M12	[0.71] 18	81.4
RFLD 501 DAL (DN 50)	[14.96] 380	[3.06] 77.8	[7.36] 187	[15.75] 400	[11.02] 280	[4.33] 110	[6.50] 165	[1.69] 42.9	G 1/2	G 1/4	M12	M12	[0.71] 18	85.8
RFLD 661 DAM (DN 65)	[19.52] 496	[3.50] 88.9	[9.92] 252	[18.58] 472	[13.39] 340	[4.33] 110	[6.50] 165	[2.00] 50.8	G 1/2	G 1/4	M12	M12	[0.71] 18	162.8
RFLD 851 DAS (DN 80)	[19.52] 496	[4.19] 106.4	[8.74] 222	[25.59] 650	[16.54] 420	[9.06] 230	[9.06] 230	[2.44] 61.9	G 1/2	G 1/4	M12	M16	[0.91] 23	193.6
RFLD 951 DAS (DN 80)	[21.57] 548	[4.19] 106.4	[8.74] 222	[23.43] 595	[14.57] 370	[9.06] 230	[9.06] 230	[2.44] 61.9	G 1/2	G 1/4	M12	M16	[0.91] 23	231
RFLD 1301 DAT (DN 100)	[21.85] 555	[5.13] 130.2	[9.76] 248	[29.37] 746	[19.29] 490	[9.84] 250	[9.84] 250	[3.06] 77.8	G 1/2	G 1/4	M16	M16	[0.91] 23	275

Dimensions shown are [inches] millimeters for general information and overall envelope size only. Weights listed include element.
For complete dimensions please contact HYDAC to request a certified print.

Sizing Information

Total pressure loss through the filter is as follows:

$$\text{Assembly } \Delta P = \text{Housing } \Delta P + \text{Element } \Delta P$$

Housing Curve:

Pressure loss through housing is as follows:

$$\text{Housing } \Delta P = \text{Housing Curve } \Delta P \times \frac{\text{Actual Specific Gravity}}{0.86}$$

Adjustments must be made for viscosity & specific gravity of the fluid to be used! (see "Sizing HYDAC Filter Assemblies" in Section B - Overview)

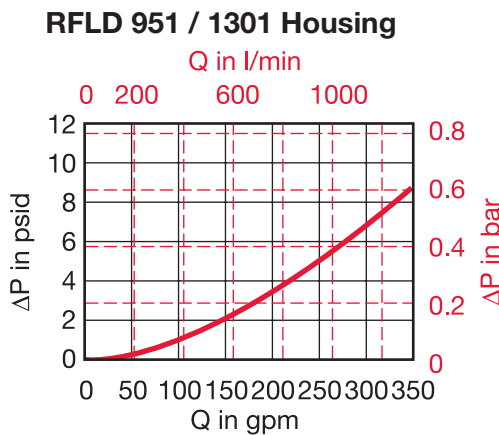
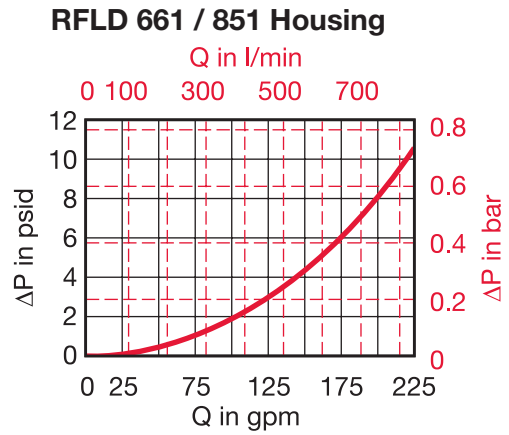
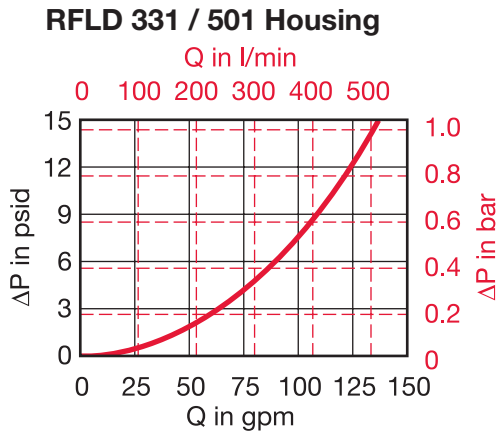
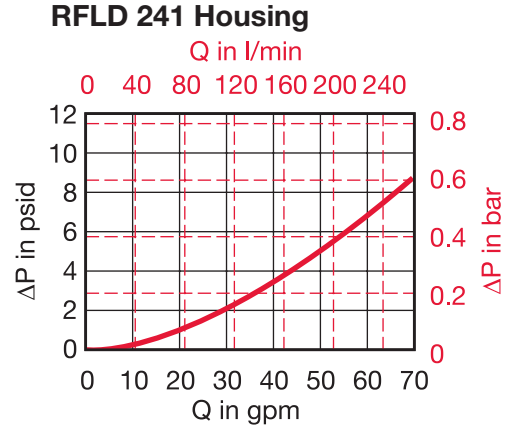
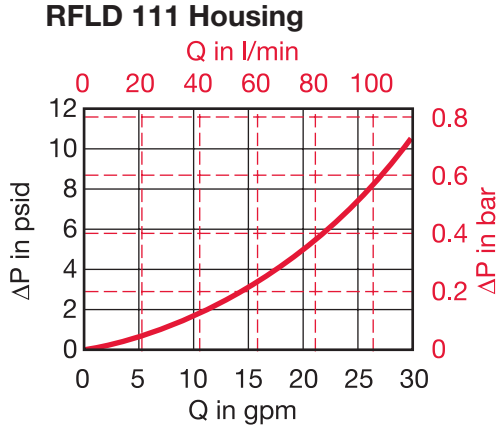

LOW PRESSURE FILTERS

Required Element Per Housing

Housing Size	Element Size	Elements per Side
111	0110	1
241	0240	1
331	0330	1
501	0500	1
661	0660	1
851	0850	1
951	0950	1
1301	1300	1

Element K Factors

$$\Delta P \text{ Elements} = \text{Elements (K) Flow Factor} \times \text{Flow Rate (gpm)} \times \frac{\text{Actual Viscosity (SUS)} \times \text{Actual Specific Gravity}}{141 \text{ SUS} \quad 0.86}$$

(From Tables Below)

Optimicron Size	...R...ON					
	1 µm	3 µm	5 µm	10 µm	15 µm	20 µm
0110 R XXX ON	1.224	0.719	0.487	0.296	0.234	0.178
0240 R XXX ON	0.571	0.284	0.201	0.125	0.101	0.077
0330 R XXX ON	0.444	0.204	0.15	0.081	0.07	0.056
0500 R XXX ON	0.289	0.143	0.104	0.06	0.046	0.038
0660 R XXX ON	0.196	0.093	0.066	0.037	0.031	0.025
0850 R XXX ON	0.152	0.072	0.055	0.032	0.024	0.02
0950 R XXX ON	0.131	0.057	0.043	0.026	0.021	0.017
1300 R XXX ON	0.094	0.04	0.032	0.019	0.018	0.012

Stat-X Size	...R...X SX			
	3 µm	5 µm	10 µm	20 µm
0110 R XXX X SX	0.719	0.487	0.296	0.178
0240 R XXX X SX	0.284	0.201	0.125	0.077
0330 R XXX X SX	0.204	0.15	0.081	0.056
0500 R XXX X SX	0.143	0.104	0.06	0.038
0660 R XXX X SX	0.093	0.066	0.037	0.025
0850 R XXX X SX	0.072	0.055	0.032	0.02
0950 R XXX X SX	0.057	0.043	0.026	0.017
1300 R XXX X SX	0.04	0.032	0.019	0.012

ECOMICRON Size	...R...ECON2			
	3 µm	5 µm	10 µm	20 µm
0240 R XXX ECON2	0.340	0.209	0.143	0.099
0330 R XXX ECON2	0.230	0.148	0.093	0.066
0500 R XXX ECON2	0.165	0.104	0.071	0.044
0660 R XXX ECON2	0.104	0.066	0.044	0.027
0850 R XXX ECON2	0.082	0.055	0.038	0.022
0950 R XXX ECON2	0.066	0.044	0.027	0.022
1300 R XXX ECON2	0.044	0.033	0.022	0.016

Betamicron/Aquamicon Size	...R...BN4AM	
	3 µm	10 µm
0330 R XXX BN4AM	0.477	0.165
0500 R XXX BN4AM	0.313	0.11
0660 R XXX BN4AM	0.192	0.066
0850 R XXX BN4AM	0.154	0.049
0950 R XXX BN4AM	0.132	0.044
1300 R XXX BN4AM	0.088	0.033

Aquamicon Size	...R...AM
	40 µm
0330 R 040 AM	0.115
0500 R 040 AM	0.076
0660 R 040 AM	0.051
0850 R 040 AM	0.040
0950 R 040 AM	0.036
1300 R 040 AM	0.026

All Element K Factors in psi / gpm.

