

HYDAC KineSys Variable speed drive DVA-Kit

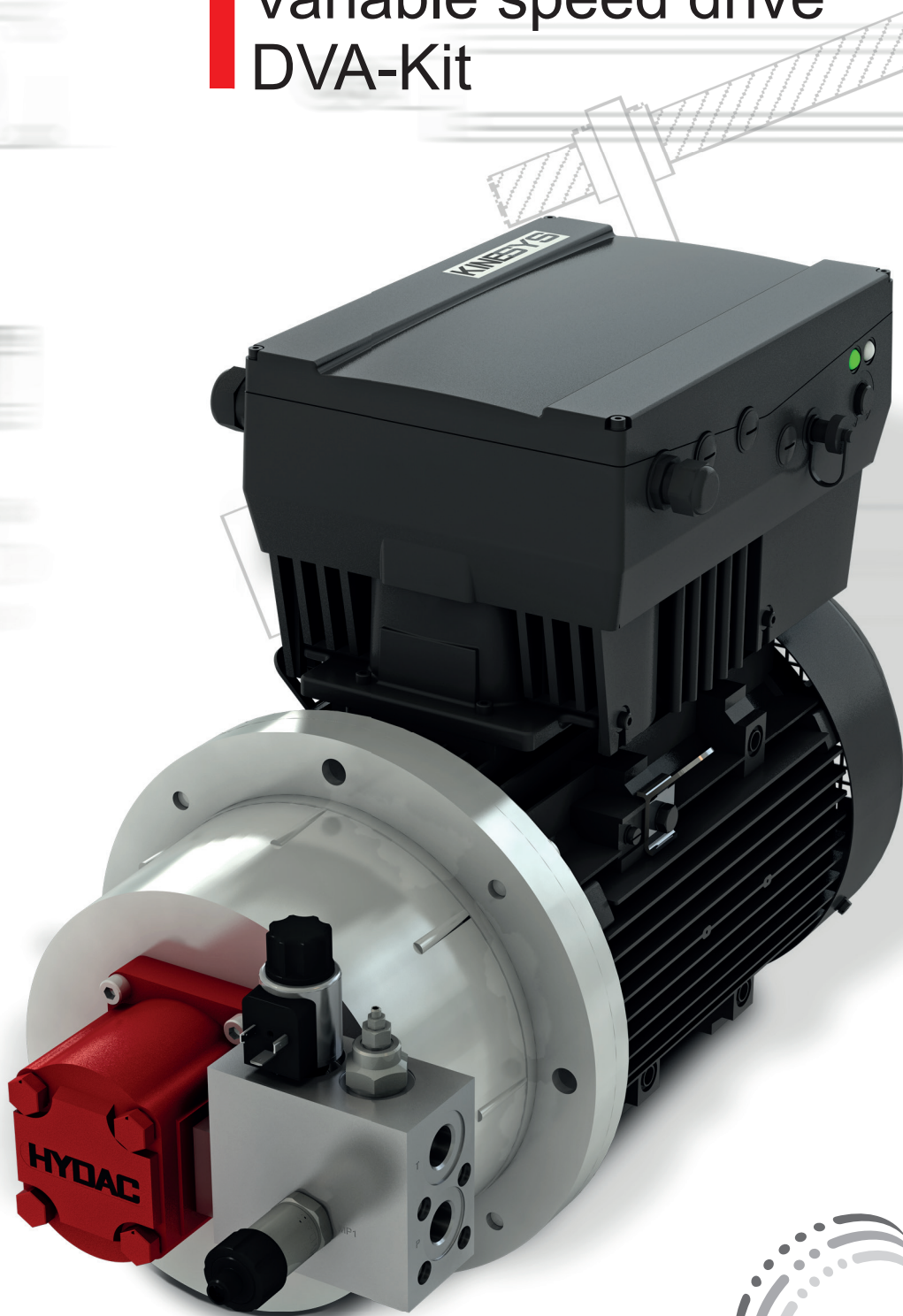

KINESYS

Note

The information in this brochure relates to the operating conditions and applications described.

For applications and operating conditions not described, please contact the relevant technical department.

Subject to technical modifications.



HYDAC was founded in 1963 in Sulzbach/Neuweiler in Germany, which is still the company's head office today. With over 8,000 employees worldwide, HYDAC is one of the leading companies for fluid power, hydraulics and electronics.

With the breadth and depth of its product range and with its recognized skills in development, manufacturing, sales and service, HYDAC designs and makes modern and reliable drive systems.

With over 45 subsidiaries outside of Germany and more than 500 sales and service partners, HYDAC is close by its worldwide customers and is a reliable, local partner.

HYDAC KineSys stands for kinematic systems which excel through their perfect symbiosis of hydraulic and electromechanical engineering.

Customers increasingly require modern machines and systems which offer higher productivity while at the same time using resources more efficiently. Against a background of constantly increasing costs for energy and for raw materials, the efficient design of the drive system is an important component in the overall life cycle cost. This means that modern drive technology represents a competitive advantage.

Using the experience gained from many international projects, our industry and product specialists will analyze your application. Together we develop quick and effective economical solutions.

Depending on the application, different strategies are selected for the drive tasks, from a simple control right up to highly dynamic controls. We can make use of numerous test benches and simulation systems. It is of no consequence whether it concerns the custom development and manufacture of stationary or mobile systems or the implementation of series solutions.

With access to the entire range of HYDAC products we can provide you with the best solution for your requirements. This reduces complexity and ensures the best, efficient function for the operation of your machine and system.

Providing you with the best solution is our challenge.



Table of Content

1	Function and characteristics.....	3
2	Description.....	4
2.1	The assembly	4
2.2	Additional options	5
2.3	Mounting examples	6
2.4	Function modules	7
2.4.1	Function module with block function 1.....	7
2.4.2	Function module with block function 2.....	7
2.4.3	Accumulator charging block	8
2.4.4	Function module with block function 4.....	8
3	Technical data	9
3.1	Model code	9
3.2	Pressure and flow rate setting ranges.....	10
3.3	Electrical specifications	12
3.4	Operating mode	12
3.5	Operating fluid	12
4	Dimensions	13
4.1	DVA-Kits	13
4.2	Function module 45 block function 1 - 2 - 4	14
4.3	Function module 100 block function 1 - 2 - 4	14
4.4	Accumulator charging block	15
5	Application examples.....	16
5.1	Setting flow rate	16
5.2	Pressure/flow rate/position/temperature regulation.....	16
5.3	Block functions.....	17
5.4	Pressure-regulated operation with accumulator charge control	18
5.5	Operating range via nominal flow rate (field weakening operation)	19
6	Planning as interactive process.....	20

Product information

1 Function and characteristics

The DVA-Kit is a compact variable speed drive (VSD) for hydraulic applications, which is characterized by a perfect symbiosis between hydraulics and electro mechanics.

The pre-configured system comprises a standard electric motor with an attached frequency inverter coupled to an external gear pump. To complete the system, a connection block with pump protection and optional accumulator is added. The electrical connection is effected directly on the frequency inverter.

Power dissipation can be reduced to a minimum by adapting the KineSys solution to the conditions.

The drive system is fully parameterized and coordinated in the frequency inverter for the various fields of application.

The pressure and flow rate can be supplied in line with demand via the internal control system.

The basic hydraulic control system is realized via a function module, which is flanged directly to the pump.

KineSys motor-pump units are a user-friendly and energy-efficient solution for use in small to medium-sized constant pressure systems.

Product features, DVA-Kit, standard program

- Drive power up to 22 kW
- Operating pressure up to 210 bar
- Flow rates up to 100 l/min
- Integrated regulation of pressure or flow rate
- Logic functions can be realized
- 4 digital / 2 analogue inputs (pressure-flow rate sensor can be connected)
- 2 digital / 1 analogue output
- No switch cabinet needed
- Input voltage: 3~ 200 V - 480 V, 47 - 63 Hz
- IP55
- **Differing technical data possible upon request (such as higher pressures and flow rates, IP65)**

Product advantages

- Continuous operation with constant pressure possible for specific applications
- Variable speed accumulator charging can be integrated, with switch-off function
- Variable pressure and flow level
- Various control algorithms can be integrated
- Electrical connection only via frequency inverter (independent of phase rotation)

Delivery

The DVA-Kit is fully assembled and inspected before delivery, with customer-specific parameters preset.

2 Description

2.1 The assembly

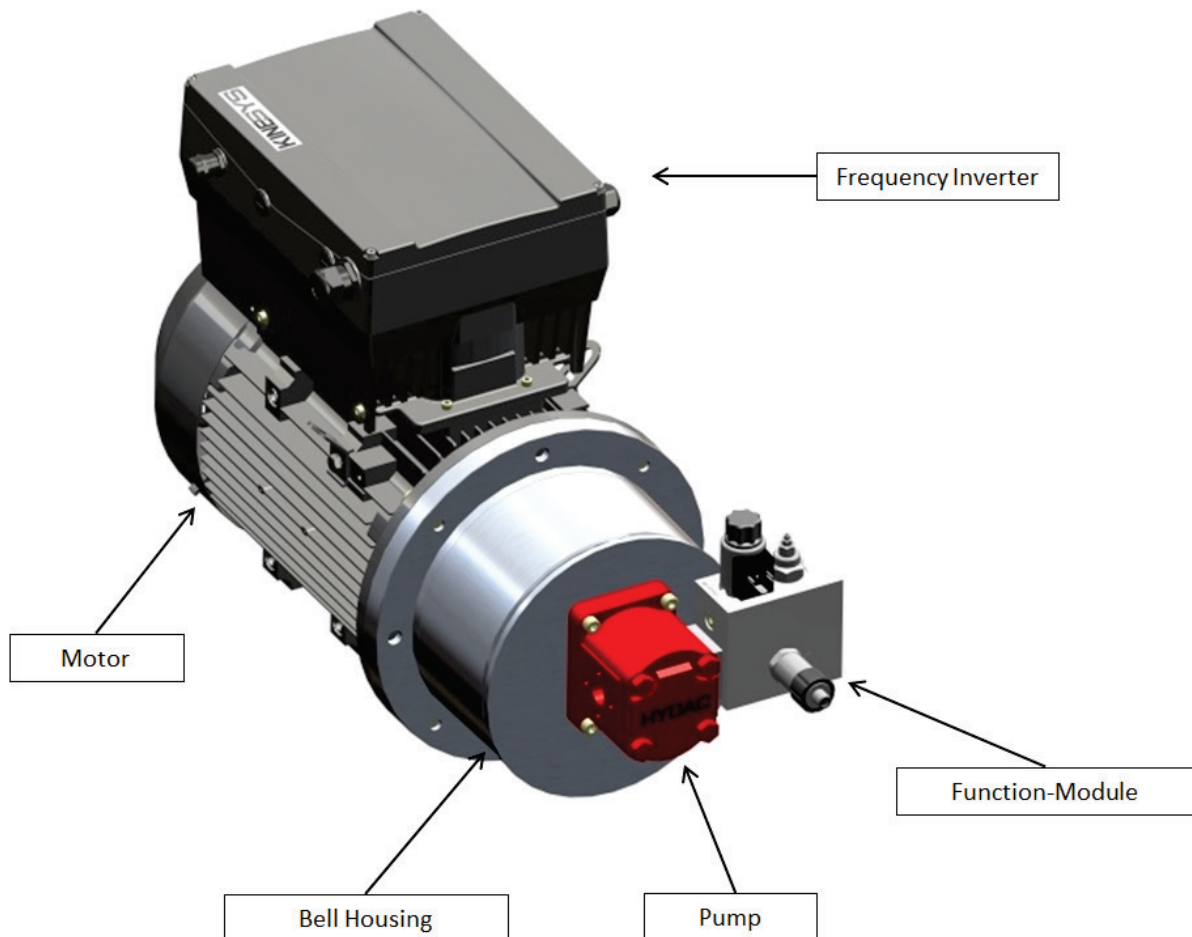

In the standard design, the DVA-Kit is made up of a standard electric motor with an integral frequency inverter, external gear pump (including support and adapter plate) and a hydraulic function module.

Variants

- In the horizontal installation variant the DVA-Kit is delivered fully assembled
- In the vertical installation variant for tank installation the function module is delivered separately

2.2 Additional options

Forced ventilation

When the motor pump unit is operated below half the nominal speed at full pressure, the motor's own ventilation is insufficient. An external fan is optionally available for such applications.

Accumulator charging module

The DVA-Kit can be supplied with an accumulator charging module. This allows hydraulic functions with low flow-rate requirements to be covered by the accumulator. This increases the dynamics in the event of leakage compensation or reduces the motor's duty cycle, which results in greater energy efficiency.

Pumps

HYDAC external gear pumps PGE size 2 (PGE102) are used in the standard version.

Optionally, other HYDAC PGE external gear pumps or PGI internal gear pumps can be used.

Fieldbus

The system can be coupled to a controller via a fieldbus. This enables target values to be specified via the bus and the status to be read.

Possible fieldbus systems:

- Profibus
- EtherCAT
- CANopen
- ProfiNET

2.3 Mounting examples

Horizontal installation variant

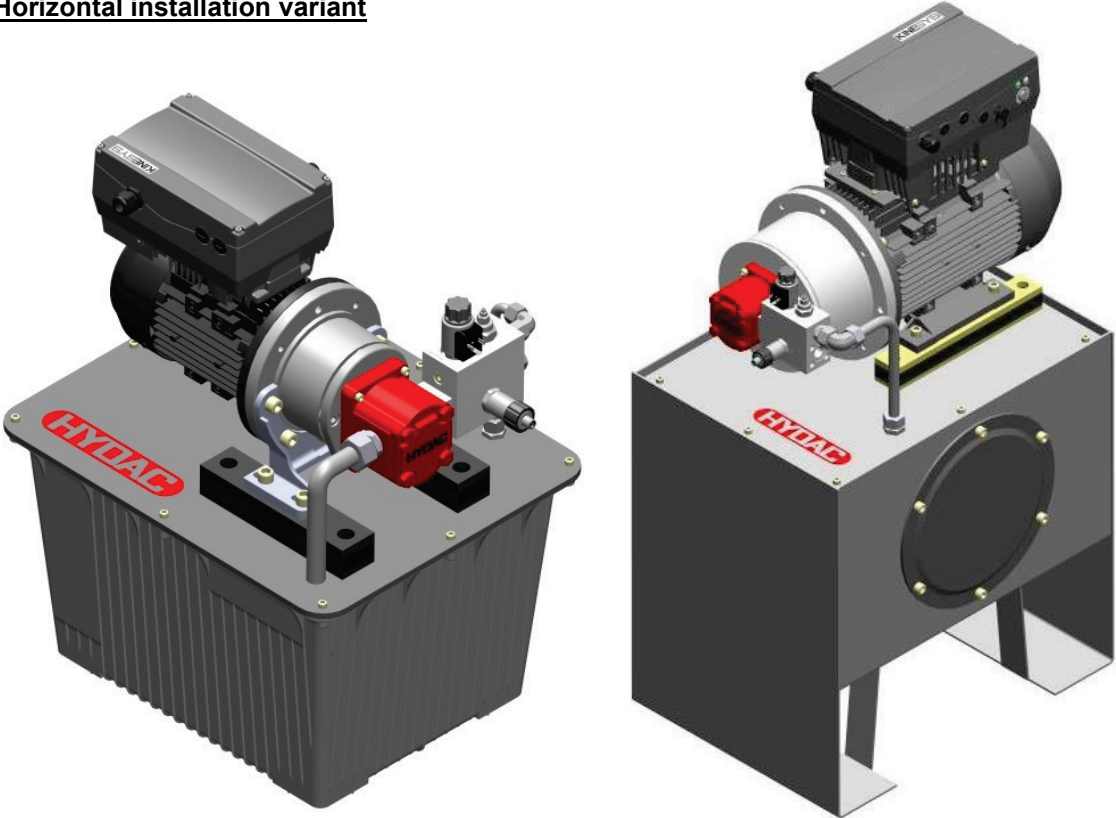

Vertical installation variant

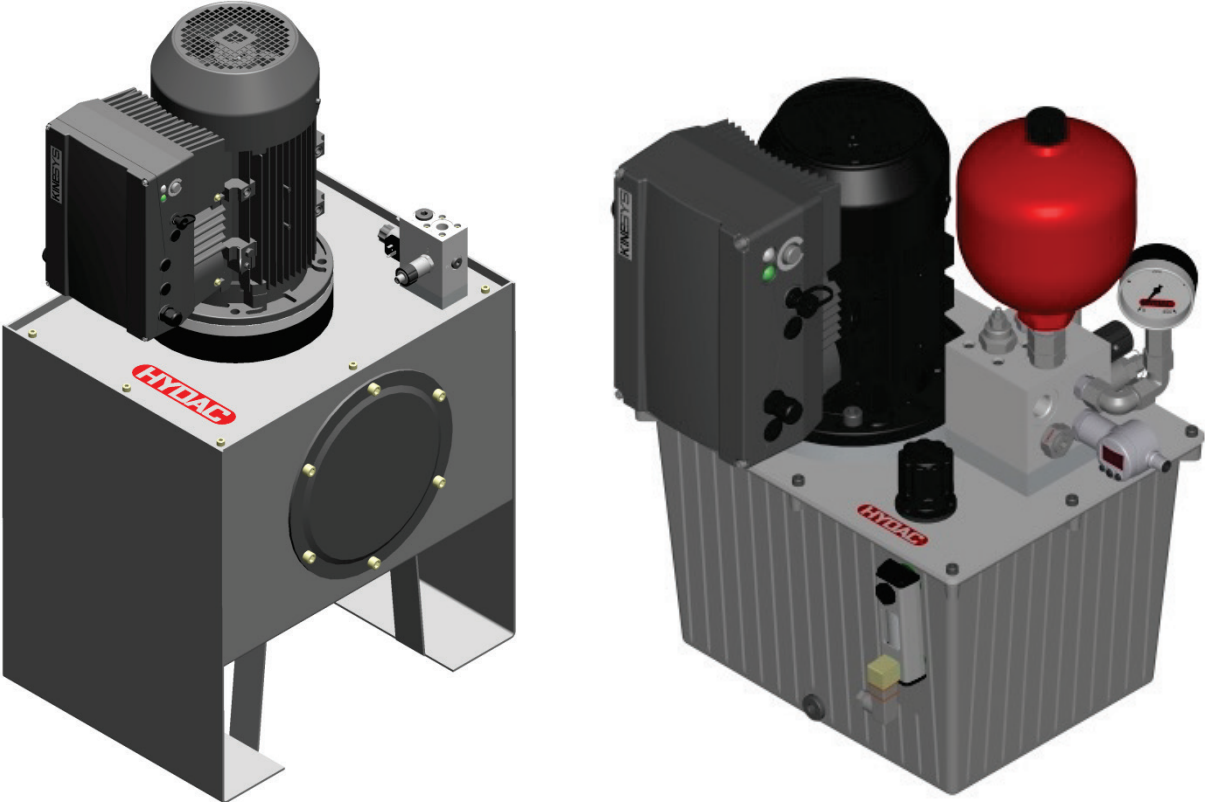

2.4 Function modules

The function module is supplied for a horizontal installation position with the adapter plate flanged to the pump. It is generally possible to install the function module externally, for example in the vertical installation variant.

2.4.1 Function module with block function 1

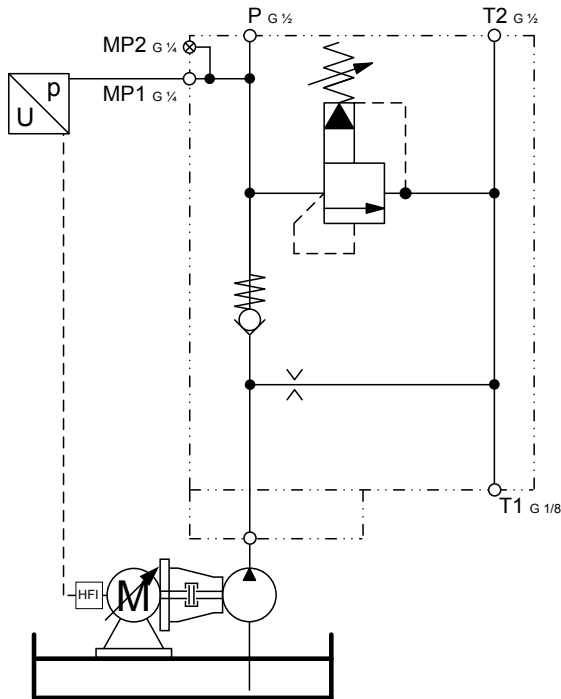

In the function module with block function 1, a bypass with orifice plate is provided.

The minimum volume flow required for the minimum pump speed is channelled away through this bypass.

The volume flow that is actually available at the supply connection (the function module's pressure connection (P)) is thus lower than the pump volume flow ($Q_{at P} = Q_{pump} - Q_{orifice}$).

2.4.2 Function module with block function 2

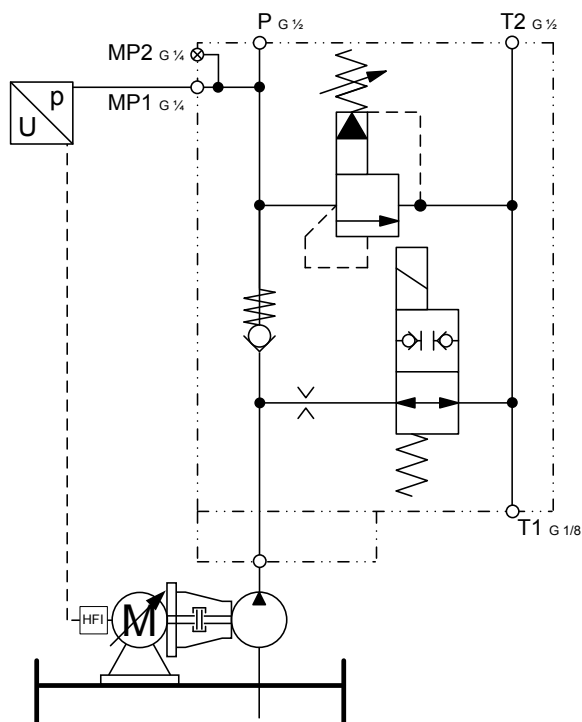

In the function module with block function 2, the switchable stop valve can be used to interrupt the volume flow through the orifice plate.

This makes the entire pump volume flow available at the supply connection.

2.4.3 Accumulator charging block

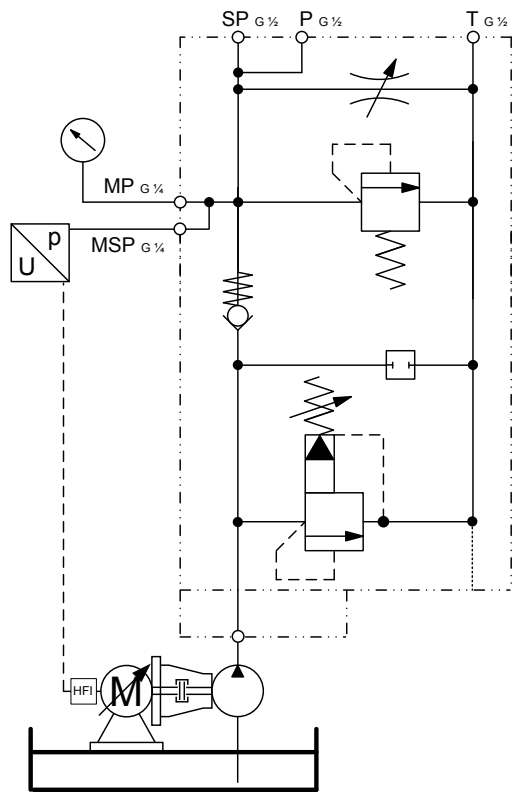

The accumulator charging block with block function 3 makes it possible to control the charging of the accumulator.

If an alternating flow rate is demanded over the entire adjusting range, an accumulator charging module with hydraulic accumulator can be used. This enables operation with pressure regulation to be combined with accumulator charge control. Refer also to section 5: Application examples.

The hydraulic accumulator can also be used to increase the system dynamics.

Example: Rapid, pressure-regulated movement of a cylinder with subsequent pressure maintenance (for leakage compensation).

2.4.4 Function module with block function 4

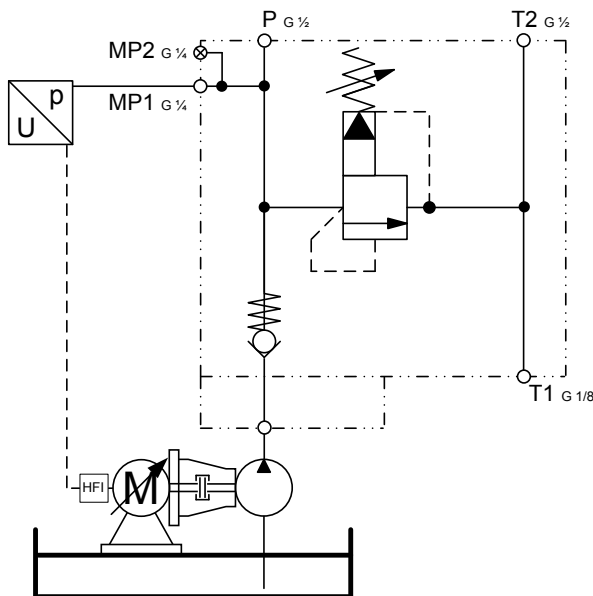

The function module with block function 4 includes components relevant for reliable pressure supply, such as a non-return valve and pressure relief valve.

It is important to note that the pump's minimum volume flow must always be taken off.

3 Technical data

3.1 Model code

Type code DVA-Kit

	DVA-Kit 16 - 40 - H - 0 - 0 0 - 0 - 0 - 0000
Name _____	
Flow rate Q_{nominal} [l/min] Q at nominal motor speed _____	
Pressure P_{nominal} [bar] Rated pressure _____	
Installation variation _____ H = horizontal V = vertical	
Blockfunction _____ 0 = without 1 = function module with block function 1 2 = function module with block function 2 3 = accumulator charging module 4 = function module with block function 4	
Mounting _____ 0 = without 1 = bell housing mounted* 2 = motor mounted* <small>* by installation variation horizontal</small>	
Damping type _____ 0 = without 1 = with damping ring* 2 = with damping rails** <small>* by installation variation vertikal ** by installation variation horizontal</small>	
Fieldbus _____ 0 = without 1 = Profibus 2 = EtherCAT 3 = CANopen 4 = ProfiNET	
Forced ventilation _____ 0 = without 1 = with	
Special design _____ 0000 = standard	

3.2 Pressure and flow rate setting ranges

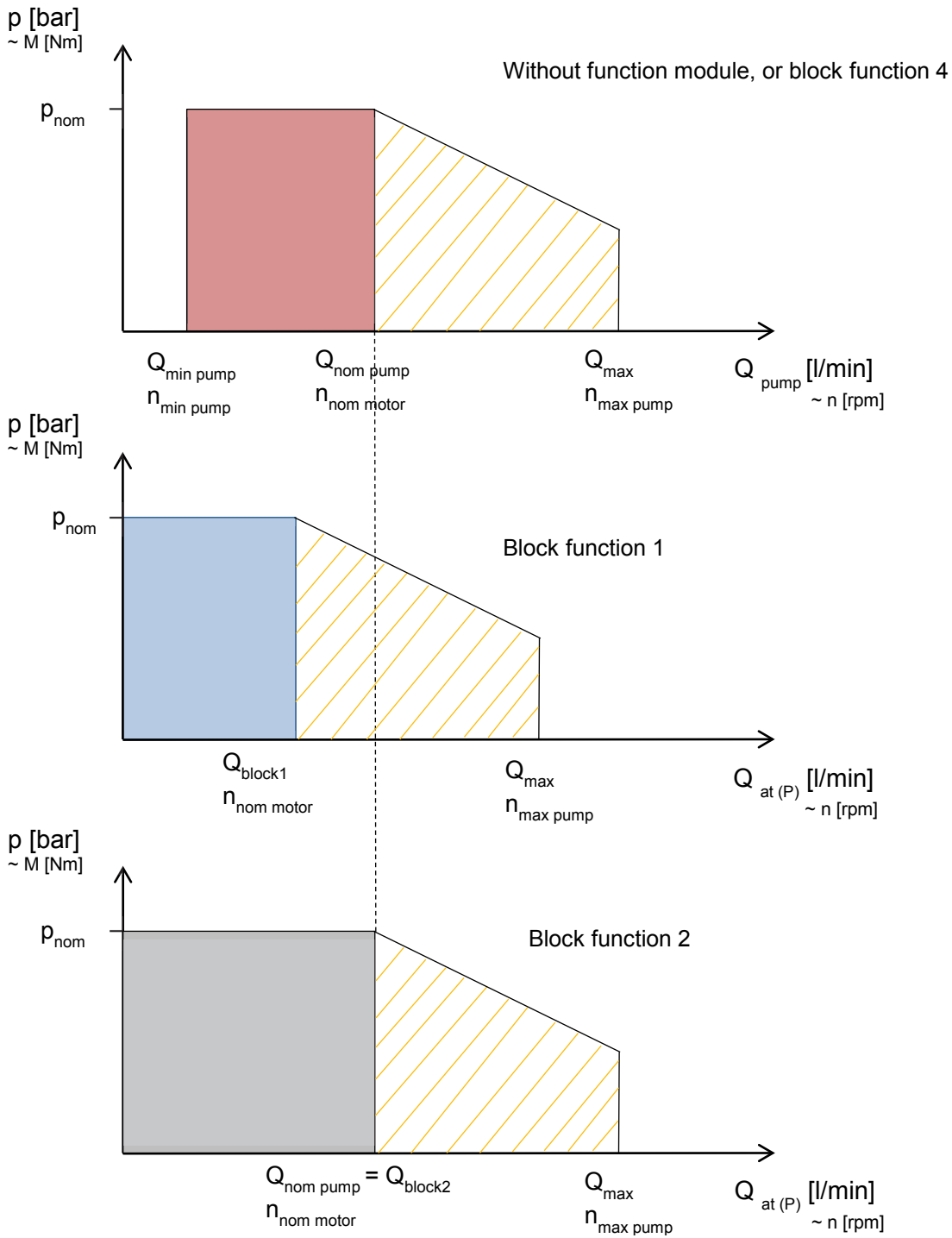

- Flow rate and pressure at the pump (without function module, or block function 4)
- Flow rate and pressure at supply connection (P) can be set as desired (block function 1)
- Flow rate at supply connection (P) can be realized with additional function (block function 2)
- Operating range for operation via nominal flow rate of pump, field weakening operation of motor

For the DVA-Kit, the flow rate or the pressure can be set as desired. The nominal flow rate Q_{nom} emanates from the nominal speed of the motor and the displacement of the pump.

A minimum flow rate arises based on the required minimum speed of the pump. To allow a volume flow below the minimum flow rate to be taken off at the supply connection, however, an orifice plate that consistently channels away the minimum volume flow is integrated into the function module (see section).

In the block function 1 design, the nominal flow rate is not available at the block's supply connection (P), as the required minimum volume flow is channelled away via the orifice plate across the entire speed range.

In the block function 2 design, the full nominal flow rate is available at the block's supply connection (P), as the orifice plate can be deactivated. Below the minimum speed, the valve is opened and the minimum volume flow is channelled away via the orifice plate.

In field weakening operation, the volume flow can be increased up to the maximum, pump-specific, flow rate Q_{max} . This does, however, result in an almost linear reduction in pressure.

Example:

When the motor is rotating at nominal speed, the pump supplies the nominal flow rate (Q_{nom}). At this operating point, the full operating pressure p_{nom} can be provided. Increasing the speed reduces the possible operating pressure by half.

- Doubling the flow rate halves the nominal operating pressure.

3.3 Electrical specifications

Inverter: HYDAC HFI-MM size A to D (0.55 kW to 22 kW)
 Motor: Standard asynchronous motors BG71 to BG180 (0.55 kW to 22 kW)
 Pressure measurement: HYDAC pressure transducer HDA

Inverter	Motor (2/4-pole)	Power
HFI-MM-A	BG71	0.55
HFI-MM-A	BG80	0.75
HFI-MM-A	BG80/BG90	1.1
HFI-MM-A	BG90	1.5
HFI-MM-B	BG 90/BG 100	2.2
HFI-MM-B	BG100	3
HFI-MM-B	BG112	4
HFI-MM-C	BG132	5.5
HFI-MM-C	BG132	7.5
HFI-MM-D	BG160	11
HFI-MM-D	BG 160	15
HFI-MM-D	BG 160/BG180	18.5
HFI-MM-D	BG 180	22

3.4 Operating mode

The DVA-Kit is designed for continuous operation (S1). Operating and environmental conditions are to be selected that do not result in the max. permissible oil temperature being exceeded. To ensure this, a heat exchanger or cooler must be integrated into the hydraulic system under certain circumstances.

Upon reaching the maximum drive temperature the DVA-Kit switches off automatically. The oil temperature can also be monitored with an automatic switch-off function on request.

3.5 Operating fluid

Only use hydraulic oil HLP to DIN 51524 Part 2 as the operating fluid.

Viscosity range	min. 10 mm ² /s to max. 380 mm ² /s
Optimum viscosity range	12 - 100mm ² /s
Cleanliness class ISO4406:1999	21/19/16 or better

4 Dimensions

4.1 DVA-Kits

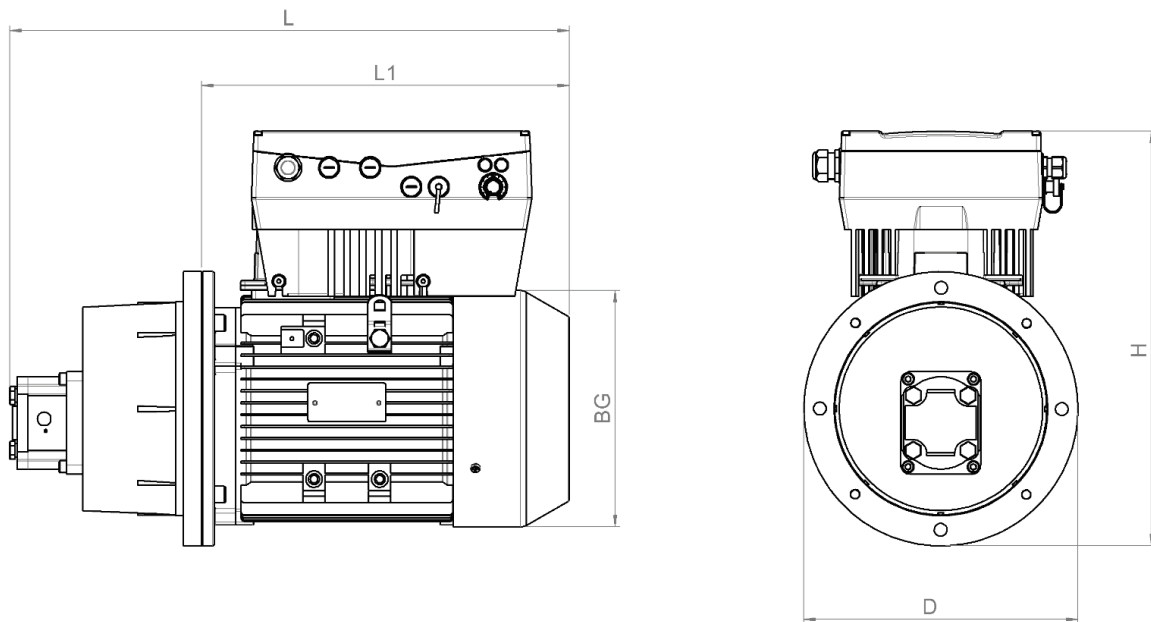

Power [kW]	L [mm] *	L1 [mm]	BG**	D [mm]	H [mm]
0.55	420 / 465	215 / 250	71 / 80	160 / 200	270 / 300
0.75	465	250	80	200	300
1.1	465 / 500	250 / 275	80 / 90S	200	300 / 320
1.5	500 / 525	275 / 300	90S / 90L	200	320
2.2	525 / 570	300 / 340	90L / 100L	200 / 250	330 / 350
3	570	340	100L	250	350
4	620	390	112M	250	380
5.5	645	395	132S	300	460
7.5	645 / 685	395 / 435	132S / 132M	300	460
11	795	500	160M	350	570
15	795 / 835	500 / 540	160M / 160L	350	570
18.5	795 / 875	500 / 580	160M / 180M	350	570 / 620
22	875 / 915	580 / 620	180M / 180L	350	620

* Dependent on the pump used: reference pump PGE102-1600 (length approx. 120 mm)

** The motor sizes are dependent on the motors selected (2-pole/4-pole)

4.2 Function module 45 block function 1 - 2 - 4

Maximum pressure 210 bar – maximum flow rate 45 l/min

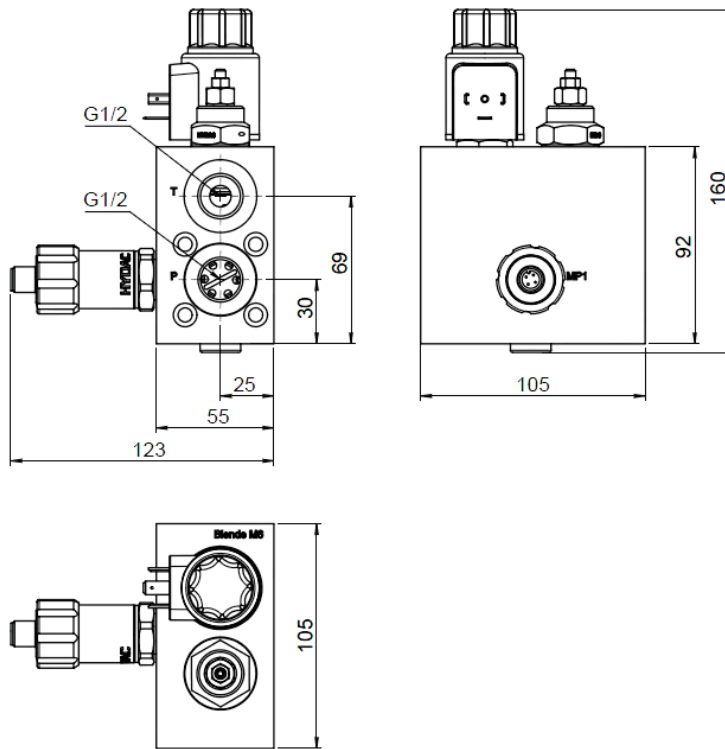

4.3 Function module 100 block function 1 - 2 - 4

Maximum pressure 210 bar – maximum flow rate 100 l/min

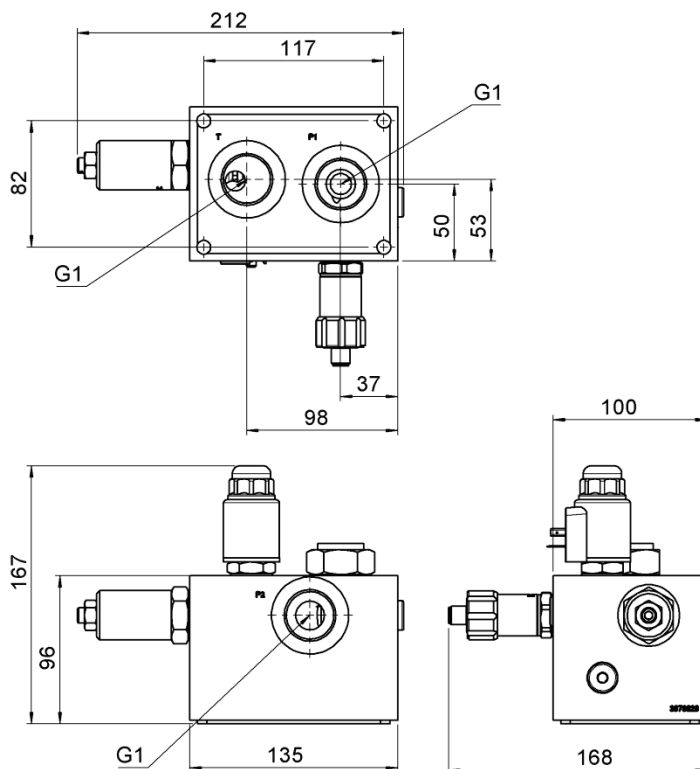

4.4 Accumulator charging block

Maximum pressure 210 bar – maximum flow rate 45 l/min

For flow rates above 45 l/min, we recommend a HYDAC DSV or SAF block.

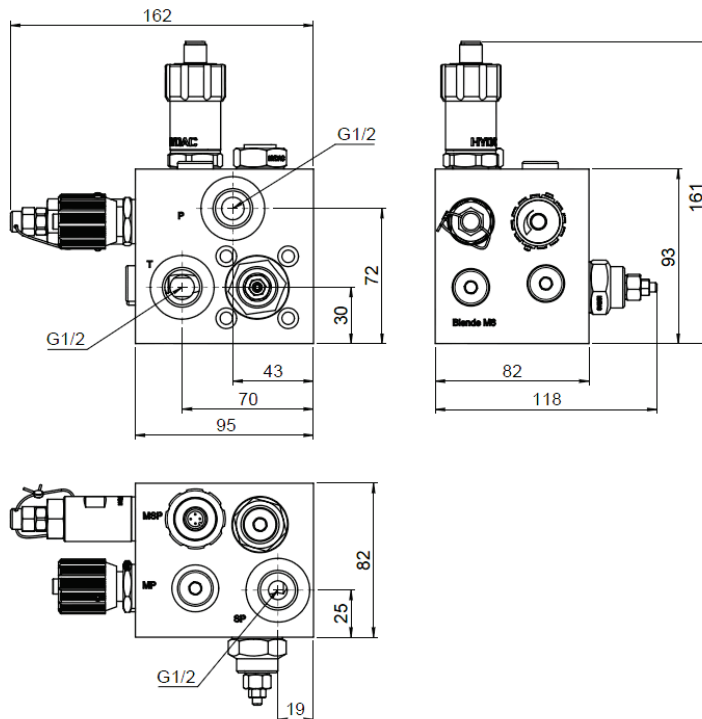

5 Application examples

Selected application examples are given below as illustrations. We will gladly assist you in creating the optimum setup for your drive system. Please contact us if you have any queries.

5.1 Setting flow rate

In the most straightforward case, the DVA-Kit can be used as a variable flow rate supply system by altering the speed. The flow rate can be set in the following ways:

- Rotary knob (potentiometer) on the inverter's housing
→ continuously adjustable configuration of speed/flow rate within permitted operating range
- Continuously variable specification of speed or flow rate via analogue input
→ e.g.: 0 to 10 V corresponds to the adjustment range between min. and max. flow rate
- Incremental specification of speed or flow rate via set values (max. seven)
→ e.g.: level 1: min. speed, level 2: half max. speed, level 3: max. speed
- Specification of speed or flow rate via fieldbus

For flow rate specification, the pressure is set automatically in accordance with the system.

This is a very straightforward way to realize speed control of a cylinder, for example.

5.2 Pressure/flow rate/position/temperature regulation

Sensors can be connected to the frequency inverter to regulate various process variables. The sensors are supplied with operating voltage via the frequency inverter and they return the measured value that needs to be regulated to the unit's analogue input.

The target value can be set in the following ways:

- Rotary knob (potentiometer) on the inverter's housing
→ e.g.: continuously adjustable configuration of target pressure value within permitted operating range
- Continuously variable specification of target value via analogue input
→ e.g.: 0 to 10 V corresponds to the adjustment range between min. and max. pressure
- Incremental specification of target value via set values (max. seven)
→ e.g.: level 1: min. pressure, level 2: half max. pressure, level 3: max. pressure
- Specification of target value via fieldbus

Flow rate regulation, position regulation or temperature-regulated flow rate provision can be realized in the same way as pressure regulation.

5.3 Block functions

A DVA-Kit is to be used to move a press's hydraulic cylinder to the pressing location as quickly as possible and then apply pressure with pressure regulation. After pressing, the cylinder is to be retracted as quickly as possible. This example will be used to describe the effect of the block functions.

Required:

Flow rate, extension: 10 l/min @ 30 bar

Flow rate, pressing: 1 l/min @ 140 bar

Flow rate, retraction: 10 l/min

Without block function or block function 4:

Pump: PGE101-365

For nominal motor speed: 2940 rpm → nominal flow rate: approx. 10 l/min

For minimum pump speed: 750 rpm → minimum flow rate: approx. 2 l/min

Nominal pressure: 140 bar

Without block function, the pump conveys 10 l/min at the motor's nominal operating point. This flow rate is available at the pump's pressure connection. The minimum flow rate, determined by the pump's minimum speed, is 2 l/min.

→ Movement at 10 l/min is possible

→ Movement at 1 l/min is not possible, because of the pump's minimum speed

Example model code: **DVA-Kit 10-140-H-0-10-0-0-0000**

Block function 1:

With block function 1, a function module is flanged to the pump. In the function module, a bypass is realized by means of an orifice plate that consistently channels away 2 l/min to guarantee the minimum speed or minimum flow rate. Accordingly, the pump's full flow rate is no longer available at the function module's pressure connection (P). Flow rates at the function module's pressure connection (P) can now be as low as desired.

→ $Q_{\text{function block}} = Q_{\text{pump}} - Q_{\text{orifice}}$

→ Movement at 10 l/min not possible: 2 l/min is channeled away via the orifice plate. The maximum flow rate available at pressure connection (P) is now 8 l/min.

→ Movement at 1 l/min possible: the pump conveys 3 l/min, 2 l/min is channeled away and 1 l/min is available at pressure connection (P).

Example model code: **DVA-Kit 10-140-H-1-10-0-0-0000**

Block function 2:

Block function 2 is based on the design of block function 1, with the addition of a bypass that can be deactivated via a 2/2-way valve.

When the system is in an operating state in which the minimum flow rate is taken off, the multi-way valve deactivates the bypass and the pump's full flow rate is once again available at the function module's pressure connection (P).

→ Movement at 10 l/min is possible: bypass closed

→ Movement at 1 l/min is possible: bypass open

Example model code: **DVA-Kit 10-140-H-2-10-0-0-0000**

5.4 Pressure-regulated operation with accumulator charge control

The accumulator charging block makes further levels of freedom available in the system, such as:

- High dynamics (pressure does not drop, or drops less, when flow rate decreases abruptly)
- Accumulator charge control regulated via the frequency inverter
- Accumulator charge control combined with pressure control

Accumulator charge control with pressure control:

For accumulator charge control with pressure regulation, the system is switched off when the upper pressure level is reached. If pressure drops to the lower pressure level, the system is switched on and operated in pressure-regulation mode.

The target value for pressure regulation is between the upper and the lower pressure level. As long as the system does not reach the upper pressure level, the pressure regulation keeps the pressure at the specified target value.

The upper pressure level is only reached when the pressure regulation cannot decrease the speed of the pump speed any further as it has already dropped to the minimum speed, causing pressure to rise. This can happen, for example, when flow rate is no longer needed but the pump continues to convey at minimum speed. The accumulator is then charged to the upper level and the motor is then switched off.

The diagram of the pressure and flow rate changes illustrates an example cycle for pressure-controlled operation with accumulator charge control.

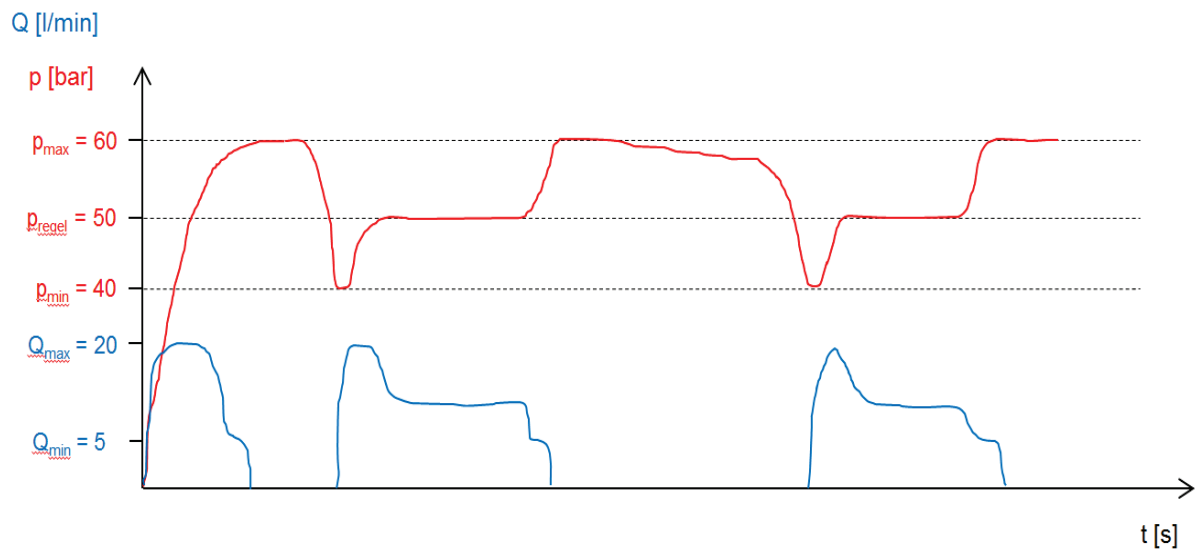

5.5 Operating range via nominal flow rate (field weakening operation)

The nominal flow rate is based on the nominal speed of the motor. A fixed flow rate is present at nominal speed, determined by the pump's geometrically determined conveying capacity. The speed of the motor can be increased above this level (field weakening). This does, however, reduce the possible torque and thus the possible operating pressure (see diagram in section 3.2).

Increasing the speed allows a greater flow rate to be conveyed into the system (for example, to reduce the process's cycle time).

Generally, a high flow rate is needed for rapid movement to a position, with the pressure only determined by the system's dynamic pressure, which is considerably lower than the actual process pressure. In this case, the speed of the pump can be increased via the nominal flow rate, as barely any torque or pressure is required.

If the system reaches the end position, in which the process pressure needs to be built up, the speed is reduced again to make corresponding torque available for the build-up of pressure.

6 Planning as interactive process

	Projectwork of DVA-Kit	Date: _____
Customer: _____ Need: _____ Piece/Year		
Project: _____		
<p>min volume flow: _____ l/min <input type="checkbox"/> without function module</p> <p>max volume flow: _____ l/min <input type="checkbox"/> block function 1</p> <p>max pressure: _____ bar <input type="checkbox"/> block function 2</p> <p style="margin-left: 150px;"><input type="checkbox"/> accumulator charge block</p> <p style="margin-left: 150px;"><input type="checkbox"/> block function 4</p> <p>Fixing position: <input type="checkbox"/> horizontal <input type="checkbox"/> vertical</p> <p>Mounting at horizontal: <input type="checkbox"/> bellhousing mounted <input type="checkbox"/> motor mounted</p> <p style="margin-left: 20px;"><input type="checkbox"/> without</p> <p>Damping type: <input type="checkbox"/> damping ring (at vertical)</p> <p style="margin-left: 20px;"><input type="checkbox"/> damping rails for bell housing</p> <p style="margin-left: 20px;"><input type="checkbox"/> damping rails for motor</p> <p style="margin-left: 20px;"><input type="checkbox"/> without</p> <p>Fieldbus: <input type="checkbox"/> Profibus <input type="checkbox"/> EtherCAT</p> <p style="margin-left: 40px;"><input type="checkbox"/> CANopen <input type="checkbox"/> Profinet</p> <p>Voltage: <input type="checkbox"/> 400V/50Hz <input type="checkbox"/> _____</p> <p>IP code: _____</p> <p>Ambient temperature: _____ °C</p> <p>Operating modes: <input type="checkbox"/> S1 Continuous oper. <input type="checkbox"/> S3 Intermittent oper. _____ %</p> <p><u>Sketch:</u> (Load cycle, p/Q area, ...)</p> <div style="border: 1px solid black; height: 150px; width: 100%; position: relative;"> <div style="position: absolute; top: -10px; left: 0; width: 100%; border-bottom: 1px solid black;"></div> <div style="position: absolute; left: -10px; top: 0; height: 100%; border-right: 1px solid black;"></div> <div style="position: absolute; top: 0; left: 0; width: 100%; height: 100%; background-image: linear-gradient(to right, 1px solid black, 1px transparent), linear-gradient(to bottom, 1px solid black, 1px transparent); background-size: 20px 20px;"></div> <div style="position: absolute; bottom: -10px; right: 0; width: 100%; border-top: 1px solid black;"></div> </div>		



Requested parameterization for DVA-Kit

Control mode:

- pressure control set volume flow volume flow control
- other / combination: _____

Starting conditions:

- digital signal start with line voltage fieldbus
- startprotect deactivated (automatically start after power breakdown)
- other: _____

reference value:

- Analog 0 ... 10 V Analog 0 ... 20 mA Analog 4 ... 20 mA
- potentiom. at housing preset speed (max. 7) fieldbus

Feedback value:

- Analog 0 ... 10 V Analog 0 ... 20 mA Analog 4 ... 20 mA

Speed / volume flow:

min.: _____ max.: _____

Description / further remarks:



Accumulators 30.000

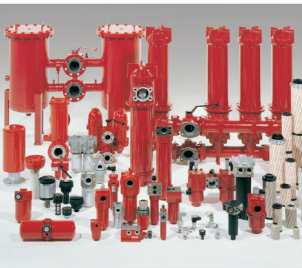

Filter Technology 70.000



Process Technology 77.000



Filter Systems 79.000

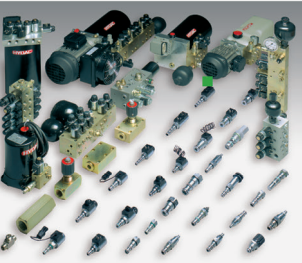

Compact Hydraulics 53.000



Accessories 61.000





Electronics 180.000



Cooling Systems 5.700

Global Presence. Local Expertise. www.hydac.com



-  HYDAC Head Office
-  HYDAC Companies
-  HYDAC Sales and Service Partners

HYDAC INTERNATIONAL

HYDAC INTERNATIONAL
GMBH

Industriegebiet
66280 Sulzbach/Saar
Germany

Tel.:
+49 6897 509-01
Fax:
+49 6897 509-577

E-mail: kinesys@hydac.com
Internet: www.hydac.com