

BL Series

Spin-on

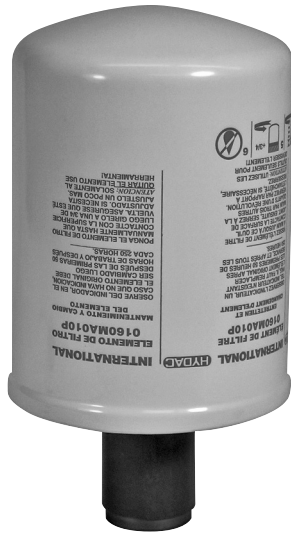

Specifications:

- Maximum flow rate: 110 scfm /850 gpm
- 3 or 10 micron
- Steel Canister
- 10 micron Betamicon®
- Replaceable element

Hydraulic Symbols

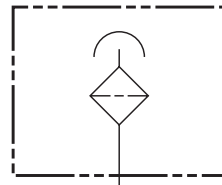

Dimensions

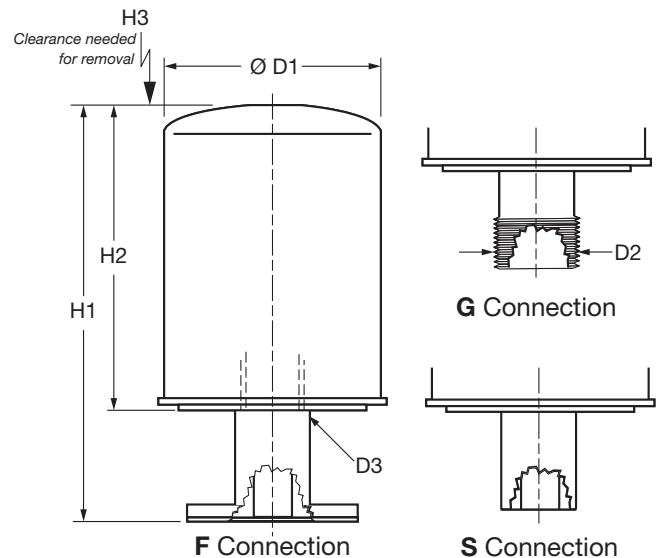

Size	Ø D1	D2 NPT	D3	H1 (F or S)	H1 (G)	H2	H3
BL...80	3.67 (93)	3/4"	1"-12UNF-2B	-	7 (178)	5.4 (137)	0.75 (19)
BL...160	5.00 (127)	1 1/4"	1 1/2"-16UN-2B	9.25 (235)	8.75 (222)	7 (178)	1.00 (25.4)
BL...180	5.00 (127)	1 1/4"	1 1/2"-16UN-2B	13.25 (337)	12.75 (324)	11 (279)	1.00 (25.4)
BLT...160	5.33 (136)	1 1/4"	1 1/2"-16UN-2B	9.25 (235)	8.75 (222)	7 (178)	1.00 (25.4)

Notes:

1. Dimensions are in inches/(mm).
2. Dimensions are for general information only, all critical dimensions should be verified by requesting a certified print.

Mounting Hole Pattern for Flange Connection (F)

(Flange Interface to DIN 24557/T2)

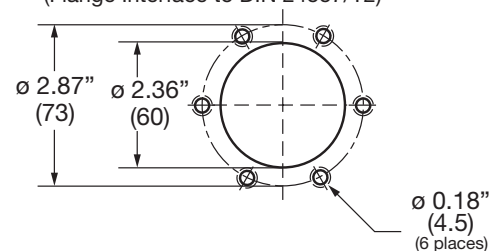

Model Code

BL P 160 G 10 W 2.0

Filter Type

- BL = Spin-on Breather
- BLT = Spin-on Breather with Dehumidifying Element (size 160 only)/(in 3 micron only)

Filter Element Material

- P = Impregnated Paper
- BN = Betamicon®
- M = Desiccant (type BLT only)

Size

- 080 = 35 scfm (250 gpm) max.
- 160 = 110 scfm (850 gpm) max.
- 180 = 110 scfm (850 gpm) max.

Type of Connection

- G = Threaded
- F = Flanged (DIN 24557/T2)
- S = Weld Fitting

Filtration Rating (micron)

- 3 = 3µm Air Filtration (paper only)
- 5 = 5µm Air Filtration (Betamicon Only)
- 10 = 10µm Air Filtration

Gauge Options

- W = Without Indicator

Type Connection

Type	G(Threaded)	F(Flanged)	S(Welded)
1.0 = BLT 160	1 1/4" NPT	DIN 24557/T2	Weld Fitting
2.0 = 160/180	1 1/4" NPT	DIN 24557/T2	Weld Fitting
3.0 = 080	3/4" NPT	-	-

Modification Number (standard)

Note: Low temperature options available. All breathers are available with special options and materials. Please contact the factory.

BREATHERS

BL Series

Spin-On (Components)

Replacement Elements



(Paper Media)

Size	3 Micron		10 Micron	
	Part. No.	Model Code	Part No.	Model Code
080	02058079	0080 MA 003 P	02058058	0080 MA 010 P
160	02058114	0160 MA 003 P	02058116	0160 MA 010 P
180	02057912	0180 MA 003 P	02058121	0180 MA 010 P

(Betamicron Media)

Size	3 Micron		5 Micron		10 Micron	
	Part. No.	Model Code	Part No.	Model Code	Part No.	Model Code
080	N/A		02059423	0080 MA 005 BN	02059424	0080 MA 010 BN
160	02059434	0160 MA 003 BN	02059435	0160 MA 005 BN	02059436	0160 MA 010 BN
180	02059438	0180 MA 003 BN	02059439	0180 MA 005 BN	02059440	0180 MA 010 BN

(Desiccant Media)

Size	3 Micron	
	Part. No.	Model Code
BLT 0160	01265765	0160 MU 003 M

Adapters

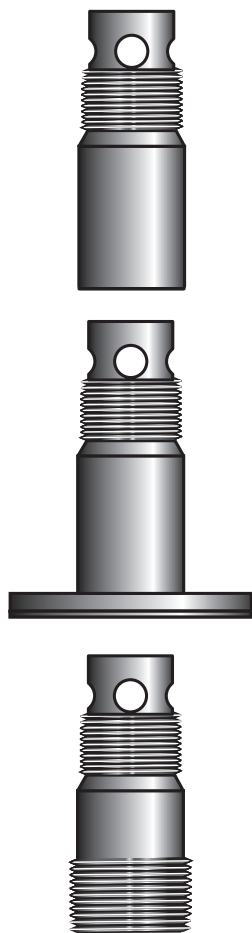

(S, Weld Fitting)

Size	Part No.	Model Code
080	N/A	
160	00416311	ADAPTER BL 160/180 S (PHOS)
180		

(F, Flanged)

Size	Part No.	Model Code
080	N/A	
160	00407646	ADAPTER BL 160/180 F (PHOS) ADAPTER BL 160/180 F (PHOS) (w/ Cardboard Gasket)
180	02073864	

(G, Threaded)

Size	Thread Size	Part No.	Model Code
080	3/4" NPT	02064393	ADAPTER BL 080 G 3/4" NPT NBR
160	1-1/4" NPT	02064394	ADAPTER BL 160/180 G 1 1/4" NPT NBR
180			

(Replacement Gaskets)

Part No.	Model Code
00247102	ELF 3 GASKET 6 HOLE CARDBD 83X58X1

Note: Low temperature options available. All breathers are available with special options and materials. Please contact the factory.