

# 1620 Series

## Test Points & Micro Bore Flex Hoses



### Description

HYDAC series 1620, guided piston design, Test Points are compact, self sealing couplings that provide access to hydraulic and pneumatic systems for pressure measurement to 9000 psi. Mating adapters or hose connections can be connected without loss of fluid while the system is operating. Test Points can also be used to take oil samples or to bleed air from hydraulic systems. They are available in 1620 (M16x2.0) connection threads with a variety of screw-in port configurations.

### Features

- Can be coupled and uncoupled under pressure without system shutdown or fluid loss
- Patented guided piston design for leak free performance at operating pressure to 9000 psi
- HYDAC guided piston design provides the following advantages over ball seal design:
  - Higher working Pressure
  - Better sealing characteristics particularly under high vibration
  - Less susceptible to fluid contamination
  - Can be used for gas as well as fluid
- Low temperature options available

### Applications

- Pressure measurement with gauges or sensors
- Fluid sampling
- Air bleeding

### Technical Data

#### Maximum Working Pressure

- 9000 psi (630 bar)  
*(see pressure utilization factor to adjust for operating temperature)*

#### Fluid Compatibility

- Suitable for petroleum-based fluids and gaseous media

#### Materials

- Zinc plated steel body (*standard*)
- Zinc plated metal cap (*standard*)

#### Seals

- Buna-N (*standard*)
- Fluoroelastomer (*standard*)

#### Temperature Range

- With metal cap and Buna-N seals:  
-13° to 212°F (-25° to 100°C)

#### Options

- Anti-vibration seal for metal cap

### Series 1620 Test Point

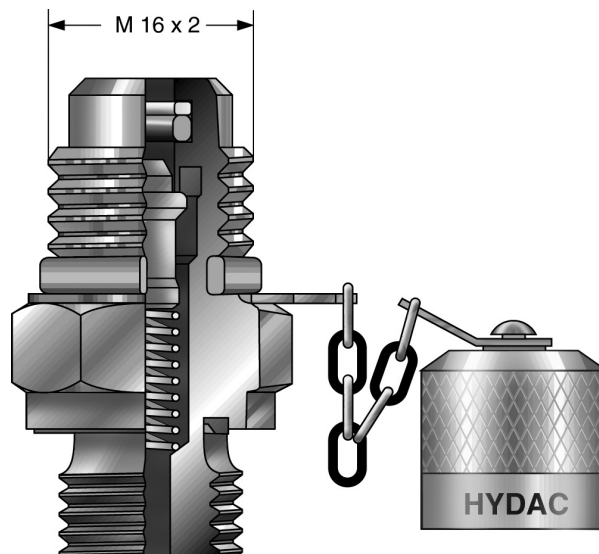

Guided Piston Design

# TEST POINTS

## 1620 Series

### Dimensions

Standard 1620 Test Point Connection with Cap

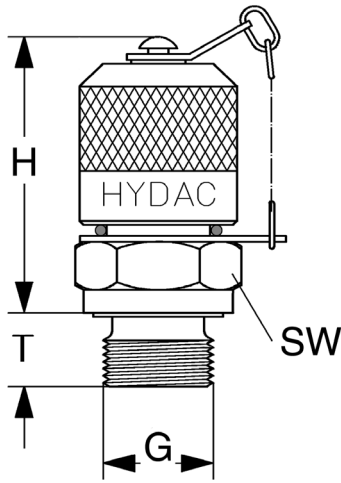

Select desired connection in the chart to the right

Note: All Test Points have a male connection thread (G)

### Carbon Steel Test Points (Zinc-Plated, Buna N Seals)

Thread G	P max	H (mm)	T (mm)	SW (mm)	Part No.
1/8 NPTF	5800 psi (400)	33	13	17	06003734
1/4 NPTF	5800 psi (400)	33	16.5	17	00639645
7/16-20 UNF	9000 psi (630)	37	9	17	06003735
9/16-18 UNF	9000 psi (630)	36	10	19	06003737
M 8x1	3600 psi (250)	41	8.5	17	06003731
M 10x1	3600 psi (250)	37.5	8.5	17	00629237
M 12x1.5	9000 psi (630)	36	10	17	00632615
M 14x1.5	9000 psi (630)	36	10	19	00632248
M 16x1.5	9000 psi (630)	36	10	22	06003732
ISO 228-G 1/8	5800 psi (400)	38	8	17	00689901
ISO 228-G 1/4	9000 psi (630)	36	10	19	00680107
ISO 228-G 3/8	9000 psi (630)	36	10	22	06003733
ISO 7/I-R 1/8	5800 psi (400)	33	13	17	06003738
ISO 7/I-R 1/4	9000 psi (630)	33	13	17	06003739

### Carbon Steel Test Points (Zinc-Plated, Fluoroelastomer Seals)

Thread G	P max	H (mm)	T (mm)	SW (mm)	Part No.
1/8 NPTF	5800 psi (400)	33	13	17	06007199
1/4 NPTF	5800 psi (400)	33	13	17	06007200
7/16-20 UNF	9000 psi (630)	37	9	17	06007029
9/16-18 UNF	9000 psi (630)	36	10	19	06007030
ISO 228-G 1/4	9000 psi (630)	36	10	19	00606304

### Stainless Steel Test Points (Fluoroelastomer Seals)

Thread G	P max	H (mm)	T (mm)	SW (mm)	Part No.
1/4 NPTF	5800 psi (400)	33	13	17	02701487
7/16-20 UNF	5800 psi (400)	33	16.5	17	02701486

Notes:

- Dimensions are in mm and psi (bar).
- Dimensions are for general information only, all critical dimensions should be verified by requesting a certified print.
- For port configuration drawings contact HYDAC.

### Micro Bore Flexible Hoses

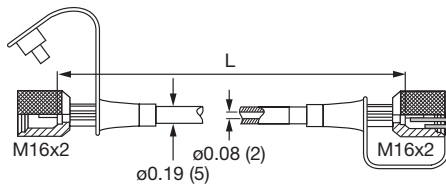

L (inches)	L (mm)	Part No.
8	200	06003723
12	300	06003724
16	400	00632633
20	500	06003725
25	630	06003726
31	800	00682857
39	1000	00632634
49	1250	06003727
59	1500	00682858
79	2000	00682859
98	2500	00682860
126	3200	06003728
157	4000	06003729
197	5000	06003730
236	6000	02701721
394	10,000	02701722

### Pressure Utilization Factor for Hoses

Operating Temp.	Factor	Max. Pressure
122°F (50°C)	100%	9000 psi
176°F (80°C)	86%	7740 psi
212°F (100°C)	77%	6930 psi

### Specifications

- Maximum working pressure 9000 psi (630 bar) at 122°F (50°C) (see pressure utilization factor to adjust for higher temperatures)
- Suitable for petroleum-based fluids
- Temperature range -4° to 122°F (-20° to 50°C) at max. pressure
- Polyamid core with polyester braid reinforcement and polyamid jacket
- Plastic dust cap
- 1620 female connection at both ends
- Bending radius: min. 20mm
- Hose ID  $\phi$  2mm
- Custom Hose Assemblies Available:  
NPT Male Thread, NPT Female Thread, JIC Male Hose, JIC Female swivel hose ends

# 1620 Series Adapters

## Direct Gauge Adapter

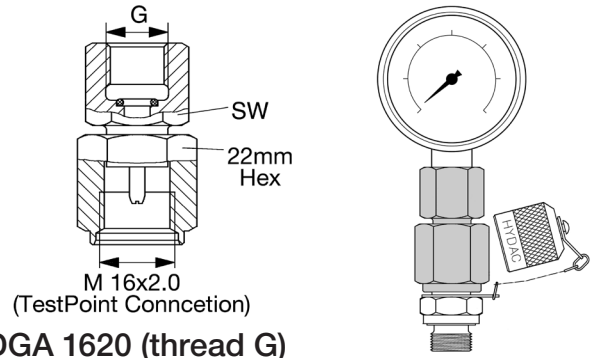
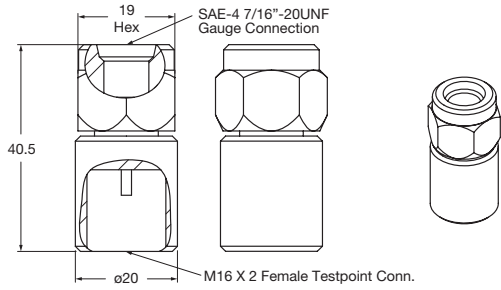

### Test DGA 1620 (thread G)

Thread G	Pmax	Part No.
SAE-4 7/16-20 UNF	10,000 (680)	02083643

Thread G	Pmax	SW	Part No.
ISO 228-G 1/4	9000 (630)	19	06003824
ISO 228-G 1/2	9000 (630)	27	06003825
1/4 NPT	9000 (630)	19	06003769

Note: There is no check valve inside of this adapter. For permanent gauge installation only.

## Hose to Gauge Bulkhead Adapter (with provisions for panel mounting)

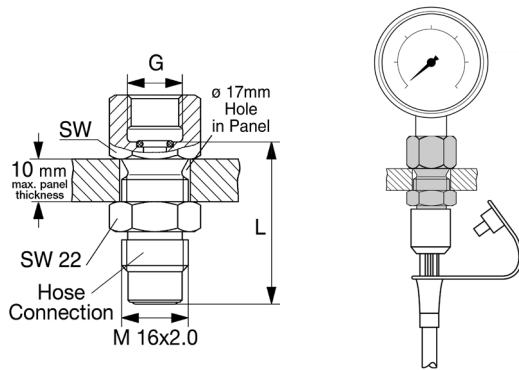

### Test HGA Bulk 1620 (thread G)

Thread G	Pmax	L	SW	Part No.
ISO 228-G 1/4	9000 (630)	38.5	19	06003822
ISO 228-G 1/2	9000 (630)	39.5	27	06003823
1/4 NPT	9000 (630)	38.5	19	06003768

Note: There is no check valve inside of this adapter. For permanent gauge installation only.

## Straight Coupling for Hose to Hose Connections

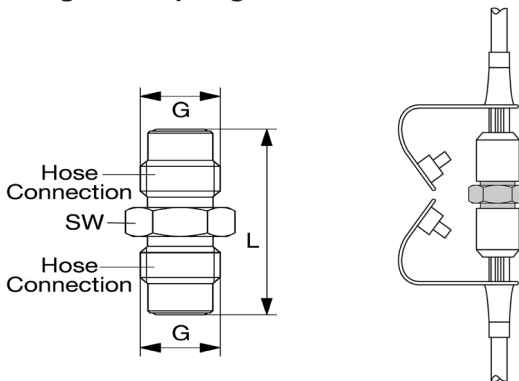

### Test HHA 1620 (thread G)

Thread G	Pmax	L	SW	Part No.
M 16x2.0	9000 (630)	42	22	00687889

Note: There is no check valve inside of this adapter.

## Standpipe Adapter 37° JIC Fitting

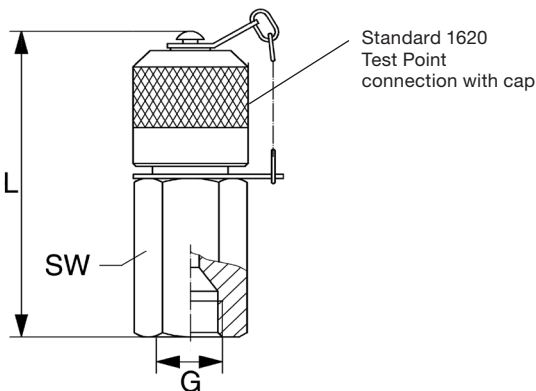

### Test 37DEG 1620 (thread G)

Thread G	Pmax	L	SW	Part No.
7/16"-20 UNF	9000 (630)	55	17	06003792
1/2"-20 UNF	6000 (420)	56.5	17	06003793
9/16"-18 UNF	4500 (315)	57.5	19	06003794
3/4"-16 UNF	4500 (315)	60.5	22	06003795

NOTES:

1. Dimensions are in mm and psi (bar).
2. Dimensions are for general information only, all critical dimensions should be verified by requesting a certified print.

# TEST POINTS

## 1620 Series

### Test Point Kits

#### 3 Gauge Kit



#### 5 Gauge Kit



Model Code	Part Number	3 Gauge Quantity	5 Gauge Quantity
<b>Test Point Kit 1620 3 Gauge</b>	<b>02081635</b>	-	-
<b>Test Point Kit 1620 5 Gauge</b>	<b>02081636</b>	-	-
HPG-63-1000-LM	02701547	1	1
HPG-63-1500-LM	02701548	0	1
HPG-63-2000-LM	02701549	1	1
HPG-63-3000-LM	02701550	0	1
HPG-63-5000-LM	02701551	1	1
TEST HOSE 1620 12"	06003724	1	2
TEST HOSE 1620 39"	00632634	1	2
<b>TEST HOSE 1620 79"</b>	<b>00682859</b>	<b>1</b>	<b>2</b>
Test Point 1620 (1/4 NPTF) MC/NBR	00639645	2	4
Test Point 1620 (7/16-20 UNF) MC/NBR	06003735	2	4
Test Point 1620 (9/16-18 NPTF) MC/NBR	06003737	2	4
<b>TEST DGA 1620 (1/4 NPT)</b>	<b>06003769</b>	<b>1</b>	<b>3</b>
TEST HGA BULK 1620 (1/4 NPT)	06003768	1	3
TEST HHA 1620	00687889	1	3

## 1215 Series

### Test Points *(M12 x 1.5 Threads)*

Standard design is zinc plated steel, buna seals, plastic cap and integrated safety device against vibration.

#### Test Hoses

L(in)	Model Code	Part No.
25	<b>Test Hose 1215 25"</b>	<b>02701307</b>
59	<b>Test Hose 1215 59"</b>	<b>02701377</b>

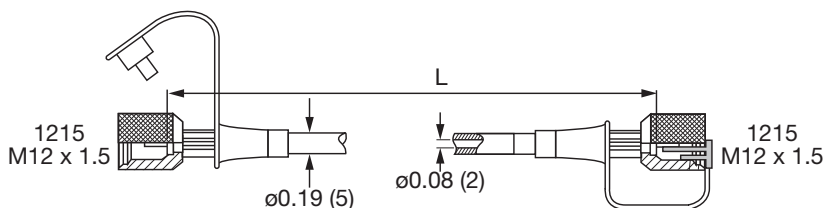

#### Dimensions

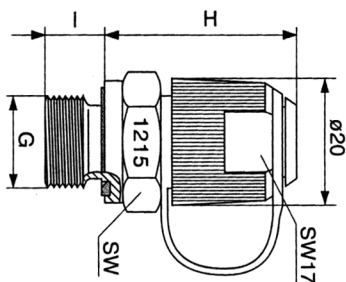

Thread (G)	p (max)	H	I	SW	Model Code	Part Number
ISO 228-G 1/8	5800 (400)	33	8	14	Test Point 1215 (G1/8) PC/NBR	-
ISO 228-G 1/4	9000 (630)	32	10	19	Test Point 1215 (G1/4) PC/NBR	-
1/8 NPTF	5800 (400)	29	12	14	Test Point 1215 (1/8 NPT) PC/NBR	-
1/4 NPTF	9000 (630)	29	15	14	Test Point 1215 (1/4 NPT) PC/NBR	02701305
<b>7/16-20 UNF</b>	<b>9000 (630)</b>	<b>32</b>	<b>9</b>	<b>17</b>	<b>Test Point 1215 (7/16-20 UNF) PC/NBR</b>	<b>02701293</b>
9/16-18 UNF	9000 (630)	32	10	19	Test Point 1215 (9/16-18 UNF) PC/NBR	02701335

#### Notes:

- Dimensions are in mm and psi (bar).
- Dimensions are for general information only, all critical dimensions should be verified by requesting a certified print.