

INDUSTRIAL COOLERS

HEX Series

Plate Heat Exchangers



Description

Heat exchangers are used to exchange heat between two fluids. Plate heat exchangers are high performance components and provide a high level of efficiency combined with compact dimensions and low weight. Their efficiency reduces the amount of cooling water required for heat transfer which results in low operating costs.

Features

Plates and connections are manufactured from stainless steel to AISI 316, 1.4401, vacuum-brazed with copper. The special molding of the plates produces the turbulent flow necessary for effective heat transfer and provides the plate heat exchanger with a high level of mechanical strength. Nickel brazed option available.

Applications



Agricultural



Automotive



Construction



Gearboxes



Industrial



Elevators



Commercial
Municipal



Power
Generation



Pulp & Paper



Railways



Shipbuilding



Steel / Heavy
Industry

Hydraulic Symbol

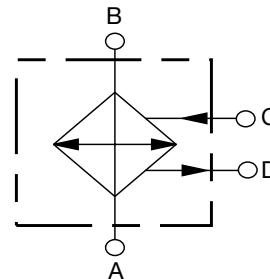

Operating Details

Medium:

- Water glycol (*coolants*)
- HFC operating fluids
- Water
- Oil

Contamination:

The quantity of particles in suspension should be less than 10 mg/l. Particle size < 0.6 mm (*spherical*).

Thread-like particles cause a rapid rise in pressure drops.

Temperature Range:

- 50° to 437°F (10° to 225°C)
(*freezing point and boiling point must be taken into consideration!*)

Pressure:

- max. 435 psi (30bar) (*static*)
- Test pressure: 650 psi

Corrosion:

The following limits refer to a pH value of 7

- free chlorine, CL₂ < 0.5 ppm
- chloride ions CL
< 700 ppm at 20 °C
< 200 ppm at 50 °C

Other Limits:

- pH 7 – 10
- sulphate SO₄²⁻ < 100 ppm
- [HCO₃⁻] / [SO₄²⁻] > 1
- ammonia, NH₃ < 10 ppm
- free CO < 10 ppm

The following ions are not corrosive under normal conditions:
phosphate, nitrate, nitrite, iron, manganese, sodium and potassium

Model Code

HEX 610 - 10 NPT

Series

HEX 610
HEX 615
HEX 722

Number of Plates

	10	20	30	40	50	60	70	80	100	120	150
610	x	x	x	x	x	x	x	x	x	x	x
615	x	x	x	x	x	x	x	x	x	x	x
722		x	x	x	x	x	x	x	x	x	x

(Other number of plates available - consult factory.)

Port Type

NPT = 610 + 615 series w/ 1" NPT: 422 series w/ 1-1/2" NPT
G = 610 + 615 series w/ G1" : 422 series w/ G1-1/2"

(Other port types available - consult factory.)

Mounting brackets must be ordered separately.

Note: Pipes must be connected so that connections are stress free. Linear expansion and vibrations from the pipes to the heat exchanger must be avoided.

Preferred HEX Models	Part Number
HEX 610-10 NPT QS	2582225
HEX 610-100 NPT QS	2582232
HEX 610-20 NPT QS	2582226
HEX 610-30 NPT QS	2582227
HEX 610-40 NPT QS	2582228
HEX 610-50 NPT QS	2582229
HEX 610-60 NPT QS	2582230
HEX 615-20 NPT QS	2582235
HEX 615-30 NPT QS	2582236
HEX 615-40 NPT QS	2582237
HEX 615-50 NPT QS	2582238
HEX 615-60 NPT QS	2582239
HEX 615-80 NPT QS	2582240

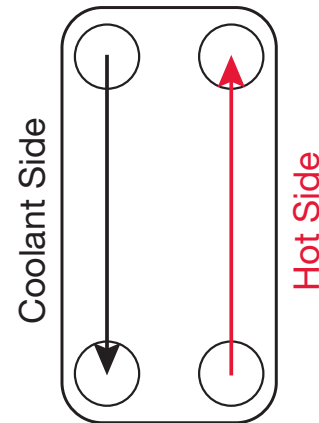

Fluid flow should be opposite per this picture.

Pressure Drop Across Heat Exchanger

This table is based on an ISO VG45 oil at 130°F and shows the pump flows with the 1,800 RPM motors. If other grades of oil are to be used, consult the sizing software. When using the 72 psi clogging indicator the pressure drop should not exceed 15 psi max across the heat exchanger. When using the 29 psi clogging indicator the pressure drop should not exceed 30 psi max across the heat exchanger.

Heat Exchanger Size	Pump 3.5 1.6 gpm (6.3 l/min)	Pump 7 3.3 gpm (12.6 l/min)	Pump 10 4.75 gpm (18 l/min)	Pump 15 7 gpm (18 l/min)	Pump 20 9.5 gpm (18 l/min)	Pump 30 14.5 gpm (55 l/min)	Pump 40 18.5 gpm (70 l/min)	Pump 50 23.5 gpm (90 l/min)	Pump 70 34 gpm (130 l/min)	Pump 100 47.5 gpm (180 l/min)
610-10	3	5	8	-	-	-	-	-	-	-
610-20	1	2	3	5	7	13.66	-	-	-	-
610-40	-	-	-	2	3	7.35	9.85	13.4	-	-
610-50	-	-	-	-	-	5.64	7.54	10.27	16.19	-
610-70	-	-	-	-	-	4.1	5.2	7	11.1	16.8
610-100	-	-	-	-	-	3	3.8	4.9	7.6	11.66
610-120	-	-	-	-	-	2.55	3.25	4.2	6.35	9.8
615-10	4	9	15	-	-	-	-	-	-	-
615-20	2	3.3	5	9	13	-	-	-	-	-
615-40	-	-	-	4	5	13.25	17.8	-	-	-
615-60	-	-	-	-	-	8.15	10.8	14.75	-	-
615-80	-	-	-	-	-	5.95	7.75	10.5	16.6	-

INDUSTRIAL COOLERS

Technical Data HEX Size 610

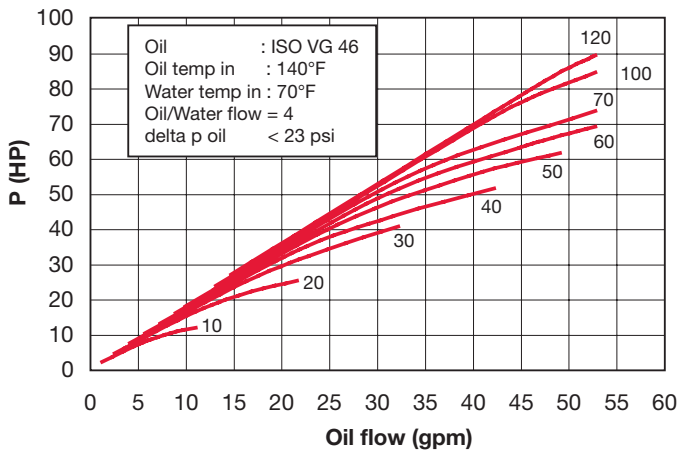

Number of plates (N)	H = 10 + Nx2.4 (mm)	lbs
10	34	5.5
20	58	8.4
30	82	11.2
40	106	14.0
50	130	17.0
60	154	19.8
70	178	22.6
100	250	31.2
120	298	37.0

HEX Size 615

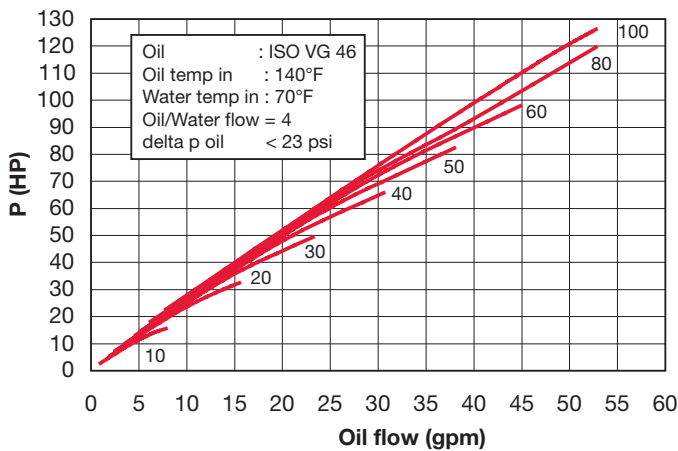

Number of plates (N)	H = 10 + Nx2.4 (mm)	lbs
10	34	9.2
20	58	14.3
30	82	19.4
40	106	24.4
50	130	29.7
60	154	35.5
80	202	44.6

HEX Size 722

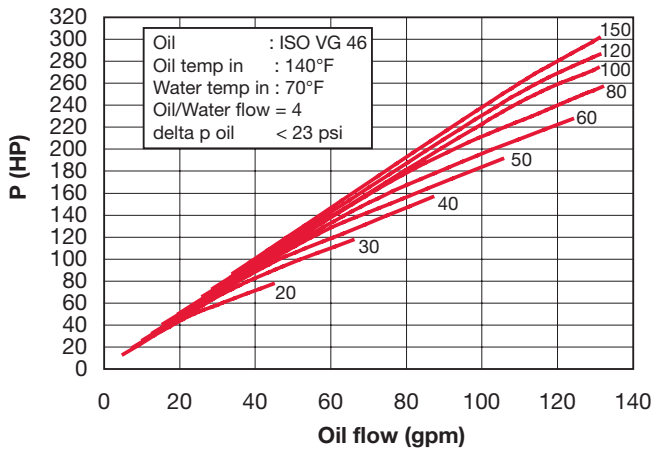

Number of plates (N)	H = 10 + Nx2.85 (mm)	lbs
20	67	34.7
30	95.5	44.5
40	124	54.1
50	152.5	63.8
60	181	73.5
80	238	92.8
100	295	112.2

The cooling capacity is also dependent on the viscosity class. At a lower viscosity class the cooling capacity increases, at a higher viscosity class it decreases. In order to make an accurate calculation, the following details are required:

- type of oil
- permissible tank temperature
- required outlet temperature of the oil or necessary cooling capacity
- inlet temperature of the water and maximum water quantity

Selection Program

The cooler selection program calculates the correct heat exchanger in the case of non-standard operating data.

Please contact HYDAC Product Group - Cooling System Division

Dimensions HEX Size 610

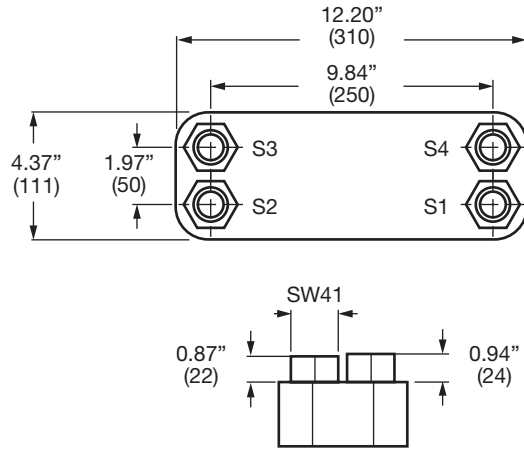

Mounting Bracket (PN 443281)

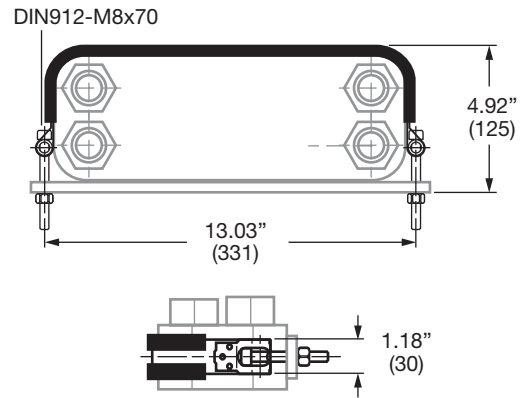

HEX Size 615

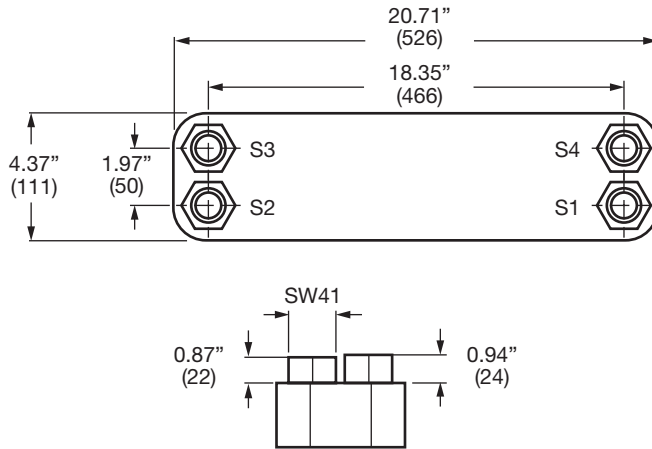

Mounting Bracket (PN 3014029)

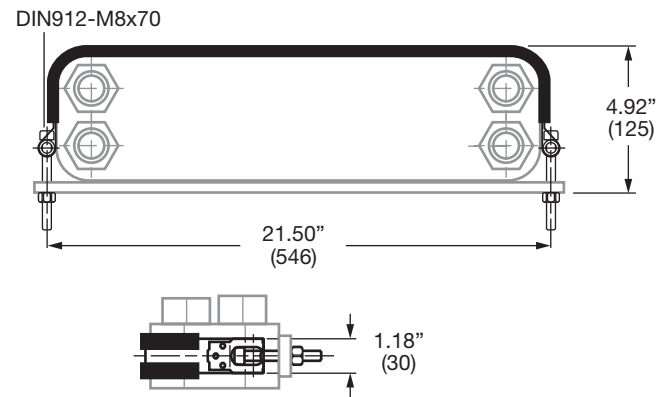

HEX Size 722

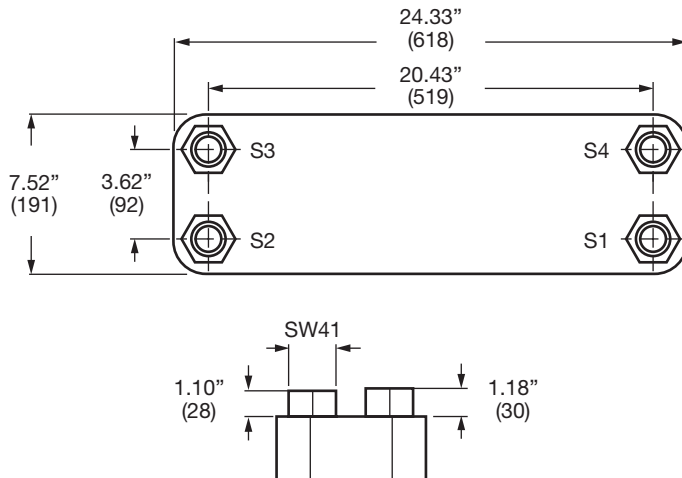

Mounting Bracket (PN 3013884)

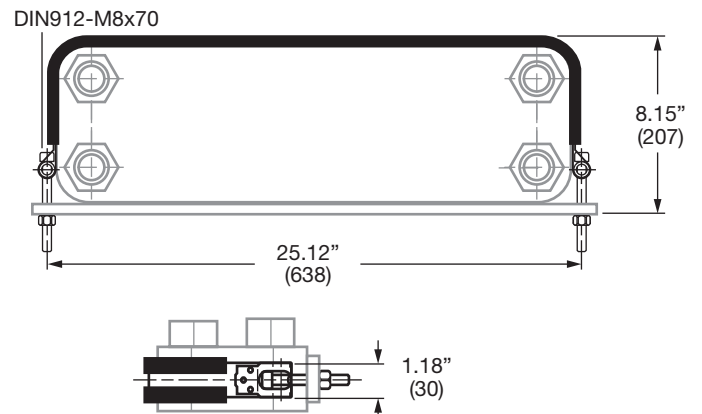

Please note: For mounting heat exchangers with 60 plates and above, two clamps are recommended.

Dimensions are for general information only, all critical dimensions should be verified by requesting a certified print. Dimensions are in inches (mm).