

Hydraulic Safety I/O Module HY-TTC 30XSH

General Description

The HY-TTC 30XSH is an I/O slave module which is designed for distributed safety applications demanding a high number of PWM outputs in remote locations.

The HY-TTC 30XSH was developed following the international standard EN ISO 13849 and is certified by TÜV NORD. It meets the requirements of Functional Safety according to Performance Level (PL) c.

The HY-TTC 30XSH is a member of the HY-TTC 30X family, which consists of different I/O slave modules. The HY-TTC 30XSH is controlled using the CANopen® Safety protocol. It is part of a complete and compatible product range for the off-highway industry. The modules are protected by compact automotive style housings which are highly suited for rough operating conditions. They provide a wide range of flexible configurable I/Os and allow local current control using PWM outputs.

Specifications

Parameter		Unit
ECU Dimensions	147 x 92 x 38	mm
Dimensions for minimum connector release clearance	208 x 92 x 38	mm
Weight	330	g
Connector	48	pins
Operating Temperature	- 40 to + 85	°C
Operating Altitude	0 to 4000	m
Supply Voltage	8 to 32	V
Peak Supply Voltage	40	V _{max}
Max Idle Current	≤120	mA
Standby Current	≤1	mA
Total Load Current	24	A _{max}
Standards		
Functional safety	EN ISO 13849 PL c	
CE-Mark	2014/30/EU 2006/42/EC	
E- Mark	ECE-R10 Rev.4	
EMC	EN 13309 ISO 14982 CISPR 25 EN 61000-6-2/-4	
ESD	ISO 10605	
Electrical	ISO 16750-2 ISO 7637-2,-3, limited to 40 V by external load dump protection	
Ingress Protection	EN 60529 IP67 ISO 20653 IP6k9k	
Climatic	ISO 16750-4	
Mechanical	ISO 16750-3	
Communication Profile	CANopen® CiA DS 401	



Features

CPU Core

- Infineon XC22xx CPU 80 MHz
- 768 kByte int. Flash, 82 kByte int. RAM, 8 kByte EEPROM

Interfaces

- 1 x CAN, 125 kbit/s up to 1 Mbit/s,
- 1 x CAN bus termination configurable via connector pins
- 2 x node ID pins for optional configuration of CANopen® ID

Outputs

- 6 x PWM OUT or digital OUT, up to 3 A, high side switch with current-measurement, overload and open load detection, PL c capable
alternative use
digital timer IN (10 Hz - 10 kHz) or analog IN 0 – 32 V both with integrated Pull-Up
- 2 x PWM OUT or digital OUT, up to 3 A, high side switch with overload detection, open load detection and support for high inrush current loads, PL c capable
alternative use
digital timer IN (10 Hz - 10 kHz) or analog IN 0 – 32 V both with integrated Pull-Up
- 2 x digital OUT, up to 3 A, low side switch used as redundant switch off path for high side PWM outputs
- 6 x PVG OUT
15 % - 85 % BAT+ with PVG valves
alternative use
voltage OUT 0 V - 75 % BAT+ with 10 kOhm low side load or analog IN 0 - 32V

Inputs

- 4 x digital timer IN (0.1 Hz - 10 kHz), PL c capable if used in pairs
alternative use
analog IN, 0 to 32V
1x rotary encoder
configurable Pull-Up/Down in digital IN mode
- 2 x analog IN, configurable in software, input functions are PL c capable if used in pairs
0 - 5V / 10 V IN 0 - 25 mA IN
0 - 65 kOhm IN up to 25 mA LED control OUT
- 6 x analog IN, configurable in software, input functions are PL c capable if used in pairs
0 - 5V / 10 V IN 0 - 25 mA IN
up to 25 mA LED control OUT
- 2 x analog IN 0 - 32V, PL c capable if used in pairs
configurable Pull-Up/Down in digital IN mode

Other

- 1 x sensor supply 5 V, 100 mA
- Internal monitoring of board temperature, sensor supply, K15 input and battery voltage

Software

- CANopen® Safety I/O Module software preinstalled

All I/Os and interfaces are protected against short circuit to GND and BAT+, and can be configured by software.

All analog inputs use 10 bit resolution

All analog voltage inputs can be used as digital inputs with configurable switching levels and hysteresis

Dedicated power supply pins for high side outputs

For safety functions two PL c capable inputs of the same type have to be used in parallel to provide redundancy in case of a failure.

Details to the standards can be found in the User Manual.

Block Diagram

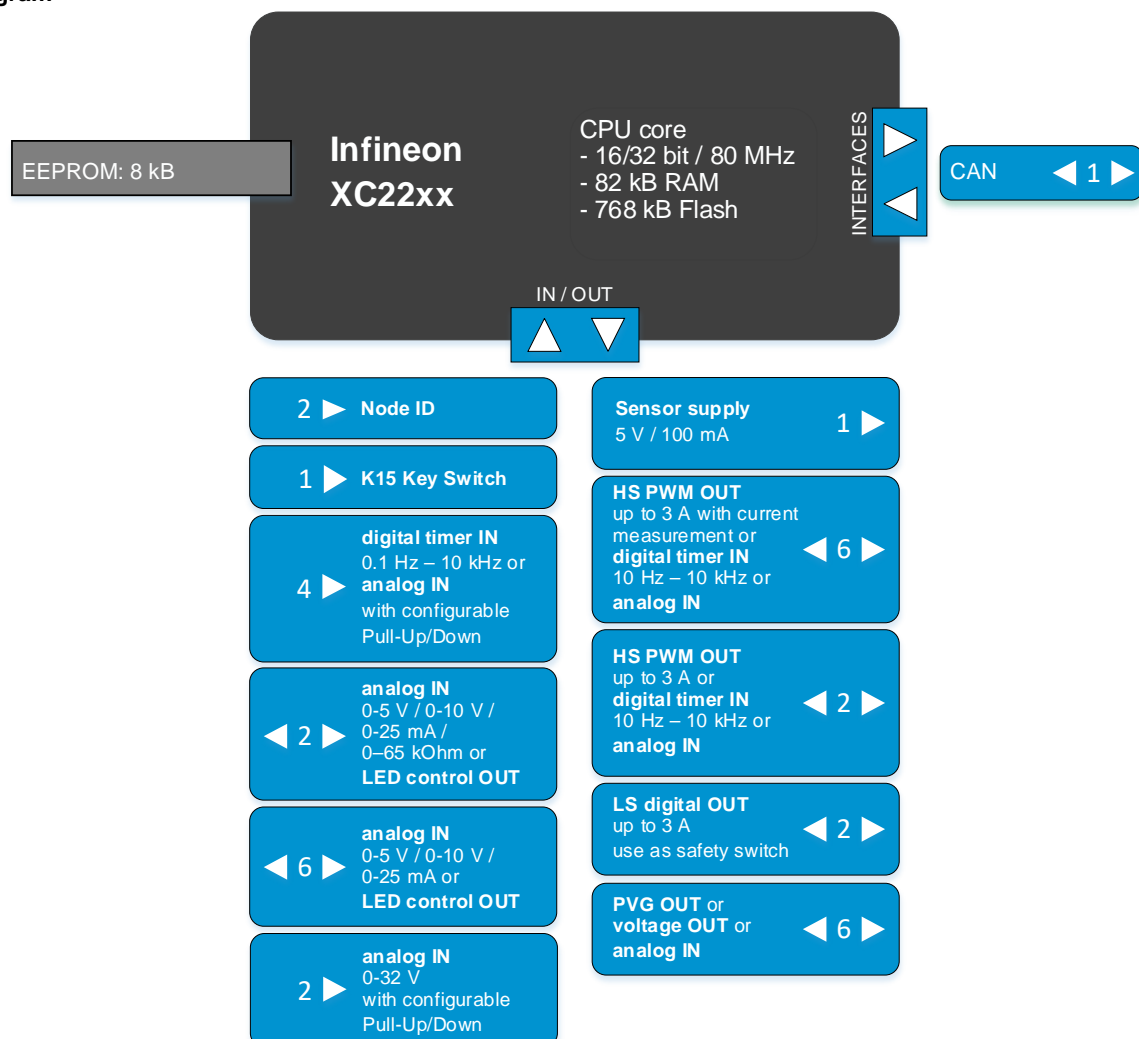

Housing and Connector

Aluminum die-cast housing

48-pin connector, 1 connector chamber

Mating connector: FCI PPI0001494 or PPI0001495
Molex 64320-1311 or 64320-3311

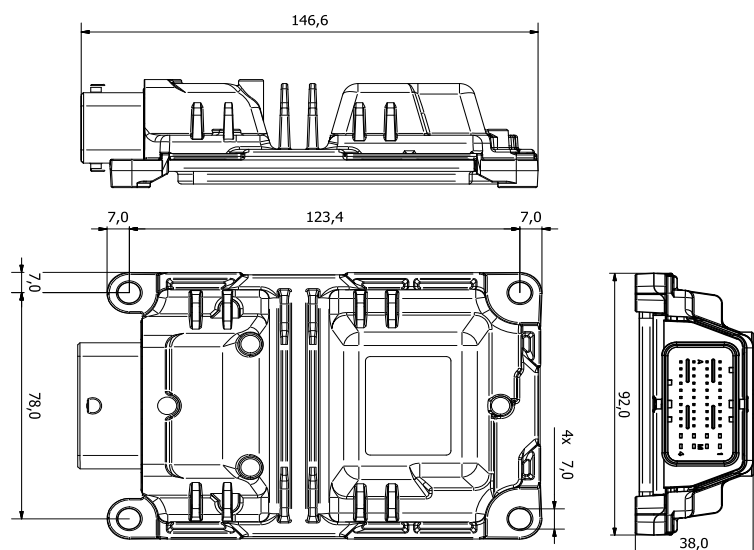

For further information, including price and availability, please contact products@ttcontrol.com

Subject to changes and corrections. HY-TTC 30XSH is a product name of TTControl GmbH. Other trademarks are the property of their respective holders. To the extent possible under applicable law TTControl hereby disclaims any and all liability for the content and use of this product flyer.