



Electronic Pressure Transmitter HDA 4300 with Flush Membrane ATEX Intrinsically Safe ATEX Dustproof Enclosure ATEX Non-sparking



Description:

The pressure transmitter HDA 4300 in ATEX version has been specially developed for use in potentially explosive atmospheres and is based on the HDA 4000 series.

As with the industrial version, the HDA 4300 in ATEX version has the field-proven ceramic measurement cell with thick-film strain gauge.

The pressure connection is achieved with an all-welded stainless steel front membrane filled internally with a pressure transfer fluid. The process pressure is transmitted hydrostatically to the measurement cell via the pressure transfer fluid.

This device is used for applications in which a standard pressure connection could become blocked, clogged or frozen by the particular medium used. Further applications include processes where the medium changes regularly and any residues could cause mixing or contamination of the media. Intended areas of application are, for example, the oil and gas industry, in mines, or in locations with high levels of dust, e.g. in mills.

Protection types and applications:

- I M1 Ex ia I Ma
- II 1G Ex ia IIC T6 Ga
- II 1/2G Ex ia IIC T6 Ga/Gb
- II 2G Ex ia IIC T6 Gb
- II 3G Ex nA IIC T6, T5, T4 Gc
- II 3G Ex ic IIC T6, T5, T4 Gc

- II 1D Ex ia IIIC T85°C Da
- II 1D Ex ta IIIC T80/90/100°C Da
T₅₀₀ T90/T100/T110°C Da
- II 2D Ex tb IIIC T80/90/100°C Db
- II 3D Ex tc IIIC T80/90/100°C Dc
- II 3D Ex ic IIIC T80/90/100°C Dc

Special features:

- Pressure connection has a flush membrane
- Accuracy: $\leq \pm 0.5\%$ FS typ.
- Certificates:
KEMA 05ATEX1016 X
KEMA 05ATEX1021
- Robust design
- Very small temperature error
- Excellent EMC characteristics
- Excellent durability

Technical data:

Input data		
Measuring ranges	-1 .. 1; -1 .. 9; 1; 2.5; 4; 6; 10; 16; 25 bar	
Overload range	3; 32; 3; 8; 12; 20; 32; 50; 80 bar	
Burst pressure	5; 48; 5; 12; 18; 30; 48; 75; 120 bar	
Mechanical connection	G1/2A DIN 3852 G1/2 with additional front O-ring seal G1/4 with additional front O-ring seal	
Pressure transfer fluid	Silicon-free oil	
Torque value	45 Nm for G1/2, G1/2 A 20 Nm for G1/4	
Parts in contact with medium ¹⁾	Stainless steel: 1.4435; 1.4301 Seal: FPM O-ring: FPM	
Output data		
Output signal, permitted load resistance	4 .. 20 mA, 2 conductor R _{Lmax} = (U _B - 12 V) / 20 mA [kΩ]	
Accuracy to DIN 16086, max. setting	$\leq \pm 0.5\%$ FS typ. $\leq \pm 1.0\%$ FS max.	
Accuracy at minimum setting (B.F.S.L.)	$\leq \pm 0.25\%$ FS typ. $\leq \pm 0.5\%$ FS max.	
Temperature compensation	$\leq \pm 0.02\%$ FS / °C typ.	
Zero point	$\leq \pm 0.03\%$ FS / °C max.	
Temperature compensation	$\leq \pm 0.02\%$ FS / °C typ.	
Over range	$\leq \pm 0.03\%$ FS / °C max.	
Non-linearity at max. setting to DIN 16086	$\leq \pm 0.5\%$ FS max.	
Hysteresis	$\leq \pm 0.4\%$ FS max.	
Repeatability	$\leq \pm 0.1\%$ FS	
Rise time	≤ 1.5 ms	
Long term drift	$\leq \pm 0.3\%$ FS typ. / year	
Environmental conditions		
Compensated temperature range	-20 .. +85 °C	
Operating temperature range	-20 .. +60 °C	
Storage temperature range	-40 .. +100 °C	
Fluid temperature range ²⁾	-40 .. +60 °C / -20 .. +60 °C	
CE - mark	EN 61000-6-1 / 2 / 3 / 4 EN 60079-0 / 11 / 26 / 31 EN 50303	
Vibration resistance to DIN EN 60068-2-6 at 10 .. 500 Hz	≤ 20 g	
Protection class to IEC 60529	IP 65 (for male EN 175301-803(DIN 43650)) IP 67 (for M12x1 male, when an IP 67 female connector is used)	
Relevant data for Ex applications		
Supply voltage	U _i = 12 .. 28 V	Ex nA, ta, tb, tc 12 .. 28 V
Max. input current	i _i = 100 mA	
Max. input power	P _i = 1 W	max. power consumption ≤ 1 W
Connection capacitance of the sensor	C _i = ≤ 22 nF	
Inductance of the sensor	L _i = 0 mH	
Insulation voltage ³⁾	50 V AC, with integrated overvoltage protection EN 61000-6-2	
Other data		
Residual ripple of supply voltage	$\leq 5\%$	
Life expectancy	> 10 million cycles 0 .. 100% FS	
Weight	~ 180 g	

Note: Reverse polarity protection of the supply voltage, excess voltage, override and short circuit protection are provided.

FS (Full Scale) = relative to complete measuring range

B.F.S.L. = Best Fit Straight Line

¹⁾ Other seal materials on request

²⁾ -20 °C with FPM seal, -40 °C on request

³⁾ 500 V AC on request

Areas of application:

Code Model code	1		9	A	C	
Protection type	I M1 Ex ia I Ma	II 1G Ex ia IIC T6 Ga II 1/2G Ex ia IIC T6 Ga/Gb II 1D Ex ia IIIC T85 °C Da	II 2G Ex ia IIC T6 Gb	II 3G Ex nA IIC T6 Gc	II 1D Ex ta IIIC T80 °C T ₅₀₀ T90 °C Da II 2D Ex tb IIIC T80 °C Db	II 3G Ex ic IIC T6 Gc II 3D Ex ic IIIC T80 °C Dc
Certificate	KEMA 05ATEX1016 X / KEMA 05ATEX1021					
Zones / Categories	Group I Category M1 Mining Protection class: intrinsically safe ia with barrier	Group II, III Category 1G, 1/2G, 1D Gases/conductive dust Protection class: intrinsically safe ia with barrier	Group II Category 2G Gases Protection class: intrinsically safe ia with barrier	Group II Category 3G Gases Protection class: Non-sparking nA	Group III Category 1D, 2D Conductive dust Protection class: Dustproof enclosure	Group II, III Category 3G, 3D Gases/conductive dust Protection class: Intrinsically safe ic with barrier
Electrical Connection (see model code)	4, 5, 6	4, 5, 6	4, 5, 6	6	6	4,5,6

Devices in ignition protection class "Dustproof enclosure" for the protection types II 1D Ex ta IIIC T80/90/100 °C Da T₅₀₀ T90/T100/T110 °C Da, II 2D Ex tb IIIC T80/90/100 °C Db and II 3D Ex tc IIIC T80/90/100 °C Dc are available with flying leads on request.

Devices in the ignition protection class "Non-sparking" for the protection type II 3G Ex nA IIC T6, T5, T4 Gc are available with flying leads on request.

Pin connections:

EN 175301-803 (DIN 43650)

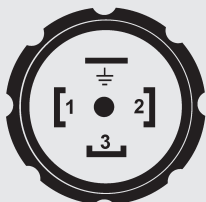

Pin	HDA 43Z5-A
1	Signal +
2	Signal -
3	n.c.
⊥	Housing

M12x1, 4 pole

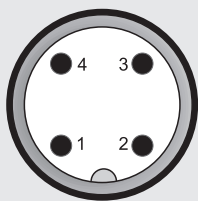

Pin	HDA 43Z6-A
1	Signal +
2	n.c.
3	Signal -
4	n.c.

Model code:

HDA 4 3 Z X - A - XXXX - XXX - A N X - XXX

Mechanical process connection

Z = Flush membrane

Electrical connection

- 5 = Male 3 pole + PE,
EN 175301-803 (DIN 43650)
(female connector supplied)
- 6 = Male M12x1, 4 pole
(female connector not supplied)

Signal

A = 4 .. 20 mA, 2 conductor

Pressure ranges in bar

0001(-1..1); 0009(-1..9); 01.0; 02.5; 04.0;
06.0; 0010; 0016; 0025; 0040

Mechanical connection

- G01 = G1/2 A, DIN 3852
- G02 = G1/2 with additional front O-ring seal
- G04 = G1/4 with additional front O-ring seal

Approval

A = ATEX

Insulation voltage

N = 50 V AC

Protection types and applications (code)

- 1 = I M1 Ex ia I Ma
II 1G Ex ia IIC T6 Ga
II 1/2G Ex ia IIC T6 Ga/Gb
II 2G Ex ia IIC T6 Gb
II 1D Ex ia IIIC T85 °C Da
- 9 = II 3G Ex nA IIC T6 Gc (only in conjunction with electr. connection "6")*
- A = II 1D Ex ta IIIC T80 °C T₅₀₀ T90 °C Da (only in conjunction with electr. connection "6")*
II 2D Ex tb IIIC T80 °C Db
- C = II 3G Ex ic IIC T6 Gc
II 3D Ex ic IIIC T80 °C Dc

Modification number

000 = Standard

Notes:

* For design and electrical connection see Dimensions

Accessories:

Appropriate accessories, such as electrical female connectors, can be found in the Accessories brochure.

Dimensions:

Protection types and applications (code): 1, C

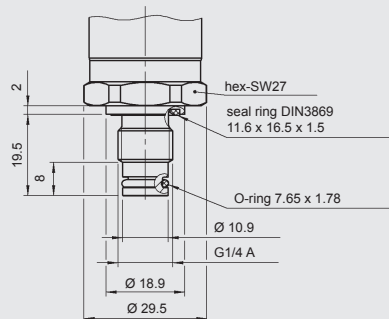
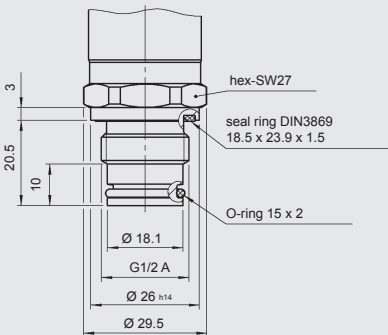
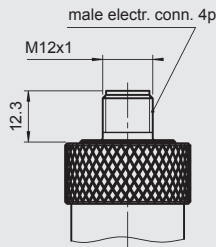
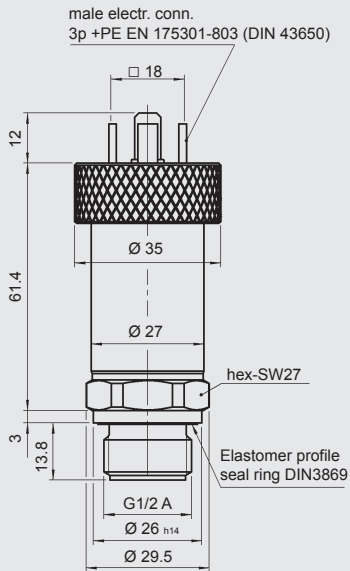
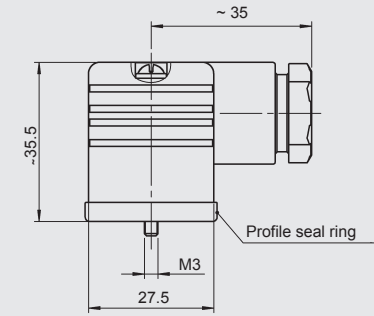

Protection types and applications (code): 9, A

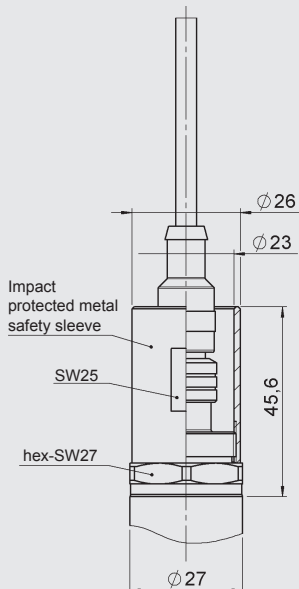

The impact protected metal safety sleeve is included. A straight female connector is required for electrical connection. e.g. female connector M12x1, 4 pole, straight, with 3m shielded cable: ZBE 06S-03, Part. No. 6098243

Note:

The information in this brochure relates to the operating conditions and applications described. For applications and operating conditions not described, please contact the relevant technical department. Subject to technical modifications.

