



Angle Sensor

HAT 1400

CAN interface

Two-chamber design

Magnetic

Absolute

Singleturn, 14 bit



Features

- Contactless, magnetic measurement method
- Robust design
- IP 6K9K (two-chamber design)

Description

HAT 1400 is an absolute measuring singleturn angle sensor.

Due to its two-chamber design, the electronic unit is completely encapsulated which means it meets IP 6K9K if the electrical connection is carried out accordingly.

The measured value is digitized and made available to the CAN field bus system via the CANopen protocol or the J1939 protocol. The instrument parameters can be viewed and configured by the user using standard CAN software.

Application fields

Thanks to its non-contact magnetic measuring method and its robust design, the HAT 1400 is ideally suited for the measurement of the rotational angle in mobile machines.

The sensor is therefore suitable for a large variety of applications in the automobile industry and in mobile work machines.

Especially for the use in public traffic vehicles, HAT 1400 is approved for road vehicles according ECE type approval via the E13 approval.

Technical Data

Input data	
Measurement range	0 .. 360 °
Direction of rotation	No orientation restrictions
Max. axial load	60 N
Max. radial load	100 N
Material, housing	Stainless steel
Material, shaft	Stainless steel
Output data	
Output signal	CANopen protocol or SAE J1939 protocol, depending on version
Resolution	14 bit
Accuracy (at room temperature)	± 0.1° typ. ± 0.2° max.
Accuracy (over the temperature range)	± 0.05 ° / 10 K typ. ± 0.1° / 10 K max.
Repeatability	≤ ± 0.05 °
Angle increase	cw / ccw (factory-set)
Environmental conditions	
Operating temperature range	-40 .. +85 °C
Storage temperature range	-40 .. +85 °C
CE mark	EN 61000-6-1 / -2 / -3 / -4
E ³ mark	E13*10R00*10R05*14136*00
Vibration resistance acc. to DIN EN 60068-2-6: 2008	7.5 mm (5 Hz ≤ f < 8.2 Hz) 2 g (8.2 Hz ≤ f < 2000 Hz)
Shock resistance acc. to DIN EN 60068-2-27: 2010	20 g (11 ms in 3 axes)
Protection type to DIN EN 60529 ¹⁾	IP 67, IP 6K9K (electronics)
Protocol data for CANopen	
Communication profile	CI A DS 301 V4.2.0
NMT-Services	CI A DSP 302 V4.1
Layer setting services and protocol	CI A DSP 305 V2.2
Encoder Device Profile	CI A DS 406 V3.2
Baud rates	10 kbit/s to 1 Mbit/s according to DS305 V2.2
Transmission services	
- PDO	Measured value as 32 bit
- Transfer	synchronous, asynchronous, cyclical
Node ID/ Baud rate	Adjustable via LSS
Protocol data for SAE J1939	
Data Link Layer	SAE J1939-21
Network Layer	SAE J1939-31
Network Management	SAE J1939-81
Default Settings	Baud rate: 250 kbit/s; CAN Data Source Address: 1
Other data	
Supply voltage	9 .. 36 V DC
Residual ripple of supply voltage	≤ 5 %
Power consumption	< 1.4 W
Weight	~ 186 g

Note: Reverse polarity protection of the supply voltage, overvoltage, override and short circuit protection are provided.

¹⁾ With mating connector of corresponding protection type fitted

Dimensions

Mechanical connection: solid shaft

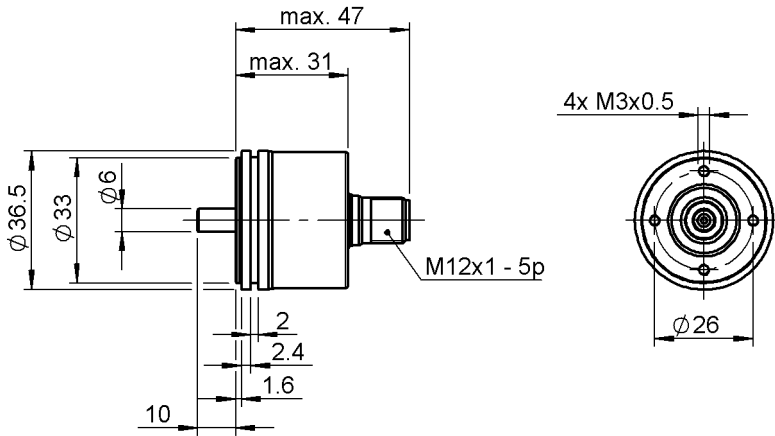

Mechanical connection: D-shape:

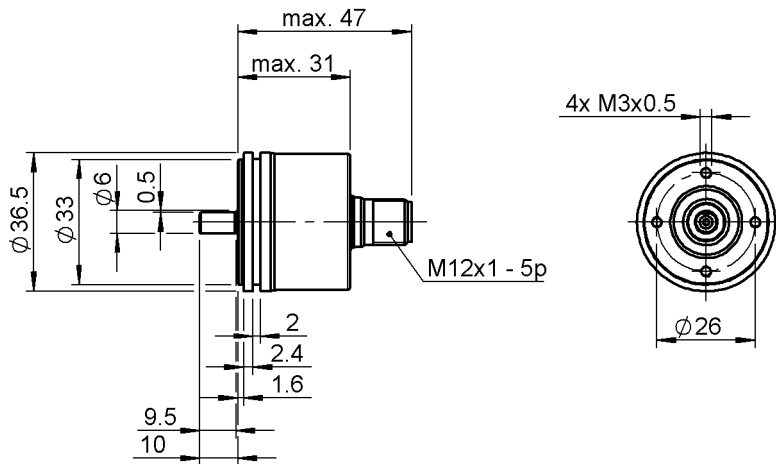

Pin connections

M12x1, 5 pole	Pin	Output signal: F1X	
		Signal	Description
	1	CAN_SHLD	Shield/housing
	2	CAN_V+	External supply +
	3	CAN_GND	Ground / 0 V / V -
	4	CAN_H	Bus line dominant high
	5	CAN_L	Bus line dominant low

Model code

HAT 1 436 - F1X - XXXX - P01 - XXXX - M01 - 000

Resolution

4 = 14 Bit

Housing diameter

36 = 36 mm

Output signal

F11 = CANopen

F12 = SAE J1939

Measuring range in ° and rotational direction ¹⁾

360R = 360°, clockwise rotation

360L = 360°, anti-clockwise

Electrical connection

P01 = Installation plug M12x1; 5 pole, axial

Mechanical connection

V106 = Solid shaft, length 10 mm, diameter 6 mm

D106 = D-shape, length 10 mm, diameter 6 mm

Fixing type

M01 = Synchro flange with 4 threaded bores

Modification number

000 = Standard

Accessories:

Appropriate accessories, such as mating connectors, can be found in the Accessories brochure.

Note:

Special models on request

¹⁾ Viewed from the side of the shaft

Note

The information in this brochure relates to the operating conditions and applications described.

For applications or operating conditions not described, please contact the relevant technical department.

Subject to technical modifications.

HYDAC ELECTRONIC GMBH

Hauptstraße 27

66128 Saarbrücken/Germany

Telephone +49 (0)6897 509-01

Fax +49 (0)6897 509-1726

E-mail: electronic@hydac.com

Internet: www.hydac.com